1.1 GENERAL

The Toshiba T2000SX is one of the lightest and most advanced portable computers available offering high technology, high speed, excellent legibility, IBM PC/AT compatibility, and battery operation.

The T2000SX is so small it defines a new class of portables called notebook computers.

The T2000SX system unit consists of the following features:

- The central processing unit (CPU) is the 80386SX-16 32-bit microprocessor, operated at 16MHz.
- The standard random access memory (RAM) capacity is 1Mbyte with the ability to insert 1-, 2-, 4- or 8-Mbyte expansion memory card; thus, the system can have up to 9Mbyte of RAM.
- The 80387SX-16 numeric data processor (NDP) can be connected.
- The liquid crystal display (LCD) supports 640 x 480 pixels with video graphics array (VGA) compatibility and 16-level gray scale.
- The display controller supports high resolution graphics subsystem (HRGS), including the functions of VGA.
- The 3.5-inch floppy disk drive (FDD) supports two memory formats:
 - 1.44Mbyte double-sided, high-density, double-track (2HD)
 - 720Kbyte double-sided, double-density, double-track (2DD)
- A 2.5-inch hard disk drive (HDD) with 20Mbyte or 40Mbyte capacity.
- The keyboard is a 86/88-key keyboard with the keys of a subset of the industry standard 101/102-key keyboard.
- The universal auto-sensing AC adapter is used for world-wide usage.
- The T2000SX has a built-in modem slot for a T1200 or T1000SE style modem.
- Connecting ports for optional equipment are provided. A parallel port, serial port, RGB port, numeric keypad port, and expansion bus connector are all provided for.
- The resume feature keeps the data and system configuration when the T2000SX power is off.
- The real time clock (RTC) continuously keeps the date and time even when the T2000SX power is off.

The T2000SX Personal Computer is shown in Figure 1-1, and the configuration of the T2000SX's system unit is shown in Figure 1-2.



Figure 1-1 T2000SX system unit

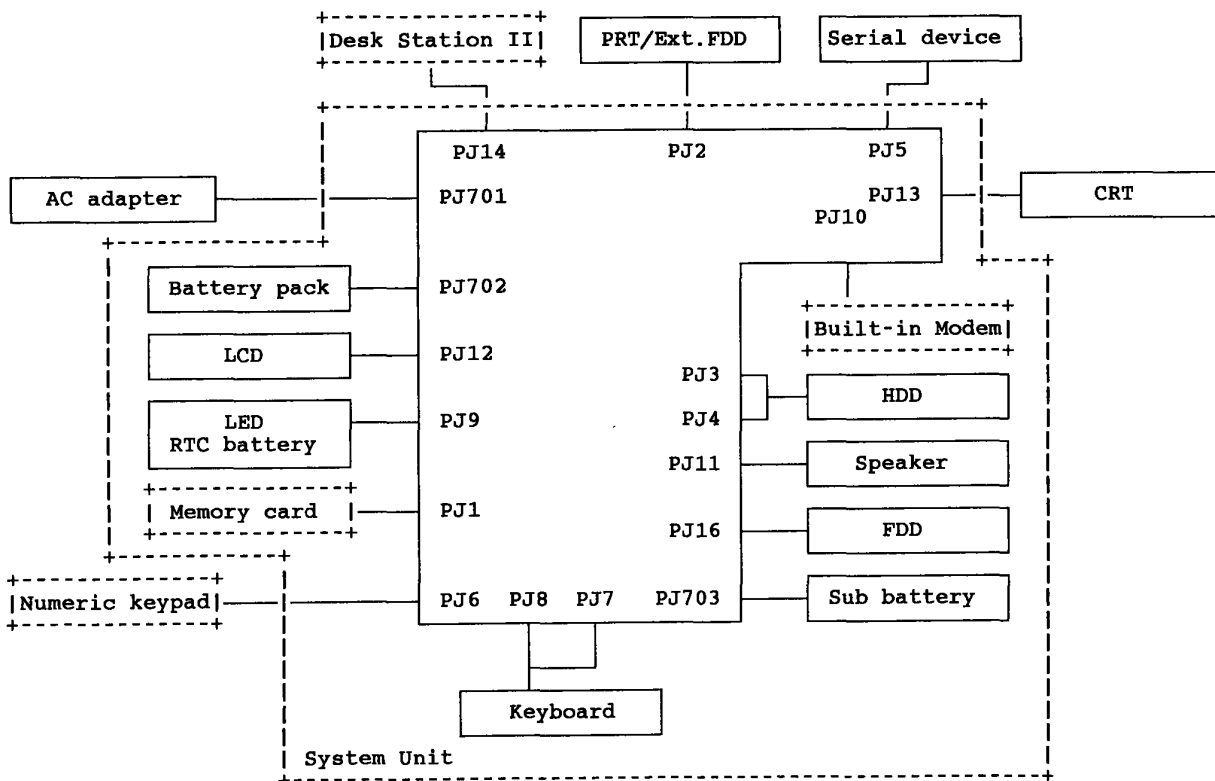

Figure 1-2 System unit configuration

1.2 SYSTEM UNIT

Figure 1-3 shows the T2000SX's system block diagram.

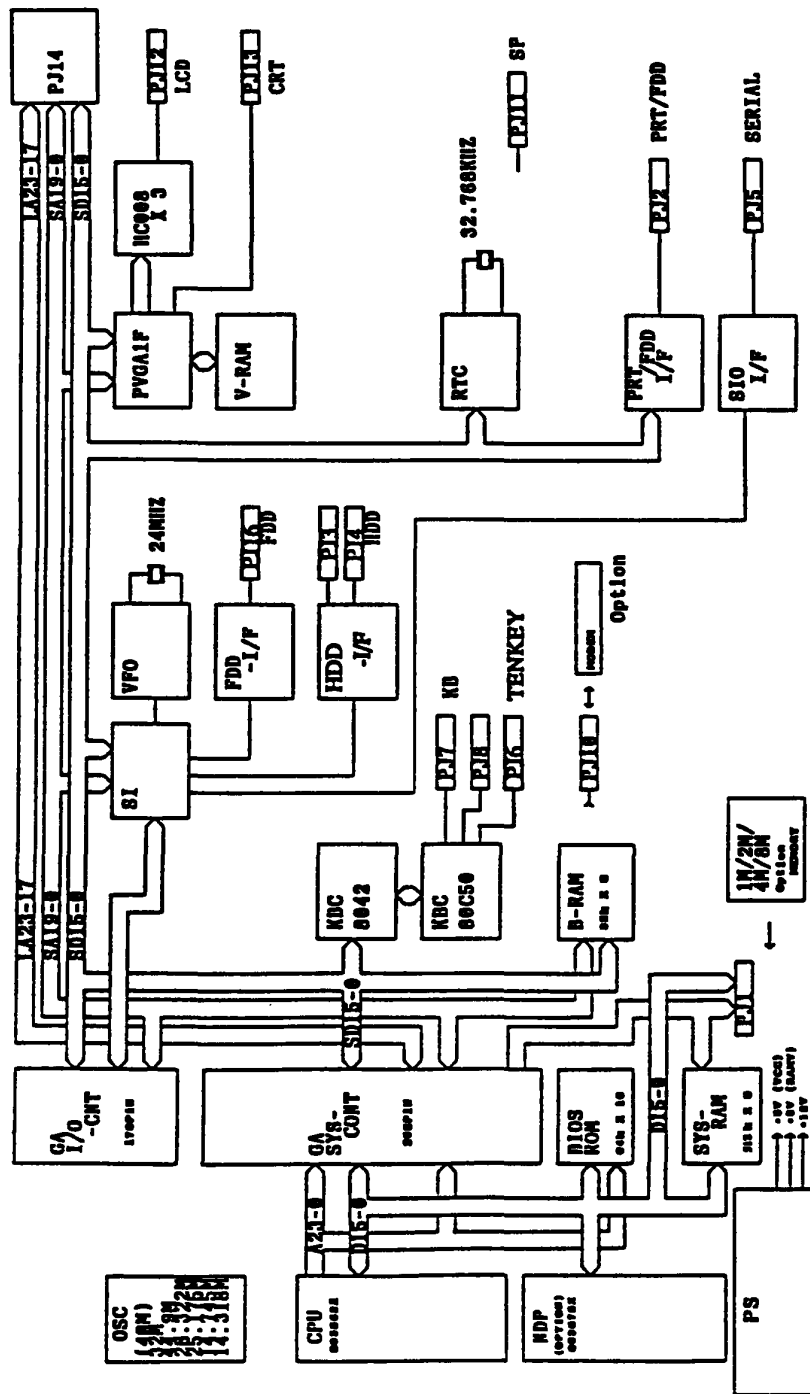

Figure 1-3 Block diagram

The system board in the T2000SX is composed of the following major components:

- Central processing unit (CPU): 80386SX-16

The CPU is a 32-bit microprocessor operating at a 16MHz or 8MHz clock speed.

- Numeric data processor (NDP) socket for the 80387SX-16 (option)

- Super integration (SI): T9778

- The SI stores the following components:

- Direct memory access controller (DMAC): 82C37A x 2
- Programmable interrupt controller (PIC): 82C59A x 2
- Programmable interval timer (PIT): 82C54
- Floppy disk controller (FDC): TC8565
- Serial input/output controller (SIO): TC8570

- Variable frequency oscillator (VFO): L8568AM

The VFO chip is used for FDD control logic.

- Real time clock (RTC): 146818AF

The RTC has memory in the chip which keeps the date, time, and system configuration with an RTC battery.

- Keyboard interrupt controller (KBIC): 80C42

- Keyboard scan controller (KBSC): 80C50

- Power supply controller (PSC): U47C660

- Memories:

Standard RAM: 1Mbyte

Backup RAM: 32Kbyte

BIOS ROM: 128Kbyte (96Kbyte are used)

This ROM contains the initial reliability test (IRT), system basic input/output system (system BIOS), and VGA BIOS.

Video RAM: 256Kbyte

Optional memory card: The system can have up to a total of 9Mbyte by installing the optional memory card.

- Gate arrays:

System control gate array : GA-SYS CNT (208-pin)

I/O control gate array: GA-IO CNT (176-pin)

VGA flat panel display controller: PVGA1F (132-pin)

- **Oscillators (OSC):**

14.7456MHz OSC (X1) is used for the SIO.

14.31818MHz OSC (X2) is used for the KBC.

44.9MHz OSC (X3), 28.322MHz OSC (X5), and 25.175MHz OSC (X6) are used for the video.

32.0MHz OSC (X4) is used for the CPU.

24MHz OSC (X7) is used for the VFO.

32.768KHz OSC (X8) is used for the RTC.

500KHz OSC (X701) is used for the PSC.

The locations of these OSCs are shown in Appendix A.

1.3 3.5-INCH FLOPPY DISK DRIVE

The 3.5-inch floppy disk drive (FDD) is a high performance, reliable, and thin drive that supports 720Kbyte (formatted) 2DD and 1.44Mbyte (formatted) 3.5-inch floppy diskettes.

The FDD is shown in Figure 1-4 and its specifications are described in Table 1-1.

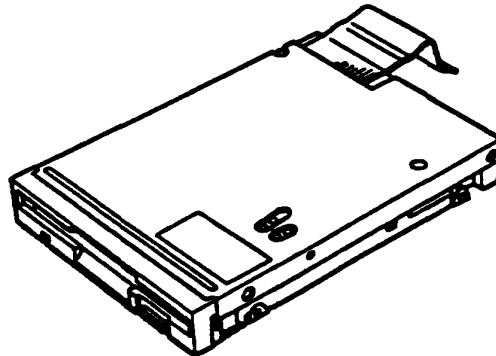

Figure 1-4 3.5-inch FDD

Table 1-1 3.5-inch FDD specifications

Item	2-Mbyte mode	1-Mbyte mode
Storage capacity (Kbyte)		
Unformatted	2,000	1,000
Formatted	1,440	720
Number of heads	2	2
Number of cylinders	80	80
Access time (ms)		
Track to track	3	3
Average	181	181
Head settling time	15	15
Recording track density (bpi)	135	135
Data transfer rate (Kbps)	500	250
Rotation speed (rpm)	300	300
Recording method	MFM (modified frequency modulation)	

1.4 2.5-INCH HARD DISK DRIVE

The 20Mbyte or 40Mbyte (formatted) hard disk drive (HDD) is a random access storage device. It is equipped with a non-removal 2.5-inch magnetic disk and mini-Winchester type magnetic heads.

The HDD is shown in Figure 1-5 and its specifications are described in Table 1-2.

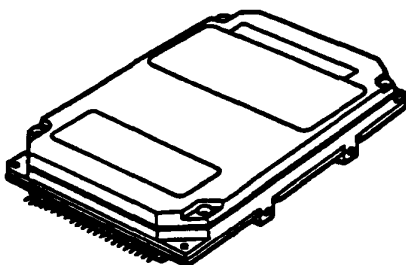

Figure 1-5 2.5-inch HDD

Table 1-2 2.5-inch HDD specifications

Item	20-Mbyte	40-Mbyte	
	CP-2024	CP-2044	JD-E2850P
Storage capacity (Mbytes) Formatted	21.4	42.5	42.52
Number of disks	1	2	2
Data heads	2	4	3
Data surfaces	2	4	3
Track per surface	653	552	791(+2)
Tracks per drive	1,306	2,208	2,373(+6)
Sectors per track	32(+1)	38(+1)	35(+1)
Bytes per sector	512	512	512
Access time (ms)			
Track to track	5	5	9
Average	23	19	25
Maximum	40	40	47
Rotation speed (rpm)	3,444	3,486	3,109
Data transfer rate (bps)			
To/from media	10 M	12 M	10 M
Interleave	1:1	1:1	1:1
Recording method	2-7 RLL	2-7 RLL/ 1-7 RLL	2-7 RLL

1.5 KEYBOARD

The 86- (USA) or 88- (European) keyboard is mounted on the system unit. The keyboard is connected to the keyboard controller on the system board through an 8-pin flat cable and 12-pin flat cable. The keyboard is shown in Figure 1-6.

Optional keyboard configurations are illustrated in Appendix E.

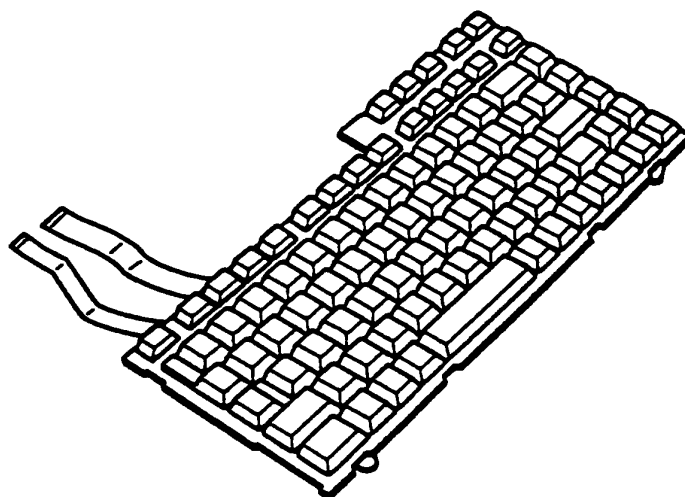

Figure 1-6 Keyboard

1.4 2.5-INCH HARD DISK DRIVE

The 20Mbyte or 40Mbyte (formatted) hard disk drive (HDD) is a random access storage device. It is equipped with a non-removal 2.5-inch magnetic disk and mini-Winchester type magnetic heads.

The HDD is shown in Figure 1-5 and its specifications are described in Table 1-2.

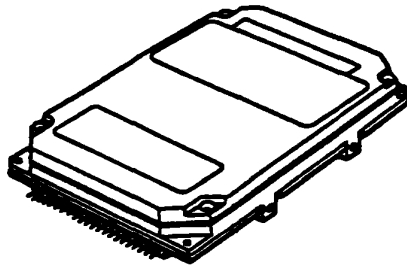

Figure 1-5 2.5-inch HDD

Table 1-2 2.5-inch HDD specifications

Item	20-Mbyte	40-Mbyte	
	CP-2024	CP-2044	JD-E2850P
Storage capacity (Mbytes) Formatted	21.4	42.5	42.52
Number of disks	1	2	2
Data heads	2	4	3
Data surfaces	2	4	3
Track per surface	653	552	791(+2)
Tracks per drive	1,306	2,208	2,373(+6)
Sectors per track	32(+1)	38(+1)	35(+1)
Bytes per sector	512	512	512
Access time (ms)			
Track to track	5	5	9
Average	23	19	25
Maximum	40	40	47
Rotation speed (rpm)	3,444	3,486	3,109
Data transfer rate (bps) To/from media	10 M	12 M	10 M
Interleave	1:1	1:1	1:1
Recording method	2-7 RLL	2-7 RLL/ 1-7 RLL	2-7 RLL

(2) FL inverter board

The FL inverter board supplies the high frequency current needed to illuminate the FL.

FL inverter specifications are described in Table 1-4.

Table 1-4 FL inverter specifications

	Item	Specifications
Input	Voltage (V)	12 - 24
	Power (W)	3.6 (Max.)
Output	Voltage (V)	800 (Min.)
	Current (mA)	5.5
	Frequency (KHz)	39
	Bounds of current (mA)	3.25 - 6.5

2.1 GENERAL

The problem isolation procedures described in Part 2 are used to isolate defective field replaceable units (FRUs). The FRUs covered are:

1. Power supply unit
2. System board (PCB FT2SYx)
3. FDD
3. HDD
4. Keyboard
5. Display

Test program operations are described in Part 3 and detailed replacement procedures are described in Part 4.

The following items are necessary for implementing the problem isolation procedures:

1. T2000SX Diagnostics Disk
2. Phillips head screwdriver
3. MS-DOS system disk
4. 2DD or 2HD formatted work disk (for FDD testing)
5. Cleaning disk kit (for FDD testing)
6. Printer port LED
7. RS-232-C wraparound connector
8. Printer wraparound connector
9. Multimeter

The problem isolation flowchart described in Section 2.2 may be used to determine which isolation procedures are necessary to isolate a T2000SX problem.

2.2 PROBLEM ISOLATION FLOWCHART

The flowchart in Figure 2-1 is used as a guide for determining which FRU is defective. Please confirm the following before performing the flowchart procedures.

1. Disconnect all optional equipment.
2. Remove any diskette in the FDD.

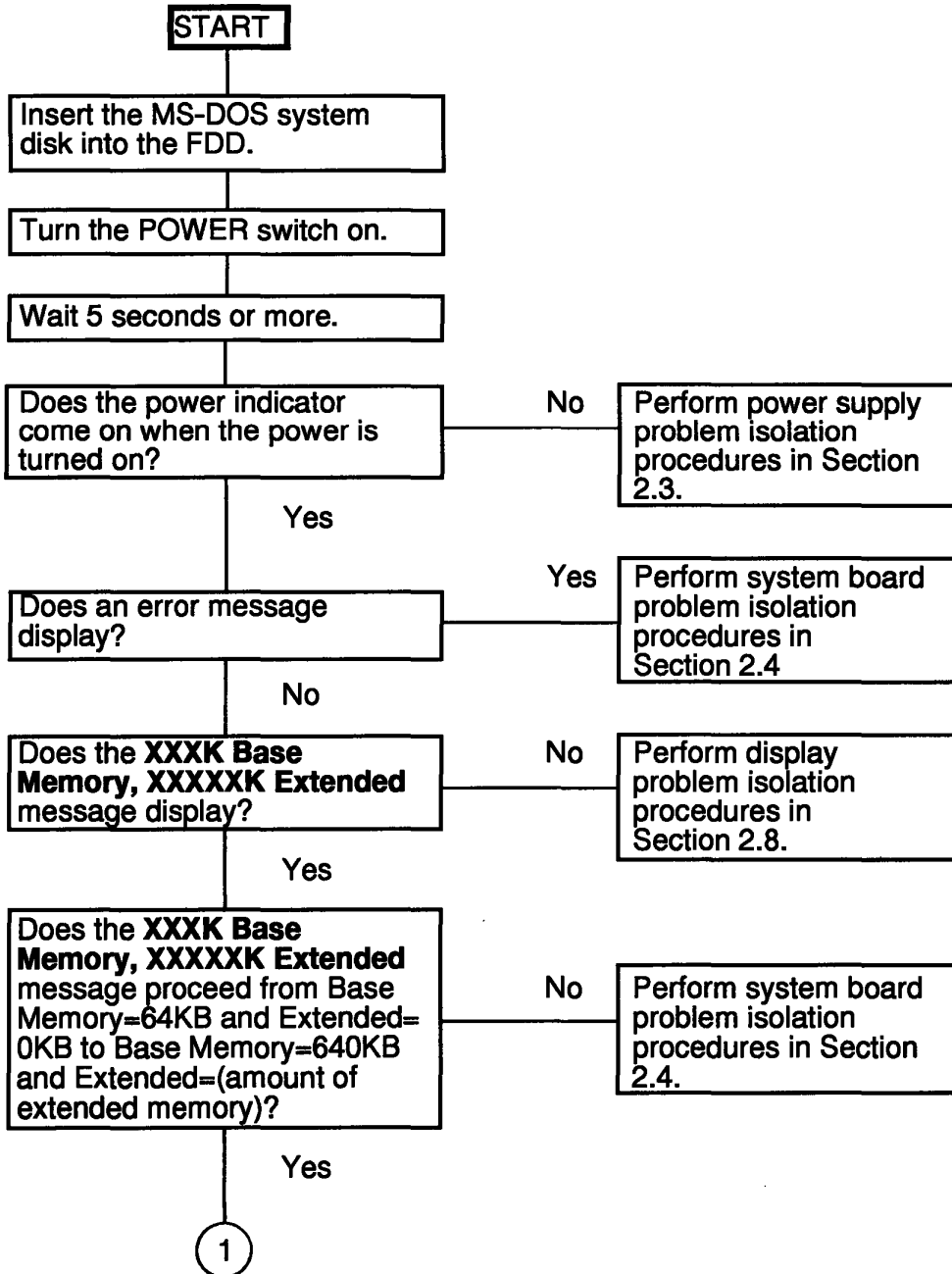

Figure 2-1 Problem isolation flowchart

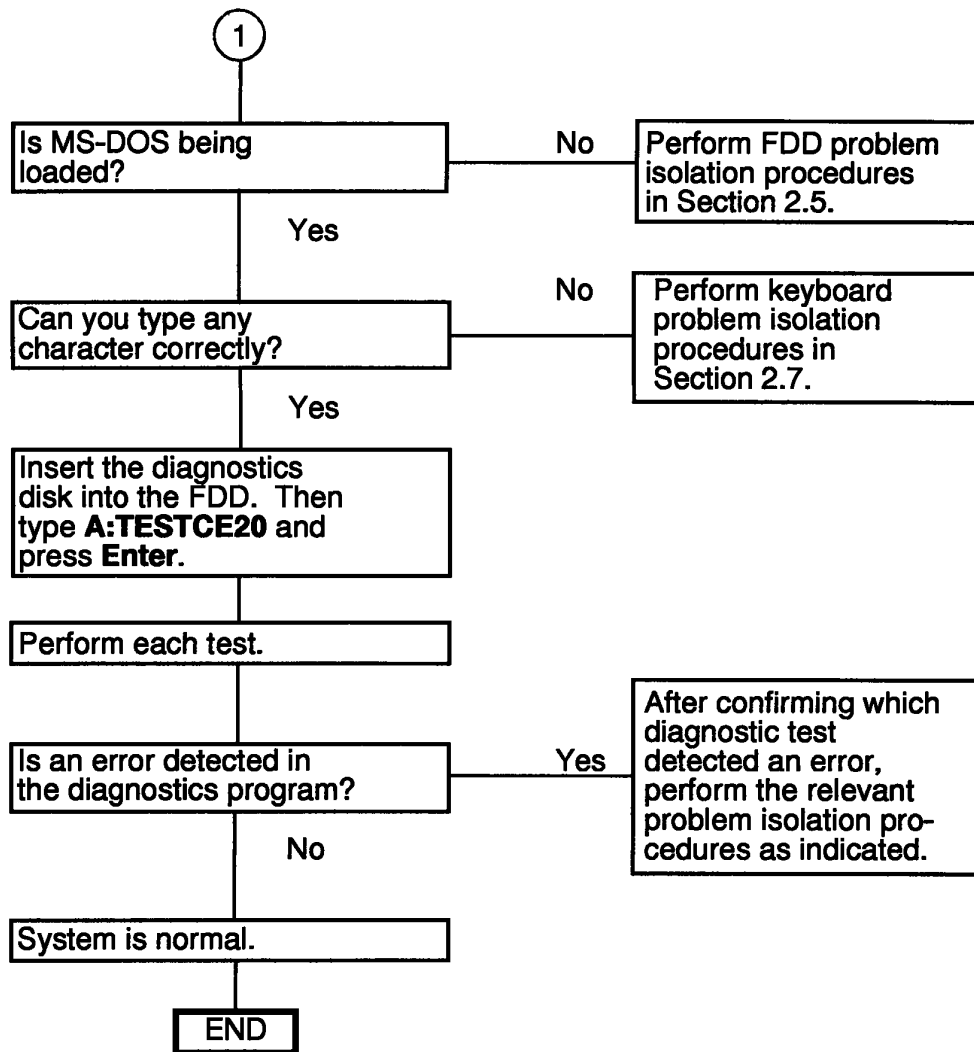

Figure 2-1 Problem isolation flowchart (continued)

If the diagnostics program cannot detect any errors, it may be an intermittent problem. The running test should be executed several times to isolate the problem.

After confirming which diagnostic test detected an error, perform the relevant problem isolation procedures as follows.

1. If an error is detected on the system test, memory test, display test, ASYNC test, printer test, or real timer test, perform the system board isolation procedures in Section 2.4.
2. If an error is detected on the keyboard test, perform the keyboard problem isolation procedures in Section 2.7.
3. If an error is detected on the floppy disk test, perform the FDD problem isolation procedures in Section 2.5.
4. If an error is detected on the hard disk test, perform the HDD problem isolation procedures in Section 2.6.

2.3 POWER SUPPLY PROBLEM ISOLATION PROCEDURES

This section describes how to determine if the power supply is defective. Start with PROCEDURE 1 and continue with the other procedures as instructed. The procedures described in this section are:

PROCEDURE 1: Indicator Check

PROCEDURE 2: Connector and Cable Check

PROCEDURE 3 Replacement Check

PROCEDURE 1

Indicator Check

1. The indicator labeled **DC IN** lights red if power is supplied from the AC adapter when you connect the AC adapter to the T2000SX and a wall outlet. If the AC adapter's output voltage is abnormal or the power supply malfunctions, this indicator blinks red or does not glow.
 - (1) If the **DC IN** indicator blinks red, see Check 1.
 - (2) If the **DC IN** indicator does not glow, see Check 2.

Check 1 If a power supply problem occurs, the **DC IN** indicator will blink repeatedly with a 4-bit status that varies dependent upon the problem.

The **DC IN** indicator is off for two seconds, then it lights for either $\frac{1}{2}$ second (indicating a binary 0) or one full second (indicating a binary 1). There is a one-second interval between bits, with bit 0 (zero) or the least significant bit first and ending with bit 3 (three) or the most significant bit.

For example, the status is 5h (0101).

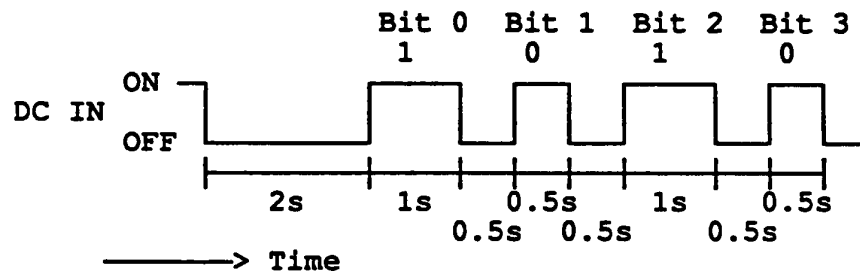

The status and its meaning are described in Table 2-1.

However, when the **DC IN** indicator blinks at random, the AC adapter or charging circuit may be damaged. In this case, replace the AC adapter with a new one. If the problem still exists, perform PROCEDURE 3.

Table 2-1 Power supply error status

Status	Meaning
1h	Over voltage of AC adapter output voltage. (More than +18V±5%)
2h	Abnormal temperature in the system. (Less than -20°C or more than 70°C.)
3h	Abnormal charging (The system cannot stop charging.)
4h	Over current of charging current.
5h	Abnormal charging voltage.
6h	Abnormal battery voltage.
7h	Abnormal VCC (+5V) voltage.
8h	Abnormal RAMV (+5V for DRAM) voltage.
9h	VEE (-9V) is shorted.
Ah	VDD (+12V) is shorted.
Bh	VDSP (+12V to +18V for FL) is shorted.
Ch	Turned off the Desk Station II before turned off the T2000SX.
Dh	Battery terminal is shorted.
Eh	Under voltage of AC adapter output voltage. (Less than +18V±5%)
Fh	Under current of charging current.

Check 2 When the **DC IN** indicator does not glow, the cause is one of the following:

1. The AC adapter is damaged; therefore, it does not supply power.
2. The charge (+18V) switching signal is not supplied correctly.
3. The AC adapter detecting circuit is damaged.

Note: In any of the above cases, replace the AC adapter with a new one.

4. The fuse (F701) on the system board is blown.

Note: In this case, replace the system board with a new one.

If the problem still exists, perform PROCEDURE 3.

2. The indicator labeled **Battery** lights yellow (while the system is charging the battery) or lights green (when the battery pack is fully charged) if power is supplied from the AC adapter when you connect the battery pack to the system.

Note: However, the system automatically stops charging the battery when the battery pack overheats.

If only the battery pack is connected to the system, this indicator does not light (indicating the battery pack is in use) or blinks red (indicating the battery is low). If the battery pack is completely discharged, this indicator does not light.

- (1) If the battery indicator blinks or does not glow when you connect the AC adapter to the system, see Check 3.
 - (2) If the battery indicator blinks or does not glow when you disconnect the AC adapter to the system, see Check 6. Also, check the power output circuits to the system.
- Check 3 Make sure the battery pack is correctly connected to the system. If the problem still exists, perform Check 4.
- Check 4 Connect the AC adapter to the system and wait 30 minutes or so. If the problem still exists, perform Check 5.
- Check 5 Replace the battery pack with a recharged battery pack. If the problem still exists, perform PROCEDURE 2. Also, check the battery charge circuits.
- Check 6 Make sure the battery pack is correctly connected to the system. If the problem still exists, perform Check 7.
- Check 7 Replace the battery pack with a known good one. If the problem still exists, perform PROCEDURE 2.

PROCEDURE 2

Connector and Cable Check

The battery pack is connected to the system board through the battery cable. They may be disconnected or damaged. Disassemble the system unit to checking the cables. Disassembly procedures are described in Part 4.

Check 1 Check that the following cable is correctly connected to the system board.

Terminal —————> System board PJ702

If this cable is disconnected, connect them and restart the system. If the problem still exists, perform Check 2.

Check 2 Recheck the above cable using multimeter. If this cable looks damaged, replace the terminal assembly and restart the system. If the problem still exists, perform **PROCEDURE 3**.

PROCEDURE 3

Replacement Check

In this system unit, the power supply circuits are located on the system board. There is a connector from PJ704 to PJ705 that supplies voltage to the system. The LED board (PCB FT2LE_x) connects to PJ9 on the system board. Either of these boards may be damaged. Perform Checks 1 and 2 to replace them. Replacement procedures are described in Part 4.

- Check 1 Replace the LED board with a new one and restart the system. If the problem still exists, perform Check 2.

- Check 2 Replace the system board with a new one. If the problem still exists, other units may be damaged.

2.4 SYSTEM BOARD PROBLEM ISOLATION PROCEDURES

This section describes how to determine if the system board is defective. Start with **PROCEDURE 1** and continue with the other procedures as instructed. The procedures described in this section are:

PROCEDURE 1: Message and Beep Sound Check

PROCEDURE 2: Printer Port LED Check

PROCEDURE 3: Test Program Check

PROCEDURE 1

Message and Beep Sound Check

After the power is turned on, the system performs the initial reliability test (IRT) which is a program stored in BIOS ROM on the system board. The IRT tests and initializes each IC on the system board.

If an error message appears on the screen, perform Check 1, and if nothing is displayed on the screen, perform PROCEDURE 2.

Check 1 If the following error message appears on the screen briefly, the **PRT/FDD** port is assigned as **FDD-A** and an external FDD is not attached to the **PRT/FDD** port. Assign the **PRT/FDD** port as **FDD-B** or **Printer**, or attach an external FDD. Then reboot the system.

If another error message appears, perform Check 2.

***** FDD A is not installed *****

Check 2 If the following error message appears on the screen, press the **F1** key. Then execute the setup operation. Detailed setup operation is described in Part 3.

This program confirms the current system configuration and the configuration stored to RTC memory. If they are different, the following message will appear.

If another error message appears, perform Check 3.

***** Error in CMOS. Bad battery *****
Check system. Then press [F1] key.

***** Error in CMOS. Bad check sum *****
Check system. Then press [F1] key.

***** Error in CMOS. Bad memory configuration *****
Check system. Then press [F1] key.

***** Error in CMOS. Bad time function *****
Check system. Then press [F1] key.

Check 3 If the following message appears, and the status of the printer port LED is **F4h** to **F6h**, replace the system board. Otherwise, press any key. At this time the resumed data will be erased.

If another error message appears, perform Check 4.

**WARNING: RESUME FAILURE.
PRESS ANY KEY TO CONTINUE.**

**WARNING: DATA IN HARD RAM WAS LOST
YOU MUST FORMAT HARD RAM BEFORE USE
PRESS ANY KEY TO CONTINUE**

Check 4 The IRT program tests the system board. If an error occurs in the IRT program, the error message appears on the screen and beep sounds are generated.

If the following message appears, replace the system board.

If the following error message does not appear, perform Check 5.

ERROR INTERRUPT CONTROLLER #1

ERROR INTERRUPT CONTROLLER #2

MEMORY VERIFY ERROR AT XXXX:XXXX FOUND XXXX EXPECTED XXXX

ERROR INTERRUPTS AND STUCK NMI

ERROR PROTECT MODE

ERROR PROCESSOR EXCEPTIONAL INTERRUPTS

Check 4 If the following message is displayed on the screen, go to the HDD problem isolation procedures in Section 2.6.

If the following error message does not appear and the beep sounds are not heard, perform PROCEDURE 2.

ERROR ENCOUNTERED INITIALIZING HARD DISK DRIVE

ERROR INITIALIZING HARD DISK CONTROLLER

PROCEDURE 2

Printer Port LED Check

The printer port LED displays the IRT program status and error status as a hexadecimal value after turning on the system.

1. Connect the printer port LED to the printer port.
2. After turning the system on, read the LED status from left to right as you are facing the rear of the system.
3. If the final LED status is FFh, perform PROCEDURE 3. If the final LED status matches one of the error status codes in Table 2-2, replace the system board.

Table 2-2 Normal status and error status of the printer port LED

Normal status	Error status	Meaning	Process
00h	C0h	CPU self-test	Halt
01h	81h	CPU test 1 (flag test)	Halt
02h	82h	KBIC IBF/OBF test, video initialization	Halt
03h	83h	KBIC IBF test (0AAh command)	Halt
04h	84h	KBIC OBF test (55h check)	Halt
05h		Reserved	
06h		LSI initialization (DMA, PIT, PIC, RTC)	Continue
07h	87h	CPU test 2 (registers)	Halt
08h		RTC initialization (register B)	Continue
09h	89h	ROM checksum test (64KB)	Halt
0Ah	8Ah	Video initialization	Halt
0Bh		Reserved	
0Ch		Reserved	
0Dh	8Dh	PIT channel 2 test and its initialization	Halt
0Eh		Reserved	
0Fh	8Fh	CMOS RAM test	Halt
10h	90h	DMA channel 0 test	Halt
11h	91h	DMA channel 1 test	Halt
12h	92h	DMA page register test	Halt
13h	93h	KBSC test and its initialization	Halt
14h	94h	Memory refresh test	Halt
	A7h	Backup RAM test	Halt
	14h	Protect mode test	Halt
15h	95h	First 64KB RAM test	Halt
16h		Interrupt vector setup	Continue
17h	97h	Video option test	Halt
18h	98h	V-RAM test	Halt
19h	99h	PIC channel 1 test	3 beeps continue
1Ah	9Ah	PIC channel 2 test	3 beeps continue

Table 2-2 Normal status and error status of the printer port LED (continued)

Normal status	Error status	Meaning	Process
1Bh	9Bh	CMOS battery test	1 beep key wait
1Ch		Reserved	Continue
1Dh	9Dh	Setup RAM size from CMOS (413h)	Continue
1Eh	9Eh	Size conventional RAM	Continue
1Fh	9Fh	Conventional RAM test	3 beeps continue
20h	A0h	PIC ch1/ch2 test	Continue
21h	A1h	NMI check	Continue
22h	A2h	Interrupt process test (INT8)	3 beeps continue
23h	A3h	Protect mode test	3 beeps continue
24h	A4h	Size extended RAM	Continue
25h	A5h	Conventional & extended RAM test	3 beeps continue
26h	A6h	Protect mode exception test	3 beeps continue

Note: If the error occurs on the 19h to 24h normal status, the system does not halt. Error messages remain on the screen, and when the IRT program is finished, these error messages are erased.

The table below lists the resume errors and the associated error status codes.

Status	Explanation
F1h	An FDD was running when the power was turned off. Power was turned off while the IRT was running. The hardware reset switch was pressed. An external display card was attached while the power was turned off. An external expansion memory card was attached when the power was turned off.
F2h	An external display card was attached while the power was turned off.
F3h	An internal display card was changed while the power was turned off.
F4h	Backup RAM has been corrupted. The backup RAM checksum, system RAM checksum, V-RAM checksum, or expansion memory checksum in backup RAM has been corrupted.
F5h	System RAM has been corrupted.
F6h	V-RAM has been corrupted.
F7h	Internal expansion memory has been corrupted.

PROCEDURE 3

Test Program Check

The test program which is stored in the T2000SX Diagnostics Disk has several programs for testing the system board. Perform the following tests. Detailed operation is described in Part 3.

- System test
- Memory test
- Display test
- Printer test
- ASYNC test
- Real timer test

If an error is detected during the above tests, replace the system board. If the problem still exists, another unit may be defective. Continue troubleshooting the system unit.

2.5 FLOPPY DISK DRIVE PROBLEM ISOLATION PROCEDURES

This section describes how to determine if the floppy disk drive is defective. Start with PROCEDURE 1 and continue with the other procedures as instructed. The procedures described in this section are:

- PROCEDURE 1: Message Check
- PROCEDURE 2: Format Check
- PROCEDURE 3: Test Program Check
- PROCEDURE 4: Connector Check

PROCEDURE 1

Message Check

Prepare an MS-DOS system disk.

Turn the power switch on after the MS-DOS system disk is inserted to the FDD. If loading starts normally, perform PROCEDURE 2.

If loading starts abnormally, the following message may appear on the screen. If the following message appears, perform PROCEDURE 4.

**Place system disk in drive.
Press any key when ready.**

**Non-System disk or disk error
Replace and press any key when ready**

PROCEDURE 2

Format Check

Prepare a new floppy disk by formatting it using the MS-DOS FORMAT command.

If the floppy disk does not format correctly, perform the following checks.

- Check 1** Check that the FDD indicator lights. If it does not light, perform PROCEDURE 4. If it lights, perform Check 2.
- Check 2** Check that the MS-DOS FORMAT command was used correctly.
When the media type is 2DD, use the FORMAT/3 command.
When the media type is 2HD, use the FORMAT command.
If the FORMAT command is used correctly, perform Check 3.
If the FORMAT command was not used correctly, try again. If the problem still exists, perform Check 3.
- Check 3** Clean the read/write head using the 3.5-inch FDD cleaning kit. If the problem still exists, perform PROCEDURE 3.

PROCEDURE 3

Test Program Check

The FDD test program is stored in the T2000SX Diagnostics Disk. After loading MS-DOS, run the diagnostic program. Detailed operation is described in Part 3.

Prepare a formatted floppy disk, then perform the FDD test. The error code and status are described in Table 2-3.

If an error occurs, perform Check 1.

Table 2-3 FDD error code and status

Code	Status
01h	Bad command
02h	Address mark not found
03h	Write protected
04h	Record not found
06h	Media removed on dual attach card
08h	DMA overrun error
09h	DMA boundary error
10h	CRC error
20h	FDC error
40h	Seek error
60h	FDD not drive
80h	Time out error (Not ready)
EEh	Write buffer error

Check 1 If the **Write protected** message appears, remove the write protect tab. If any other error message appears, perform Check 2.

Check 2 Check that the floppy disk is formatted correctly. If it is correct, perform PROCEDURE 4.

PROCEDURE 4

Connector Check

The FDD is connected to the system unit by the FDD cable. This cable may be disconnected from the system unit. Disassemble the system unit and check the FDD cable. Disassembly procedures are described in Part 4.

Check 1 Check that the following cable is correctly connected to the system board.

FDD cable —————> System board PJ16

If this cable is disconnected, connect it to the system unit and perform PROCEDURE 2 and 3. If the problem still exists, perform Check 2.

Check 2 The FDD may be defective. Replace it with a new FDD, then perform PROCEDURES 2 and 3. If the problem still exists, perform Check 3.

Check 3 The system board may be defective. Replace it with a new system board.

2.6 HARD DISK DRIVE PROBLEM ISOLATION PROCEDURES

This section describes how to determine if the hard disk drive is defective. Start with PROCEDURE 1 and continue with the other procedures as instructed. The procedures described in this section are:

- PROCEDURE 1: Message Check
- PROCEDURE 2: Logical Format Check
- PROCEDURE 3: Test Program Check
- PROCEDURE 4: Connector Check

CAUTION: *The contents of the hard disk will be erased by performing the HDD problem isolation procedures. Before continuing, transfer the contents of the hard disk to floppy disks. This can be done with the MS-DOS BACKUP command. (See the MS-DOS manual for details.)*

PROCEDURE 1

Message Check

When the power switch is turned on, the following message may appear on the screen. If the following message appears, perform PROCEDURE 4.

If the following message does not appear, perform PROCEDURE 2.

ERROR ENCOUNTERED INITIALIZING HARD DISK DRIVE

ERROR INITIALIZING HARD DISK CONTROLLER

PROCEDURE 2

Logical Format Check

Using the MS-DOS system disk, make a partition of the hard disk by using the FDISK command. Then format the hard disk by using the FORMAT command. At this time type /s after FORMAT to transfer the system program.

If normal operation is restored, the HDD is normal. If normal operation is not restored, perform PROCEDURE 3.

PROCEDURE 3

Test Program Check

The HDD test program is stored in the T2000SX Diagnostics Disk. Perform all the HDD tests. Detailed operation is described in Part 3.

If an error is detected during the HDD test, an error code and status will be displayed; perform PROCEDURE 4. The error code and status are described in Table 2-4. If no error is generated, the HDD is normal.

Table 2-4 HDD error code and status

Code	Status
01h	Bad command error
02h	Bad address mark
04h	Record not found
05h	HDC not reset
07h	Drive not initialize
09h	DMA boundary error
0Ah	Bad sector error
0Bh	Bad track error
10h	ECC error
11h	ECC recover enable
20h	HDC error
40h	Seek error
80h	Time out error
AAh	Drive not ready
BBh	Undefined
CCh	Write fault
E0h	Status error
F0h	Not sense error (HW. code=FF)

PROCEDURE 4

Connector Check

The HDD is connected to the system board by a flex cable on the HDD board (PCB FT2HDx, HDD flex cable). Disassemble the system unit and check the HDD flex cable. Detailed procedures are described in Part 4.

Check 1 Check that the following cable and connectors are properly connected.

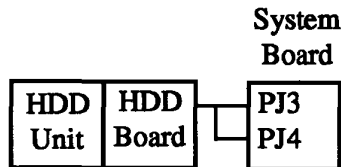

If any component is disconnected, connect it and perform PROCEDURE 1. If the problem still exists, perform Check 2.

Check 2 The HDD may be damaged. Replace the HDD unit with a new one. If the error still occurs, perform Check 3.

Check 3 The system board may be damaged. Replace the system board with a new one. If the error still occurs, perform Check 4.

Check 4 The HDD board may be damaged. Replace the HDD board with a new one.

2.7 KEYBOARD PROBLEM ISOLATION PROCEDURES

This section describes how to determine if the keyboard is defective. Start with PROCEDURE 1 and continue with the other procedures as instructed. The procedures described in this section are:

PROCEDURE 1: Test Program Check

PROCEDURE 2: Connector Check

PROCEDURE 1

Test Program Check

The keyboard test program is stored in the T2000SX Diagnostics Disk. Perform the test program. Detailed operation is described in Part 3.

If an error occurs, perform PROCEDURE 2. If an error does not occur, the keyboard is normal.

PROCEDURE 2

Connector Check

The keyboard is connected to the system board by an 8-pin flat cable and a 12-pin flat cable. Disassemble the system unit and check these keyboard cables. Detailed procedures are described in Part 4.

Check 1 Check that the following cables are connected to the system board.

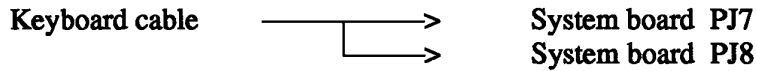

If these cables are not connected, connect them and perform PROCEDURE 1. If the problem still exists, perform Check 2.

Check 2 The keyboard or keyboard cables may be damaged. Replace the keyboard with a new one, then perform PROCEDURE 1. If the problem still exists, perform Check 3.

Check 3 The keyboard controller on the system board may be damaged. Replace the system board with a new one.

2.8 DISPLAY PROBLEM ISOLATION PROCEDURES

This section describes how to determine if the display is defective. Start with **PROCEDURE 1** and continue with the other procedures as instructed. The procedures described in this section are:

PROCEDURE 1: **Brightness and Contrast Volume Check**

PROCEDURE 2: **Test Program Check**

PROCEDURE 3: **Connector Check**

PROCEDURE 4: **Replacement Check**

PROCEDURE 1

Brightness and Contrast Volume Check

The system has brightness and contrast dials on the right side of the display unit. Use these two dials to tune up the display screen to your satisfaction.

If the brightness does not change, perform PROCEDURE 3.

If the contrast does not change, perform PROCEDURE 3.

If the brightness and contrast do change, perform PROCEDURE 2.

PROCEDURE 2

Test Program Check

Using the T2000SX Diagnostics Disk, perform the display test. The display test checks the display controller on the system board.

If an error is detected, perform PROCEDURE 3.

If an error is not detected, the display is normal.

PROCEDURE 3

Connector Check

The display unit has an LCD module, FL (fluorescent lamp) and FL inverter. The LCD module and FL inverter are connected to the system board with the LCD cable. The LED board (PCB FT2LEx) is connected directly to the system board. Either or both of these cables may be disconnected from the system board.

Disassemble the display unit and check these connectors. Detailed procedures are described in Part 4.

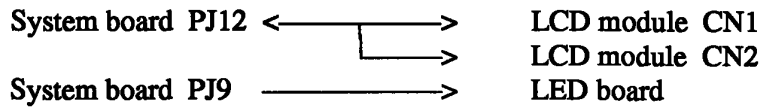

If these connectors are not connected, connect them and perform PROCEDURES 1 and 2. If the problem still exists, perform PROCEDURE 4.

PROCEDURE 4

Replacement Check

In this system unit, the FL inverter, LCD module and system board are connected with the display circuits. Any of these may be damaged. Perform Checks 1 through 3. Detailed procedures are described in Part 4.

- Check 1** Replace the FL inverter with a new one and recheck the display. If the problem still exists, perform Check 2.

- Check 2** Replace the LCD module with a new one and recheck the display. If the problem still exists, perform Check 3.

- Check 3** The system board may be damaged. Replace the system board with a new one and recheck the display. If the problem still exists, perform Check 4.

- Check 4** The LED board may be damaged. Replace the LED board with a new one.

This page intentionally left blank

3.1 GENERAL

This part explains the test and diagnostics programs which check the functions of all the hardware modules of the T2000SX.

The T2000SX ASP diagnostics are composed of 18 programs grouped into two modules: the service program module (DIAGNOSTICS MENU) and test program module (DIAGNOSTIC TEST MENU).

The service program module is composed of 8 tasks:

1. DIAGNOSTIC TEST
2. HARD DISK FORMAT
3. HEAD CLEANING
4. LOG UTILITIES
5. RUNNING TEST
6. FDD UTILITIES
7. SYSTEM CONFIGURATION
8. SETUP

The test program module is composed of 10 tests:

1. SYSTEM TEST
2. MEMORY TEST
3. KEYBOARD TEST
4. DISPLAY TEST
5. FLOPPY DISK TEST
6. PRINTER TEST
7. ASYNC TEST
8. HARD DISK TEST
9. REAL TIMER TEST
10. NDP TEST

The following items are necessary for carrying out the test and diagnostic programs.

1. T2000SX Diagnostics Disk
2. Formatted work disk (For FDD test)
3. Cleaning disk kit (For head cleaning)
4. Printer wraparound connector (For printer wraparound test)
5. RS-232-C wraparound connector (For ASYNC wraparound test)

Service personnel can use these programs to isolate problems by selecting the appropriate program and operation procedures described in Section 3.2.

3.2 OPERATIONS

1. After loading MS-DOS, insert the Diagnostics Disk in the floppy disk drive.
2. Type in **A:TESTCE20** and press **Enter**.
3. The following display will appear:

TOSHIBA personal computer T2000SX DIAGNOSTICS
version x.xx (c) copyright TOSHIBA Corp. 1990

DIAGNOSTICS MENU :

- 1 - DIAGNOSTIC TEST
- 2 - HARD DISK FORMAT
- 3 -
- 4 - HEAD CLEANING
- 5 - LOG UTILITIES
- 6 - RUNNING TEST
- 7 - FDD UTILITIES
- 8 - SYSTEM CONFIGURATION
- 9 - EXIT TO MS-DOS
- 0 - SETUP

PRESS [1] - [9] KEY

The service program tasks are explained in Sections 3.16 through 3.22.

NOTE: To stop execution of the test program:
(1) During keyboard operation, press **Ctrl + C**.
(2) While running a test program, press **Ctrl + Break**.

4. Type in 1 and press Enter. The following display will appear:

TOSHIBA personal computer T2000SX DIAGNOSTICS
version x.xx (c) copyright TOSHIBA Corp. 1990

DIAGNOSTIC TEST MENU :

- 1 - SYSTEM TEST
- 2 - MEMORY TEST
- 3 - KEYBOARD TEST
- 4 - DISPLAY TEST
- 5 - FLOPPY DISK TEST
- 6 - PRINTER TEST
- 7 - ASYNC TEST
- 8 - HARD DISK TEST
- 9 - REAL TIMER TEST
- 10 - NDP TEST
- 88 - FDD & HDD ERROR RETRY COUNT SET
- 99 - EXIT TO DIAGNOSTICS MENU

PRESS [1] - [9] KEY

Numbers 1 through 10 are diagnostic tests. These tests are explained in Sections 3.4 through 3.13.

Number 88 is for setting the floppy disk drive and hard disk drive error retry count.

Number 99 is for returning to the DIAGNOSTICS MENU.

When selecting the floppy disk test or hard disk test, special sub-messages will appear as described in Sections 3.8. and 3.11.

5. After typing in a test number (1 through 10) from the DIAGNOSTIC TEST MENU, press Enter. A test-specific display will appear. For example, the following screen shows the system test, which appears when you type 1 and press Enter .

```
SYSTEM TEST                XXXXXXXX                T2000SX DIAGNOSTIC TEST Vx.xx
                                [Ctrl]+[Break] ; test end
                                [Ctrl]+[C]   ; key stop

SUB-TEST : XX
PASS COUNT: XXXXX   ERROR COUNT: XXXXX
WRITE DATA: XX     READ DATA : XX
ADDRESS : XXXXXX   STATUS : XXX

SUB-TEST MENU :

01 - ROM checksum
02 - HW status
99 - Exit to DIAGNOSTIC TEST MENU

SELECT SUB-TEST NUMBER ?
```

6. Select a subtest. See Table 3-1 for a list of the valid subtest numbers. Type the subtest number, then press **Enter**. The following message will appear:

TEST LOOP (1:YES/2:NO) ?

If you select YES (by typing in 1 and then pressing **Enter**):

Each time a test cycle ends, it increments the pass counter by one and repeats the test cycle.

If you select NO (by typing in 2 and pressing **Enter**):

At the end of a test cycle, the test execution is terminated and you exit to the subtest menu.

7. Type in 1 or 2, then press **Enter**. The following message will appear:

ERROR STOP (1:YES/2:NO) ?

If you select YES (by typing in 1 and pressing **Enter**):

When an error occurs, the error status is displayed. Execution of the test program stops and the operation guide is displayed on the right side of the display screen.

If you select NO (by typing in 2 and pressing **Enter**):

When an error occurs, the error status is displayed. The error counter increases by one and you continue with the subtest.

8. Type in 1 or 2, then press **Enter** and the test program will run. Each subtest is described in Table 3-1 of Section 3.3.

9. When an error occurs during the test program, the following message (operation guide) will appear (if you answered YES for the ERROR STOP question):

```
ERROR STATUS NAME      [[ HALT OPERATION ]]  
                        1 : Test End  
                        2 : Continue  
                        3 : Retry
```

- 1: Terminates the test program execution and exits to the subtest menu.
- 2: Continues the test.
- 3: Retries the test.

The error code and error status names are described in Table 3-3 of Section 3.14.

3.3 SUBTEST NAMES

Table 3-1 lists the subtest of each test program.

Table 3-1 Subtest names

No.	Test name	Subtest No.	Subtest item
1	SYSTEM	01	ROM checksum
		02	HW status
2	MEMORY	01	RAM constant data
		02	RAM address pattern data
		03	RAM refresh
		04	Protected mode
		05	Memory module
		06	Backup memory
		07	Hard-RAM
3	KEYBOARD	01	Pressed key display(86/88)
		02	Pressed key code display
4	DISPLAY	01	VRAM read/write
		02	Character attributes
		03	Character set
		04	80 * 25 Character display
		05	320*200 Graphics display
		06	640*200 Graphics display
		07	640*400 Graphics display
		08	Display page
		09	"H" pattern display
		10	LED / DAC pallet
5	FDD	01	Sequential read
		02	Sequential read/write
		03	Random address/data
		04	Write specified address
		05	Read specified address
6	PRINTER	01	Ripple pattern
		02	Function
		03	Wrap around
7	ASYNC	01	Wrap around (board)
		02	Board(#1) <=> board#2
		03	Point to point (send)
		04	Point to point (receive)
		05	Card modem loopback (1200BPS)
		06	Interrupt test
8	HDD	01	Sequential read
		02	Address uniqueness
		03	Random address/data
		04	Cross talk & peak shift
		05	Write/read/compare(CE)
		06	Write specified address
		07	Read specified address
		08	ECC circuit
		09	Sequential write
		10	W-R-C specified address
9	REAL TIMER	01	Real time
		02	Backup memory
		03	Real time carry
10	NDP	01	NDP test

3.4 SYSTEM TEST

Subtest 01 ROM checksum

This test performs the IPL ROM checksum test on the system board.
(Test extent : F0000h - FFFFFh 64KB)

Subtest 02 HW status

This test reads the system hardware status, then displays the status as shown below.
Press **Enter** to return to the system test's SUB-TEST MENU. Table 3-2 describes the hardware status bits.

```
H/W status = 76543210  
              10001000
```

```
Bit7 - =  
Bit6 - CPU clock = 16MHZ  
Bit5 - Notch signal = 2HD  
Bit4 - FDD type = 2MB  
Bit3 - =  
Bit2 - Drive A/B = Ext. = B  
Bit1 - External FDD = OFF  
Bit0 - Internal FDD = 2HD
```

Table 3-2 Hardware status bit

Bit	H/W status	1	0
7	Reserved		
6	CPU clock speed	8 MHz	16 MHz
5	Media type	2DD	2HD
4	FDD type	1 MB	2 MB
3	Reserved		
2	Drive A/B	B	A
1	External FDD	ON	OFF
0	Internal FDD	2DD	2HD

3.5 MEMORY TEST

Subtest 01 RAM constant data

This subtest writes constant data to conventional memory (640KB), then reads and compares it with the original data.

The constant data is FFFFh, AAAAh, 5555h, 0101h, and 0000h.

Subtest 02 RAM address pattern data

This subtest writes address pattern data created by XORing (Exclusive-ORing) the address segment and address offset to memory (640KB), then reads and compares it with the original data.

Subtest 03 RAM refresh

This subtest writes 256-byte constant data to conventional memory (640KB), then reads and compares it with the original data.

The constant data is AAAAh and 5555h.

There is a delay between the write and the read operations.

Subtest 04 Protected mode

This subtest writes constant data and address data to extended memory (addressed 100000h to the max.), then reads and compares it with the original data.

Subtest 05 Memory module

The same test as described for subtest 04 is done for the memory module (optional memory card). Memory module capacity is 1-, 2-, 4-, and 8-Mbyte.

After selecting the subtest, the following message will appear:

Extended memory size (1:1MB,2:2MB,3:4MB,4:8MB) ?

When the memory card is 1Mbyte, select option 1.

When the memory card is 2Mbyte, select option 2.

When the memory card is 4Mbyte, select option 3.

When the memory card is 8Mbyte, select option 4.

Subtest 06 Backup memory

This subtest writes constant data (FFh, AAh, and 00h) and address pattern data created by XORing high/low of the offset address to memory (addressed E8000h to EFFFFh), then reads and compares it with the original data.

Subtest 07 Hard-RAM

This subtest writes constant data to memory (addressed E0000h to E7FFFh), then reads and compares it with the original data.

The constant data is FFFFh, AAAAh, and 5555h.

3.6 KEYBOARD TEST

Subtest 01 Pressed key display

Note: Make sure the Num Lock key is off. If this key is on, the test cannot be carried out.

When the keyboard layout (as shown below) is drawn on the display, press any key and check that the corresponding key on the screen is changed to the character “*”.

When a key is held down, the display will blink indicating the auto-repeat function.

KEYBOARD TEST IN PROGRESS 301000

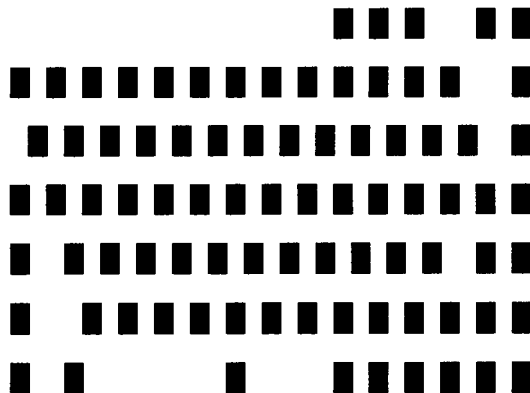

[Print:Alt+SysReq , Pause:Ctrl+Break]
IF TEST OK, PRESS [DEL] THEN [ENTER] KEY

Subtest 02 Pressed key code display

When a key is pressed, its scan code, character code, and key top name are displayed on the screen in the format shown below.

The **Ins Lock**, **Caps Lock**, **Num Lock**, **Scroll Lock**, **Alt**, **Ctrl**, **Left Shift**, and **Right Shift** keys are displayed in reverse screen when pressed.

The scan codes, character codes, and key top names are described in Appendix E.

KEYBOARD TEST IN PROGRESS 302000

Scan code =
Character code =
Keytop =

Ins Lock Caps Lock Num Lock Scroll Lock
Alt Ctrl Left Shift Right Shift

PRESS [Enter] KEY

3.7 DISPLAY TEST

Subtest 01 VRAM read/write

This subtest writes constant data and address data to video RAM (256KB), then reads the data written and compares it with the original data.
The constant data is FFFFh, AAAAh, 5555h, and 0000h.

Subtest 02 Character attributes

This subtest checks:

- Normal Display
- Intensified Display
- Reverse Display
- Blinking Display

For color displays, all seven colors used (blue, green, cyan, red, magenta, yellow, and white) are displayed. After you press **Enter**, all sixteen background and foreground colors can then be checked for brightness.

The display below appears on the screen when this test is run.

CHARACTER ATTRIBUTES

NEXT LINE SHOWS NORMAL DISPLAY.

NNNNNNNNNNNNNNNNNNNNNNNNNNNNNNNNNNNN

NEXT LINE SHOWS INTENSIFIED DISPLAY.

IIIIIIIIIIIIIIIIIIIIIIIIIIIIIIIIIIII

NEXT LINE SHOWS REVERSE DISPLAY.

RRRRRRRRRRRRRRRRRRRRRRRRRRRRRRRRRR

NEXT LINE SHOWS BLINKING DISPLAY

BBBBBBBBBBBBBBBBBBBBBBBBBBBBBBBBBB

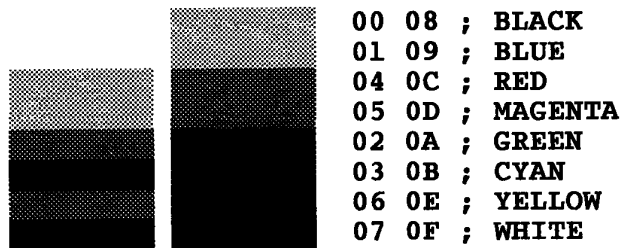

PRESS [ENTER] KEY

Subtest 04 80x25 Character display

In this subtest, the character string is displayed shifting one character line by line in the 80x25 and 80x30 character mode as shown below.

```

80*XX CHARACTER DISPLAY
01234567890123456789012345678901234567890123456789012345678901234567
! "$ % & ' ( ) * + , - . / 0 1 2 3 4 5 6 7 8 9 ; < = > ? @ A B C D E F G H I J K L M N O P Q R S T U V W X Y Z [ \ ] ^ _ ` a b c d e f g h i j k l m
! "$ % & ' ( ) * + , - . / 0 1 2 3 4 5 6 7 8 9 ; < = > ? @ A B C D E F G H I J K L M N O P Q R S T U V W X Y Z [ \ ] ^ _ ` a b c d e f g h i j k l m o
! "$ % & ' ( ) * + , - . / 0 1 2 3 4 5 6 7 8 9 ; < = > ? @ A B C D E F G H I J K L M N O P Q R S T U V W X Y Z [ \ ] ^ _ ` a b c d e f g h i j k l m n o
! "$ % & ' ( ) * + , - . / 0 1 2 3 4 5 6 7 8 9 ; < = > ? @ A B C D E F G H I J K L M N O P Q R S T U V W X Y Z [ \ ] ^ _ ` a b c d e f g h i j k l m n o p
! "$ % & ' ( ) * + , - . / 0 1 2 3 4 5 6 7 8 9 ; < = > ? @ A B C D E F G H I J K L M N O P Q R S T U V W X Y Z [ \ ] ^ _ ` a b c d e f g h i j k l m n o p q
! "$ % & ' ( ) * + , - . / 0 1 2 3 4 5 6 7 8 9 ; < = > ? @ A B C D E F G H I J K L M N O P Q R S T U V W X Y Z [ \ ] ^ _ ` a b c d e f g h i j k l m n o p q r
! "$ % & ' ( ) * + , - . / 0 1 2 3 4 5 6 7 8 9 ; < = > ? @ A B C D E F G H I J K L M N O P Q R S T U V W X Y Z [ \ ] ^ _ ` a b c d e f g h i j k l m n o p q r s
! "$ % & ' ( ) * + , - . / 0 1 2 3 4 5 6 7 8 9 ; < = > ? @ A B C D E F G H I J K L M N O P Q R S T U V W X Y Z [ \ ] ^ _ ` a b c d e f g h i j k l m n o p q r s t
! "$ % & ' ( ) * + , - . / 0 1 2 3 4 5 6 7 8 9 ; < = > ? @ A B C D E F G H I J K L M N O P Q R S T U V W X Y Z [ \ ] ^ _ ` a b c d e f g h i j k l m n o p q r s t u
! "$ % & ' ( ) * + , - . / 0 1 2 3 4 5 6 7 8 9 ; < = > ? @ A B C D E F G H I J K L M N O P Q R S T U V W X Y Z [ \ ] ^ _ ` a b c d e f g h i j k l m n o p q r s t u v
! "$ % & ' ( ) * + , - . / 0 1 2 3 4 5 6 7 8 9 ; < = > ? @ A B C D E F G H I J K L M N O P Q R S T U V W X Y Z [ \ ] ^ _ ` a b c d e f g h i j k l m n o p q r s t u v w
! "$ % & ' ( ) * + , - . / 0 1 2 3 4 5 6 7 8 9 ; < = > ? @ A B C D E F G H I J K L M N O P Q R S T U V W X Y Z [ \ ] ^ _ ` a b c d e f g h i j k l m n o p q r s t u v w x
! "$ % & ' ( ) * + , - . / 0 1 2 3 4 5 6 7 8 9 ; < = > ? @ A B C D E F G H I J K L M N O P Q R S T U V W X Y Z [ \ ] ^ _ ` a b c d e f g h i j k l m n o p q r s t u v w x y
! "$ % & ' ( ) * + , - . / 0 1 2 3 4 5 6 7 8 9 ; < = > ? @ A B C D E F G H I J K L M N O P Q R S T U V W X Y Z [ \ ] ^ _ ` a b c d e f g h i j k l m n o p q r s t u v w x y z
! "$ % & ' ( ) * + , - . / 0 1 2 3 4 5 6 7 8 9 ; < = > ? @ A B C D E F G H I J K L M N O P Q R S T U V W X Y Z [ \ ] ^ _ ` a b c d e f g h i j k l m n o p q r s t u v w x y z [
! "$ % & ' ( ) * + , - . / 0 1 2 3 4 5 6 7 8 9 ; < = > ? @ A B C D E F G H I J K L M N O P Q R S T U V W X Y Z [ \ ] ^ _ ` a b c d e f g h i j k l m n o p q r s t u v w x y z [ ]
! "$ % & ' ( ) * + , - . / 0 1 2 3 4 5 6 7 8 9 ; < = > ? @ A B C D E F G H I J K L M N O P Q R S T U V W X Y Z [ \ ] ^ _ ` a b c d e f g h i j k l m n o p q r s t u v w x y z [ ] -
! "$ % & ' ( ) * + , - . / 0 1 2 3 4 5 6 7 8 9 ; < = > ? @ A B C D E F G H I J K L M N O P Q R S T U V W X Y Z [ \ ] ^ _ ` a b c d e f g h i j k l m n o p q r s t u v w x y z [ ] - .
! "$ % & ' ( ) * + , - . / 0 1 2 3 4 5 6 7 8 9 ; < = > ? @ A B C D E F G H I J K L M N O P Q R S T U V W X Y Z [ \ ] ^ _ ` a b c d e f g h i j k l m n o p q r s t u v w x y z [ ] - . Ç
! "$ % & ' ( ) * + , - . / 0 1 2 3 4 5 6 7 8 9 ; < = > ? @ A B C D E F G H I J K L M N O P Q R S T U V W X Y Z [ \ ] ^ _ ` a b c d e f g h i j k l m n o p q r s t u v w x y z [ ] - . Çü
PRESS [ENTER] KEY
    
```

Subtest 05 320x200 Graphics display

This subtest displays three of the color sets for the color display in the 320x200 dots graphics mode (mode 4 and D) as shown below.

320*200 GRAPHICS DISPLAY
 COLOR SET X : [X]

GREEN	RED	YELLOW
CYAN	MAGENTA	WHITE

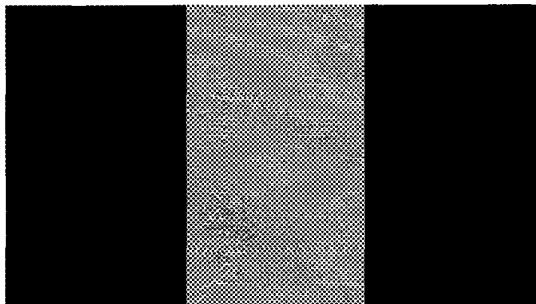

PRESS [ENTER] KEY

Subtest 06 640x200 Graphics display

This subtest displays the color blocks for the black and white display in the 640x200 dots graphics mode (mode 6 and E) as shown below.

640*200 GRAPHICS DISPLAY : [X]

**EVEN DOTS
DRIVEN**

**ODD DOTS
DRIVEN**

**ALL DOTS
DRIVEN**

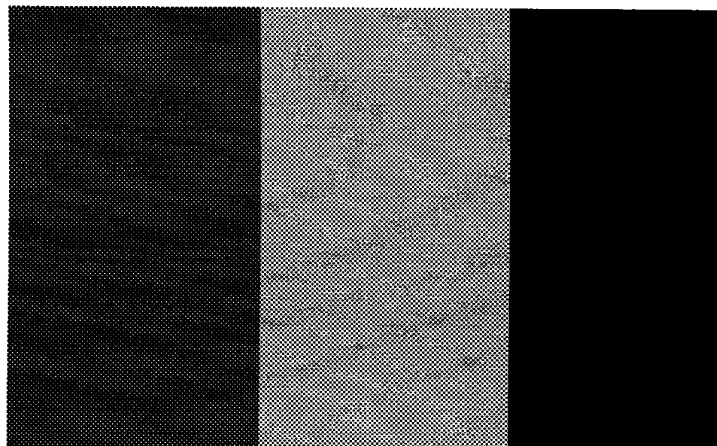

PRESS [ENTER] KEY

Subtest 07 640x400 Graphics display

This subtest displays the color blocks for the black and white display in the 640x350 and 640x480 pixels graphics mode (mode 10 and 12) as shown below.

640*400 GRAPHICS DISPLAY

**EVEN DOTS
DRIVEN**

**ODD DOTS
DRIVEN**

**ALL DOTS
DRIVEN**

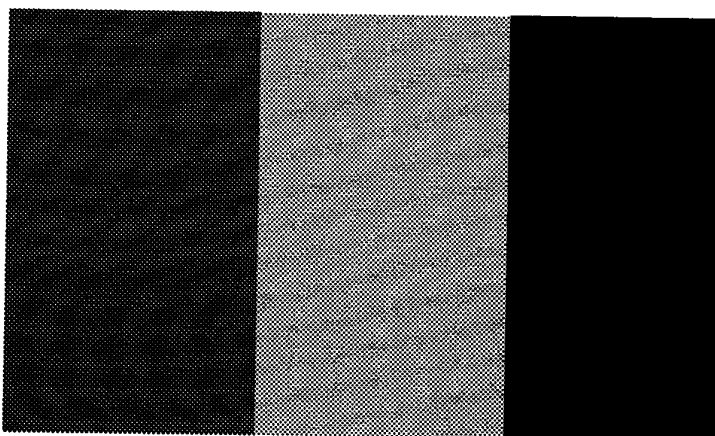

PRESS [ENTER] KEY

Subtest 08 Display page

This subtest confirms that the pages can be changed in order (page 0 to page 7) in the 40x25 character mode.

DISPLAY PAGE 0

```

0000000000000000000000000000000000000000000000000000000000000000
0
0
0
0
0
0
0
0
0
0
0
0
0
0
0
0
0
0000000000000000000000000000000000000000000000000000000000000000

```

Subtest 09 "H" pattern display

This subtest displays H characters on the entire screen, as shown below.

```

HHHHHHHHHHHHHHHHHHHHHHHHHHHHHHHHHHHHHHHHHHHHHHHHHHHHHHHHHHHHHHHHHHHH
HHHHHHHHHHHHHHHHHHHHHHHHHHHHHHHHHHHHHHHHHHHHHHHHHHHHHHHHHHHHHHHHHHHH
HHHHHHHHHHHHHHHHHHHHHHHHHHHHHHHHHHHHHHHHHHHHHHHHHHHHHHHHHHHHHHHHHHHH
HHHHHHHHHHHHHHHHHHHHHHHHHHHHHHHHHHHHHHHHHHHHHHHHHHHHHHHHHHHHHHHHHHHH
HHHHHHHHHHHHHHHHHHHHHHHHHHHHHHHHHHHHHHHHHHHHHHHHHHHHHHHHHHHHHHHHHHHH
HHHHHHHHHHHHHHHHHHHHHHHHHHHHHHHHHHHHHHHHHHHHHHHHHHHHHHHHHHHHHHHHHHHH
HHHHHHHHHHHHHHHHHHHHHHHHHHHHHHHHHHHHHHHHHHHHHHHHHHHHHHHHHHHHHHHHHHHH
HHHHHHHHHHHHHHHHHHHHHHHHHHHHHHHHHHHHHHHHHHHHHHHHHHHHHHHHHHHHHHHHHHHH
HHHHHHHHHHHHHHHHHHHHHHHHHHHHHHHHHHHHHHHHHHHHHHHHHHHHHHHHHHHHHHHHHHHH
HHHHHHHHHHHHHHHHHHHHHHHHHHHHHHHHHHHHHHHHHHHHHHHHHHHHHHHHHHHHHHHHHHHH
HHHHHHHHHHHHHHHHHHHHHHHHHHHHHHHHHHHHHHHHHHHHHHHHHHHHHHHHHHHHHHHHHHHH
HHHHHHHHHHHHHHHHHHHHHHHHHHHHHHHHHHHHHHHHHHHHHHHHHHHHHHHHHHHHHHHHHHHH
HHHHHHHHHHHHHHHHHHHHHHHHHHHHHHHHHHHHHHHHHHHHHHHHHHHHHHHHHHHHHHHHHHHH
HHHHHHHHHHHHHHHHHHHHHHHHHHHHHHHHHHHHHHHHHHHHHHHHHHHHHHHHHHHHHHHHHHHH
HHHHHHHHHHHHHHHHHHHHHHHHHHHHHHHHHHHHHHHHHHHHHHHHHHHHHHHHHHHHHHHHHHHH
HHHHHHHHHHHHHHHHHHHHHHHHHHHHHHHHHHHHHHHHHHHHHHHHHHHHHHHHHHHHHHHHHHHH
HHHHHHHHHHHHHHHHHHHHHHHHHHHHHHHHHHHHHHHHHHHHHHHHHHHHHHHHHHHHHHHHHHHH
HHHHHHHHHHHHHHHHHHHHHHHHHHHHHHHHHHHHHHHHHHHHHHHHHHHHHHHHHHHHHHHHHHHH
HHHHHHHHHHHHHHHHHHHHHHHHHHHHHHHHHHHHHHHHHHHHHHHHHHHHHHHHHHHHHHHHHHHH

```

Subtest 10 LED / DAC display

This subtest displays as follows:

[Speed/CRT/Caps/Num/Scroll LED test]

- (1) Press [Fn + Pgdn] key ! ... Speed (red)
- (2) Press [Fn + Pgup] key ! ... Speed (green)
- (3) Press [Caps Lock] key ! ... Caps (on/off)
- (4) Press [Num lock] key ! ... Num (on/off)
- (5) Press [Overlay] key ! ... Fn (on/off)

PRESS [ENTER] KEY

Check Speed LED, Caps Lock LED, Num Lock LED, and Overlay LED light by pressing **Fn+PgDn**, **Fn+PgUp**, **Caps Lock** and **Fn**. Then press **Enter** and this subtest writes constant data (2Ah/15h) to DAC registers.

3.8 FLOPPY DISK TEST

CAUTION: Before running the floppy disk test, prepare a formatted work disk. Remove the Diagnostics Disk and insert the work disk into the FDD. The contents of the floppy disk will be erased.

OPERATION

1. When you select the floppy disk test of the DIAGNOSTIC TEST MENU, the following message will appear beneath the DIAGNOSTIC TEST MENU.

Test drive number select (1:FDD1,2:FDD2,0:FDD1&2) ?

2. Select the drive number containing the floppy disk to be tested and then press **Enter**. The following message will appear.

Media in drive#x mode (0:2DD,1:2D-2D,2:2D-2HD,3:2HD) ?

3. Select the media type of the floppy disk to be tested, then press **Enter**. The following message will appear.

Test start track (Enter:0/dd:00-79) ?

4. Select the start track number and press **Enter**. The subtest menu of the floppy disk test will appear. If you do not enter a start track number, the start track number will default to zero.
5. During the floppy disk test, the message shown below will appear.

```
FLOPPY DISK                                XXXXXXXX
SUB-TEST  : XX
PASS COUNT: XXXXX      ERROR COUNT: XXXXX
WRITE DATA: XX        READ DATA  : XX
ADDRESS   : XXXXXX     STATUS      : XXX
```

The **ADDRESS** number indicates that the first **XXX** shows a cylinder number, the third **X** shows a head number, and the last **XX** shows a sector number.

The **STATUS** number indicates that the first **X** shows a drive number and the last **XX** shows an error status code.

CONTENTS

Subtest 01 Sequential read

This subtest performs the cyclic redundancy check (CRC) with a continuous read operation of all tracks on a floppy disk.

The tracks available for the floppy disk formats are:

2D (Double-sided, double-density): Tracks 0 to 39.

2DD (Double-sided, double-density, double-track) and 2HD (Double-sided, high-density, double-track): Tracks 0 to 79.

The start track can be specified at the next stage.

Subtest 02 Sequential read/write

This subtest writes data to all the tracks (as defined above) continuously and then reads the data out and compares it with the original data.

(The data pattern is B5ADADh repeated.)

Subtest 03 Random address/data

This subtest writes random data to random addresses on all the tracks (as defined in subtest 01) and then reads the data out and compares it with the original data.

Subtest 04 Write specified address

This subtest writes the specified data on the specified address that you enter from the keyboard. You can specify the test data, track number, and head number.

Subtest 05 Read specified address

This subtest performs a read operation on the specified address that you enter from the keyboard. You can specify the track number and head number.

3.9 PRINTER TEST

CAUTION: *An IBM compatible printer must be connected to the system in order to execute this test. Confirm that the setup option External FDD/PRT is set to Printer.*

OPERATION

1. When you select this subtest, the following message will appear.

Select the channel number (1-3) ?

Select the printer channel number, then type in the number. The T2000SX supports three printer channels.

2. After pressing **Enter**, the subtest is executed.

CONTENTS

Subtest 01 Ripple pattern

This subtest prints characters for codes 20h through 7Eh line by line while shifting one character to the right at the beginning of each new line.

```
!"#$%&'()*+,-./0123456789;:<=>?@ABCDEFGHIJKLMNQRSTUvwxyz[\]^_`abcdefghijklmnop  
!"#$%&'()*+,-./0123456789;:<=>?@ABCDEFGHIJKLMNQRSTUvwxyz[\]^_`abcdefghijklmnop  
!"#$%&'()*+,-./0123456789;:<=>?@ABCDEFGHIJKLMNQRSTUvwxyz[\]^_`abcdefghijklmnop  
!"#$%&'()*+,-./0123456789;:<=>?@ABCDEFGHIJKLMNQRSTUvwxyz[\]^_`abcdefghijklmnopqr  
!"#$%&'()*+,-./0123456789;:<=>?@ABCDEFGHIJKLMNQRSTUvwxyz[\]^_`abcdefghijklmnopqr  
!"#$%&'()*+,-./0123456789;:<=>?@ABCDEFGHIJKLMNQRSTUvwxyz[\]^_`abcdefghijklmnopqrs  
!"#$%&'()*+,-./0123456789;:<=>?@ABCDEFGHIJKLMNQRSTUvwxyz[\]^_`abcdefghijklmnopqrs  
!"#$%&'()*+,-./0123456789;:<=>?@ABCDEFGHIJKLMNQRSTUvwxyz[\]^_`abcdefghijklmnopqrst  
!"#$%&'()*+,-./0123456789;:<=>?@ABCDEFGHIJKLMNQRSTUvwxyz[\]^_`abcdefghijklmnopqrstu  
!"#$%&'()*+,-./0123456789;:<=>?@ABCDEFGHIJKLMNQRSTUvwxyz[\]^_`abcdefghijklmnopqrstu  
!"#$%&'()*+,-./0123456789;:<=>?@ABCDEFGHIJKLMNQRSTUvwxyz[\]^_`abcdefghijklmnopqrstuv  
!"#$%&'()*+,-./0123456789;:<=>?@ABCDEFGHIJKLMNQRSTUvwxyz[\]^_`abcdefghijklmnopqrstuv  
!"#$%&'()*+,-./0123456789;:<=>?@ABCDEFGHIJKLMNQRSTUvwxyz[\]^_`abcdefghijklmnopqrstuvw  
!"#$%&'()*+,-./0123456789;:<=>?@ABCDEFGHIJKLMNQRSTUvwxyz[\]^_`abcdefghijklmnopqrstuvwxy
```

Subtest 02 Function

This subtest prints out various print type as shown below.

```
PRINTER TEST  
1. THIS LINE SHOWS NORMAL PRINT.  
2. THIS LINE SHOWS DOUBLE WIDTH PRINT.  
3. THIS LINE SHOWS COMPACT PRINT.  
4. THIS LINE SHOWS EMPHASIZED PRINT.  
5. THIS LINE SHOWS DOUBLE STRIKE PRINT.  
6. ALL CHARACTERS PRINT  
!"#$%&'()*+,-./0123456789;:<=>?@ABCDEFGHIJKLMNQRSTUvwxyz[\]^_`abcdefghijklmnop  
qrstuvwxyz{|}
```

Subtest 03 Wrap around

The data, control, and status lines will be checked with the printer wraparound connector.

NOTE: A printer wraparound connector is necessary for executing this test. The wiring diagram for the printer wraparound connector is described in Section 3.23.

3.10 ASYNC TEST

In subtest 01 through subtest 04, data transmission is done with the following format:

Speed: 9600 bps
Data: 8 bits and one parity bit (EVEN)
One stop bit
Data pattern: 20h to 7Eh

Subtest 01 Wrap around (board)

NOTE: The RS-232-C wraparound connector must be connected to Channel 1 to execute this subtest. The wiring diagram of the RS-232-C wraparound connector is described in Section 3.23.

A data send/receive test is performed with the wraparound connector for Channel 1.

Subtest 02 Board(#1) <=> board(#2)

The same test as subtest 01 is performed for the channel #1 <=> #2.

Note: The RS-232-C direct cable (9-pin to 9-pin) must be connected to Channels 1 and 2 to execute this subtest. The wiring diagram of the RS-232-C direct cable is described in Section 3.23.

Subtest 03 Point to Point (send)

NOTE: To execute this subtest, two machines must be connected with the RS-232-C direct cable. One machine should be set as 'send' and the other set as 'receive'. The wiring diagram for the RS-232-C direct cable is described in Section 3.23. By executing subtest 03 in one machine and subtest 04 in the other machine, the communication capability will be checked as follows.

A block of data (20h to 7Eh) is sent from one machine to the other, and then returned. The returned data is compared with the original data.

This test is used for checking whether the returned data is the same as the original data.

Subtest 04 Point to Point (receive)

This subtest is used with subtest 03 as described above.

Subtest 05 **Card modem loopback (1200BPS)**

NOTE: If there is no modem card in the system, this subtest can not be executed.

This subtest is used for checking if the data sent from the modem card to the RS-232-C line is correct. This can be done with the loopback function inside the modem card.

Subtest 06 **Interrupt test**

This subtest generates the interrupt request levels (IRQ) 4, 3, and 5 in this order, then checks if this function works correctly.

3.11 HARD DISK TEST

CAUTION: *The contents of the hard disk will be erased when subtest 02, 03, 04, 05, 06, 08, 09, or 10 is run. Before running the test, transfer the contents of the hard disk to a floppy disk. This can be done with the MS-DOS BACKUP command. After the test, enter the MS-DOS FDISK command, which will set the partition. Then enter the MS-DOS FORMAT command. (See the MS-DOS manual for details.)*

OPERATION

1. When you select the hard disk test on the DIAGNOSTICS TEST MENU, the following message will appear:

Test drive number select (1:HDD1,2:HDD2,0:HDD1&2) ?

2. Select the drive number of the hard disk to be tested and press **Enter**. The following message will appear:

HDC F/W error retry (1:yes,2:no) ?

3. This message is used for selecting to retry the operation when the hard disk controller detects an error. Select 1 or 2 and press **Enter**. The following message will appear:

Data compare error dump (1:no,2:yes) ?

4. This message is used for selecting to do a dump operation when a data compare error is detected. Select 1 or 2 and press **Enter**. The following message will appear:

Detail status display (1:no,2:yes) ?

5. This message is used for selecting to display the detail status on the screen or not. The detail status is described in Section 3.15. Select 1 or 2 and press **Enter**. Then the subtest menu of the hard disk test will appear.

6. During the hard disk test, the message shown below will appear.

```
HARD DISK TEST                XXXXXXXX

SUB-TEST   : XX
PASS COUNT: XXXXX             ERROR COUNT: XXXXX
WRITE DATA: XX               READ DATA  : XX
ADDRESS    : XXXXXX          STATUS     : XXX
```

The **ADDRESS** number indicates that the first **XXX** shows a cylinder number, the third **X** shows a head number, and the last **XX** shows a sector number.

The **STATUS** number indicates that the first **X** shows a drive number and the last **XX** shows an error status code.

CONTENTS

Subtest 01 Sequential read

This subtest performs forward reading of contents from track 0 to the maximum track and then performs reverse reading of the contents from the maximum track to track 0.

Subtest 02 Address uniqueness

This subtest writes the address data that is different sector by sector at each track, then reads and compares it to the original data. This subtest is done for all tracks.

There are three types of reads as listed below.

- Forward sequential
- Reverse sequential
- Random

Subtest 03 Random address/data

This subtest writes random data to random addresses (cylinder, head, and sector), and then reads the data out and compares it to the original data.

Subtest 04 Cross talk & peak shift

This subtest writes the eight types of worst pattern data (shown below) to a cylinder, then reads the data while shifting cylinder by cylinder.

Worst pattern data:

B5ADADh, 4A5252h, EB6DB6h, 149249h
63B63Bh, 9C49C4h, 2DB6DBh, D24924h

Subtest 05 Write/read/compare(CE)

This subtest writes the B5ADADh worst pattern data to the CE cylinder, and then reads the data out and compares it with the original data.

Subtest 06 Write specified address

This subtest writes specified data to a specified cylinder and head.

Subtest 07 Read specified address

This subtest reads data which has been written to a specified cylinder and head.

Subtest 08 **ECC circuit**

This subtest checks the ECC (error check and correction) circuit functions of a specified cylinder and head.

Subtest 09 **Sequential write**

This subtest writes 2-byte specified data to all cylinder.

Subtest 10 **W-R-C specified address**

This subtest writes to a specified cylinder and head, then reads and compares it with the original data.

3.12 REAL TIMER TEST

Subtest 01 Real time

A new date and time can be inputted during this subtest when the current date and time are displayed.

Operations for the test are as follows.

1. Select the subtest and the following message will appear:

```
Current date : xx-xx-xxxx
Current time : xx:xx:xx
```

```
Enter new date :
```

```
PRESS [ENTER] KEY TO EXIT TEST
```

2. If the current date is not correct, input the correct date and press **Enter**. Then the following message will appear:

```
Enter new time :
```

3. If the current time is not correct, input the correct time and press **Enter**. This returns you to the subtest menu of the Real Time Test.

Subtest 02 Backup memory

This subtest writes data (01h,02h,04h,....., 80h, FEh, FBh, FDh,....., 7Fh) to memory (addressed 0Eh to 3Fh), then reads and compares it with the original data.

The constant data is AAh, and 55h.

Subtest 03 Real time carry

CAUTION: When this test is executed, the current date and time are erased.

This subtest checks if the real time clock correctly increments the date and time displayed (month, day, year, hour, minute, and second).

3.13 NDP TEST

NOTE: This test cannot be executed if a numeric data processor (NDP) is not mounted on the system board.

Subtest 01 NDP test

This subtest checks the control word, status word, bus, and addition/multiplication functions.

3.14 ERROR CODE AND ERROR STATUS NAMES

Table 3-3 lists the error code and error status names.

Table 3-3 Error code and error status names

Device name	Error code	Error status name
(COMMON)	FF	Data Compare Error
SYSTEM	01	ROM Checksum Error
FDD	01 02 03 04 06 08 09 10 20 40 60 80 EE	Bad Command Address Mark Not Found Write Protected Record Not Found Media Removed DMA Overrun Error DMA Boundary Error CRC Error FDC Error Seek Error FDD Not Drive Time Out Error Write Buffer Error
PRINTER	01 08 10 20 40 80	Time Out Fault Select Line Out Of Paper Power Off Busy Line
ASYNC	01 02 04 08 10 20 40 80 88 33 34 36	[DSR ON] Time Out [CTS ON] Time Out RX Enable Time Out TX Buffer Full Time Out Parity Error Framing Error Overrun Error Line Status Error Modem Status Error No Carrier (Card Modem) Error (Card Modem) No Dial Tone (Card Modem)

Table 3-3 Error code and error status names (continued)

Device name	Error code	Error status name
HDD	01	Bad Command Error
	02	Bad Address Mark
	04	Record Not Found
	05	HDC Not Reset
	07	Drive Not Initialize
	09	DMA Boundary Error
	0A	Bad Sector Error
	0B	Bad Track Error
	10	ECC Error
	11	ECC Recover Enable
	20	HDC Error
	40	Seek Error
	80	Time Out Error
	AA	Drive Not Ready
	BB	Undefined
	CC	Write Fault
E0	Status Error	
F0	Not Sense Error (FF)	

3.15 HARD DISK TEST DETAIL STATUS

When an error occurs in the hard disk test, the following message will appear:

HDC status = XXXX

Detailed status of the hard disk test error is shown on the screen by an eight-unit number. The first XXXX is the error status and the last XXXX is not used.

The error status is composed of 2 bytes; the first byte shows the contents of the HDC status register in hexadecimal form and the other shows the error register of the HDC.

These contents are described in the Tables 3-4 and 3-5.

Table 3-4 HDC status register contents

Bit	Name	Description
7	BSY (Busy)	"0"--HDC is busy. "1"--HDC is ready.
6	DRDY (Drive ready)	"0"--Hard disk drive is not ready to accept any command. "1"--Hard disk drive is ready.
5	DWF (Drive write fault)	"0"--DWF error is not detected. "1"--Write fault condition occurs.
4	DSC (Drive seek complete)	"0"--The hard disk drive heads are not settled over a track. "1"--The hard disk drive heads are settled over a track.
3	DRQ (Data request)	"0"--Drive is not ready to transfer data. "1"--Drive is ready for data transfer.
2	CORR (Corrected data)	"0"--Otherwise "1"--Correctable data error is corrected.
1	IDX (Index)	"0"--Otherwise "1"--Index is sensed.
0	ERR (Error)	"0"--Otherwise "1"--The previous command was terminated with some error.

Table 3-5 Error register contents

Bit	Name	Description
7	BBK (Bad block mark)	"0"--Otherwise "1"--A bad block mark is detected.
6	UNC (Uncorrectable)	"0"--There is no uncorrectable data error. "1"--Uncorrectable data error has been detected.
5		Not used.
4	IDNF (Identification)	"0"--Otherwise "1"--There was no ID field in the requested sector.
3		Not used.
2	ABRT (Abort)	"0"--Otherwise "1"--Illegal command error or a drive status error occurs.
1	TK0 (Track 0)	"0"--The hard disk has found track 0 during a recalibrate command. "1"--The hard disk could not find track 0 during a recalibrate command.
0		Not used.

3.16 HARD DISK FORMAT

This command executes hard disk formatting.

There are two types of hard disk formatting:

1. Physical formatting
2. Logical formatting

This program is for physical formatting of the hard disk. It can execute the following items:

1. All track FORMAT
2. Good track FORMAT
3. Bad track FORMAT
4. Bad track CHECK

CAUTION: *The contents of the hard disk will be erased when this program is executed. Before executing the program, transfer the contents of the hard disk onto a floppy disk. This can be done with the MS-DOS BACKUP command. (See the MS-DOS manual for details.)*

3.16.1 Program Description

1. All track FORMAT

Performs physical formatting of the hard disk as shown in Table 3-6 below:

Table 3-6 Hard disk formatting sequence

Items	Description
Sector sequences	1
Cylinders	0 to 614
Heads	0 to 3
Sectors	1 to 17
Sector length (bps)	512
Bad track (maximum)	20

2. Good track FORMAT

Executes the formatting of a specified cylinder and track as a good track.

3. Bad track FORMAT

Executes the formatting of a specified cylinder and track as a bad track.

4. Bad track CHECK

Checks for bad tracks by performing a read operation for all tracks on the hard disk; a list of bad tracks is then displayed.

3.16.2 Operations

CAUTION: After physical formatting is finished, enter the MS-DOS FDISK command, which will set the partition. Then enter the MS-DOS FORMAT command. (See the MS-DOS manual for details.)

1. After pressing 2 and Enter in the DIAGNOSTICS MENU, the following message will appear.

```
DIAGNOSTICS - HARD DISK FORMAT : Vx.xx
 1 - All track FORMAT
 2 - Good track FORMAT
 3 - Bad track FORMAT
 4 - Bad track CHECK
 9 - Exit to DIAGNOSTICS MENU
```

Press [NUMBER] key ?

2. All track FORMAT selection

- (1) When all track FORMAT (1) is selected, the following message will appear:

```
Drive number select (1:#1,2:#2) ?
```

- (2) Select a drive number. Type the drive number and press Enter. The following message will appear:

```
Interleave number (1/1-8) ?
```

- (3) Select an interleave number (usually select 1). Type the number and press Enter. The following display will appear:

```
[ HDD TYPE ] : CYLINDER = xxxx
[ HDD TYPE ] : HEAD      = xx
[ HDD TYPE ] : SECTOR   = xx
```

```
[ WARNING : Current DISK data will be
             completely destroyed ]
```

Press [Bad track number (CCCCHH)] key ?

- (4) After pressing Enter, the [[cylinder, head = xxxx xx]] message will appear; then all cylinders of the hard disk are formatted and checked.

- (5) After formatting the hard disk the **Format complete** message will appear.
- (6) Press **Enter** to return to the HARD DISK FORMAT MENU.

3. Good track FORMAT or bad track FORMAT selection

- (1) When good track FORMAT or bad track FORMAT is selected, the following message will appear:

Drive number select (1:#1,2:#2) ?

- (2) Select a drive number. Type the drive number and press **Enter**. The following message will appear:

Interleave number (1/1-8) ?

- (3) Select an interleave number (usually select 1). Type the number and press **Enter**. The following message will appear:

```
[ HDD TYPE ] : CYLINDER = xxxx
[ HDD TYPE ] : HEAD      = xx
[ HDD TYPE ] : SECTOR    = xx
```

Press [Track number (CCCCHH)] key ?

- (4) Type a track number (six digits) and press **Enter**. (The first four digits are the cylinder number and the last two digits are the head number.) This executes the formatting of good tracks or bad tracks as indicated.

NOTE: *This program can format only one track per operation. If it is desired to format several good tracks or bad tracks, repeat the operation as many times as necessary.*

- (5) After formatting the track of the hard disk, the **Format complete** message will appear.
- (6) Press **Enter** to return to the HARD DISK FORMAT MENU.

4. **Bad track CHECK selection**

- (1) When bad track CHECK is selected, the following message will appear:

Drive number select (1:#1,2:#2) ?

- (2) Select a drive number. Type the drive number and press **Enter**. The following message will appear:

Interleave number (1/1-3) ?

- (3) Select an interleave number (usually select 1). Type the number and press **Enter**. Then the following message appears, and bad tracks of the hard disk are checked.

```
[ HDD TYPE ] : CYLINDER = xxxx
[ HDD TYPE ] : HEAD     = xx
[ HDD TYPE ] : SECTOR  = xx
```

[[cylinder, head = xxxx xx]]

- (4) After checking the bad tracks of the hard disk, the **Format complete** message will appear.
- (5) Press the **Enter** to return to the **HARD DISK FORMAT MENU**.

3.17 HEAD CLEANING

3.17.1 Program Description

This program executes head load/seek and read operations for head cleaning. A cleaning kit is necessary for cleaning the 3.5-inch FDD head.

3.17.2 Operations

1. After pressing **4** and **Enter** in the **DIAGNOSTICS MENU**, the following message will appear:

DIAGNOSTICS - FLOPPY DISK HEAD CLEANING : Vx.xx

Mount cleaning disk(s) on drive(s).
Press any key when ready.
2. After the above message appears, remove the **Diagnostics Disk**. Insert the cleaning disk and then press **Enter**.
3. When the **Cleaning start** message appears, **FDD head cleaning** will begin.
4. When cleaning is finished, the display automatically returns to the **DIAGNOSTICS MENU**.

2. Error information displayed on the screen can be manipulated with the following number keys.

Number

<u>Key</u>	<u>Function</u>
1	Scrolls the display to the next page.
2	Scrolls the display to the previous page.
3	Returns the display to the DIAGNOSTICS MENU.
4	Erases all error log information in RAM.
5	Outputs error log information to a printer.
6	Reads log information from a floppy disk.
7	Writes log information to a floppy disk.

3. In the case of "error retry OK", the capital "R" will be placed at the beginning of the error status. However, this is not added to the error count.

3.19 RUNNING TEST

3.19.1 Program Description

This program automatically runs the following tests in sequence.

1. System test (subtest number 01)
2. Memory test (subtest number 01, 02, 03, 04, 06, 07)
3. Display test (subtest number 01 to 08)
4. FDD test (subtest number 02)
5. Printer test (subtest number 03)
6. Async test (subtest number 01)
7. HDD test (subtest number 01, 05)

When running an FDD test, this system automatically decides if there is one or two FDDs.

3.19.2 Operations

CAUTION: *Do not forget to load a work disk. If a work disk is not loaded, an error will be generated during the FDD testing.*

1. Remove the Diagnostics Disk and insert the work disk into the floppy disk drive.
2. After pressing **6** and **Enter** in the DIAGNOSTICS MENU, the following message will appear:

Printer wrap around test (Y/N) ?

If you select Yes (by typing in **Y** and pressing **Enter**):

The printer wraparound test will be executed. A printer wraparound connector must be connected to the printer connector on the back of the unit to properly execute this test.

If you select No (by typing in **N** and pressing **Enter**):

The printer wraparound test will not be executed.

3. Type in **Y** or **N** and press **Enter**. The following message will appear.

Async#1 wrap around test (Y/N) ?

If you select Yes (by typing in **Y** and pressing **Enter**):

The ASYNC wraparound test will be executed. An RS-232-C wraparound connector must be connected to the COMMS connector on the back of the unit to properly execute this test.

If you select No (by typing in **N** and pressing **Enter**):

The ASYNC wraparound test will not be executed.

4. Type in **Y** or **N** and press **Enter**. The running test will begin.
5. This program is repeated continuously. To stop the program, press **Ctrl + Break**.

3.20 FDD UTILITIES

3.20.1 Program Description

These commands execute FDD formatting, copy floppy disks, and display the dump list for both the FDD and HDD.

1. FORMAT

CAUTION: *This command is only for testing a floppy disk drive and is different from the MS-DOS FORMAT command.*

This program can format a floppy disk (5.25-inch/3.5-inch) as follows:

- (1) 2D: Double-sided, double-density, 48/67.5 TPI, MFM mode, 512 bytes, 9 sectors/track.
- (2) 2DD: Double-sided, double-density, double-track, 96/135 TPI, MFM mode, 512 bytes, 9 sectors/track.
- (3) 2HD: Double-sided, high-density, double-track, 96/135 TPI, MFM mode, 512 bytes, 18 sectors/track.

2. COPY

This program copies from a source floppy disk to a target floppy disk.

3. DUMP

This program displays the contents of floppy disks (both 3.5-inch and 5.25-inch) and hard disks (designated sectors).

3.20.2 Operations

1. After pressing **7** and **Enter** in the DIAGNOSTICS MENU, the following message will appear:

```
[ FDD UTILITIES ]
```

```
1 : FORMAT
2 : COPY
3 : DUMP
9 : EXIT TO DIAGNOSTICS MENU
```

```
PRESS [1]-[9] KEY
```

2. **FORMAT** selection

- (1) When **FORMAT** is selected, the following message appears:

```
DIAGNOSTICS - FLOPPY DISK FORMAT : Vx.xx
```

```
Drive number select (1=A:,2=B:) ?
```

- (2) Select a drive number. Type the number and press **Enter**. The following message will appear:

```
Type select (0:2DD-2DD,1:2D-2D,2:2D-2HD,3:2HD-2HD) ?
```

- (3) Select a media/drive type number. Type the number and press **Enter**. A message similar to the one below will appear:

```
Warning : Disk data will be destroyed.
```

```
Insert work disk into drive A:
Press any key when ready.
```

- (4) Remove the Diagnostics Disk from the FDD and insert the work disk; press any key.

The following message will appear and formatting is executed:

```
[ FDD TYPE ] : TRACK = xxx
[ FDD TYPE ] : HEAD = x
[ FDD TYPE ] : SECTOR = xx
```

```
Format start
```

```
[[ track,head = xxx x ]]
```

After the floppy disk is formatted, the following message will appear:

```
Format complete
Another format (1:Yes/2:No) ?
```

- (5) If you type **1**, the display will return to the message in step (3) above. If you type **2**, the display will return to the DIAGNOSTICS MENU.

3. COPY selection

- (1) When COPY is selected, the following message appears:

Type select (0:2DD-2DD,1:2D-2D,2:2D-2HD,3:2HD-2HD) ?

- (2) Select a media/drive type number. Type the number and press Enter. A message similar to the one below will appear:

Insert source disk into drive A:
Press any key when ready.

- (3) Remove the Diagnostics Disk from the FDD and insert the source disk; press any key. The following message will appear and start the copying to memory:

```
[ FDD TYPE ] : TRACK = xxx
[ FDD TYPE ] : HEAD  = x
[ FDD TYPE ] : SECTOR = xx
```

Copy start

[[track,head = xxx x]]

Insert target disk into drive A:
Press any key when ready.

- (4) Remove the source disk from the FDD and insert the work disk (formatted); press any key. The [[track,head = xxx x]] message will appear and start the copying to a target disk. When copying cannot be done with one operation, the message in step (2) is displayed again. Repeat the operation.

After the floppy disk has been copied, the following message will appear:

Copy complete
Another copy (1:Yes/2:No) ?

- (5) If you type **1**, the display will return to the message in step (1) above. If you type **2**, the display will return to the DIAGNOSTICS MENU.

4. DUMP selection

- (1) When DUMP is selected, the following message appears:

Type select (0:2DD-2DD,1:2D-2D,2:2D-2HD,3:2HD-2HD) ?

- (2) Select a format type number. Type the number and press **Enter**. If 3 is selected the dump list for the hard disk is displayed automatically. The display will go to the message in step (5) below.

0: Displays a dump list for a floppy disk (2DD).
1: Displays a dump list for a floppy disk (2D).
2: Displays a dump list for a floppy disk (2HD).
3: Displays a dump list for a hard disk.

- (3) If 0, 1, or 2 is selected, the following message will appear:

Select FDD number (1:A/2:B) ?

- (4) Select an FDD drive number by typing in 1 or 2. The following message will appear:

Insert source disk into drive A:
Press any key when ready.

- (5) Remove the Diagnostics Disk from the FDD and insert a source disk. Press any key and the following message will appear:

-- Max. address --
[Track] = xxxx
[Head] = xx
[Sector] = xx

Track number ??

- (6) Type the track number and press **Enter**. The following message will appear:

Head number ?

- (7) Type the head number and press **Enter**. The following message will appear:

Sector number ??

- (8) Type the sector number and press **Enter**. The specified dump list will be displayed.

(9) After a dump list appears on the screen, the following message will appear:

Press number key (1:up,2:down,3:end) ?

(10) If you type **1**, the next sector dump will be displayed. If you type **2**, the previous sector dump will be displayed. If you type **3**, the following message will appear:

Another dump (1:Yes/2:No) ?

(11) If you type **1**, the display will return to the message shown after step (1) above. If you type **2**, the display will return to the **DIAGNOSTICS MENU**.

3.21 SYSTEM CONFIGURATION

3.21.1 Program Description

This program displays the following system configuration.

1. BIOS ROM version
2. Base memory size
3. Display mode
4. Number of floppy disk drives
5. Number of ASYNC ports
6. Number of hard disk drives
7. Number of printer ports
8. Co-processor presence
9. Extended memory size

3.21.2 Operations

After pressing **8** and **Enter** from the DIAGNOSTICS MENU, the following display will appear:

```
SYSTEM CONFIGURATION :  
* - BIOS ROM VERSION = Vx.xx  
* - 640KB MEMORY  
* - COLOR/GRAPH(80 Column)  
* - 1 FLOPPY DISK DRIVE(S)  
* - 1 ASYNC ADAPTER  
* - 1 HARD DISK DRIVE(S)  
* - 1 PRINTER ADAPTER  
* - 0 MATH CO-PROCESSOR  
* - xxxxxKB EXTENDED MEMORY
```

```
PRESS [Enter] Key ?
```

Press **Enter** to return to the DIAGNOSTICS MENU.

3.22 SETUP

3.22.1 Program Description

This program displays the current system setup information as listed below, and it can be changed automatically or manually.

1. MEMORY
 - (1) Total memory size
 - (2) Base memory size
 - (3) Hard RAM size
 - (4) Extended memory size

2. DISPLAY
 - (1) LCD display mode
 - (2) LCD gray scale
 - (3) LCD gray scale level

3. COMMUNICATION
 - (1) Serial port COM level
 - (2) Built-in modem COM level

4. HARD DISK
 - (1) Capacity

5. POWER SAVE OPTIONS
 - (1) Resume mode
 - (2) CPU sleep mode
 - (3) HDD auto off
 - (4) Display auto off
 - (5) Battery alarm
 - (6) Speaker
 - (7) Built-in modem power

6. OTHERS
 - (1) Popup
 - (2) Processing speed
 - (3) External FDD/PRT
 - (4) Printer port type

7. TIME & DATE

3.22.2 Accessing the SETUP

After pressing 0 and Enter from the DIAGNOSTICS MENU, a display similar to the following will appear:

```

                                T2000SX SETUP
----- MEMORY -----
Total           = 1024KB
Base            = 640KB
Hard RAM        = 0KB
Extended       = 384KB

----- DISPLAY -----
Display Adapter = VGA Compatible
LCD Display Mode = Color
LCD Gray Scale
= Normal:Semi-Bright, Intense:Bright
LCD Gray Scale Level= Normal 16 Levels

----- COMMUNICATION -----
Serial Port      COM Level
                 = COM1 (IRQ4/3F8H)
Built-in Modem  = COM2 (IRQ3/2F8H)

----- HARD DISK -----
Capacity        = 20MB

----- POWER SAVE OPTIONS -----
Resume Mode     = Boot
CPU Sleep Mode  = Enable
HDD Auto Off    = Disable
Display Auto Off = Disable
Battery Alarm   = On
Speaker         = On
Built-in Modem Power= On

----- OTHERS -----
Popup           = Enable
Processing Speed = High
External FDD/PRT = Printer
Printer Port Type = Output

----- TIME & DATE -----
XX:XX:XX,   XXX XXX XX, 199X

```

↑↓←→ : Select items, Space, BkSp : Change values
Esc : Exit without saving, Home : Set default values, End : Save and Reboot

This display is an example of setup options as they may currently be stored in memory.

Notice that selecting the type of floppy disk drive is not an option. The T2000SX automatically determines what type of internal floppy disk drive is installed. Also, you don't have to run the SETUP to use an external 5.25-inch floppy disk drive.

Press Esc if the setup options displayed accurately reflect your hardware configuration and no changes are necessary. The system restarts.

3.22.3 Changing SETUP Values

You can change all the SETUP options to their default settings or manually change certain options.

Automatic (Default) Setting

Follow these steps to set all the values to their default values.

1. Press **Home**. This instructs the program to reset all the options to their factory preset (default) values. The program calculates how much conventional and extended memory your T2000SX has, based on whether or not you have a memory expansion module (optional memory card) installed. SETUP stores the memory value it calculates in configuration memory along with the factory preset values for the other options. The T2000SX SETUP screen displays the new values.
2. Confirm that the new values are correct. To change any option(s), go to the next section, **Manual Setting**.
3. If the new values are correct, press **End**. The system restarts.

Manual Setting

Follow these steps to set any option(s) manually.

Note: The cursor, shown as a reverse video bar, indicates which option is selected for change.

1. Use the **...**, **↔**, **Y** and **≈** keys (or **Enter**) to move the cursor between the options.
2. When the option you want to change is highlighted, press either the **space bar** or **backspace** key to select alternate values.
3. When you are finished making changes, press **End** to record the new values in the configuration memory.
4. The SETUP menu displays this message:

Save Settings And Reboot? (Y/N)

Review your changes. If you need to make more alternations, press **N** and go back to step 1.

5. If the new values are correct, press **Y**. The system restarts.

3.22.4 SETUP Descriptions

This section explains the possible values for each SETUP option.

1. MEMORY

Configuration memory involves selecting how much RAM the system uses for each of the three types of memory: Base memory, Hard RAM, and Extended memory.

- (1) **Total**
This option displays the amount of standard RAM (1024KB) plus the amount of an optional memory card (1024KB, 2048KB, 4096KB or 8192KB).
- (2) **Base**
This option displays the amount of base memory, which is 640KB. This is for your information only and cannot be changed. Base memory is also called conventional memory.
- (3) **Hard RAM**
This option configures part of extended memory as Hard RAM. You can set 0KB (the default value for no Hard RAM), or from 128KB to the computer's maximum installed memory minus 640KB in 64KB increments. The default value is 0KB.
- (4) **Extended**
The SETUP program calculates the amount of extended memory and displays it along with the memory address where extended memory begins. Allocating memory for Hard RAM affects the size of extended memory.

Note: *There is not an option to select the expanded memory on the T200SX SETUP screen. You need to include the Expanded Memory Manager (EMM386.SYS) in your CONFIG.SYS file to emulate expanded memory in extended memory.*

2. DISPLAY

(1) LCD Display Mode

If there isn't a monitor attached to the T2000SX, this option determines whether the LCD uses monochrome mode or color mode. If there is a monitor attached to the T2000SX, the T2000SX's LCD display mode is determined by the mode of the monitor (either monochrome or color), and the setting for this option has no effect.

Color

Displays in color mode. The T2000SX converts 262,144 colors to 16 intensity levels of gray scale for the LCD. This is the preset setting.

Monochrome

Displays in the monochrome mode. The T2000SX converts 64 intensity levels of gray scale to 16 intensity levels of gray scale for the LCD.

(2) LCD Gray Scale

This specifies the relationship between the brightness levels for characters displayed in normal and intense display modes. A setting of **Bright** causes the T2000SX to use the maximum brightness level (gray scale level 15) to display characters. A setting of **Semi-Bright** causes the T2000SX to use a slightly lower brightness level (gray scale level 11).

The options are:

Normal:Semi-Bright, Intense:Bright (default)

Normal:Bright, Intense:Semi-Bright

If you're primarily using text-based programs (as opposed to graphics software), you may find that choosing **Normal:Bright, Intense:Semi-Bright** makes the text easier to read.

- (3) **LCD Gray Scale Level**
This specifies the gray levels and reverses how characters are displayed on the LCD screen.

Normal 16 Levels Displays black characters and graphics on a white background with 16 gray levels.
This is the default setting.

Reverse 16 Levels Displays white characters and graphics on a black background with 16 gray levels.

Normal 8 Levels Displays black characters and graphics on a white background with 8 gray levels.

Reverse 8 Levels Displays white characters and graphics on a black background with 8 gray levels.

Current Setting Displays with the current gray levels that were defined through VCHAD. When you select another **LCD Gray Scale Level** setting, this option is no longer displayed.

3. COMMUNICATION

This option allows you to change the I/O address and interrupt request (IRQ) levels of the serial ports. The T2000SX supports one serial port and one built-in modem port.

Since the I/O address and IRQ level of a serial port are automatically established according to its COM level, the SETUP program prompts you to specify only the COM level.

(1) **Serial Port**

This lets you assign the communications port name to the serial port (labeled **COMMS**).

COM1 Assigns COM1 to the serial port.
This is the default setting.

COM2 Assigns COM2 to the serial port.

Not Used Disables the serial (**COMMS**) port.

(2) **Built-in Modem**

This lets you assign the communications port name to the built-in modem port. If a modem is not installed, this setting has no effect.

COM1 Assigns COM1 to the built-in modem port.

COM2 Assigns COM2 to the built-in modem port.
This is the default setting.

Not Used Disables the built-in modem port.

*Note: You can assign a COM level only once. For example, the **Serial Port and Built-in Modem** cannot both be assigned to COM1.*

4. HARD DISK

Use either the **space bar** or **backspace** key to choose one of two hard disk options.

Capacity = xxMB Sets the hard disk to its standard setting.
This is the default setting.

No Drive Disconnects the hard disk. The T2000SX functions as if a hard disk is not attached.

5. POWER SAVE OPTIONS

This option enables, disables, and sets the T2000SX power saving features.

(1) **Resume Mode**

This option enables and disables the AutoResume feature. If you disable AutoResume, the system enables boot mode.

Boot Turns off the AutoResume feature.
This is the default setting.

Resume Turns on the AutoResume feature.

(2) **CPU Sleep Mode**

This option enables and disables the CPU sleep feature.

Enable Enables the CPU sleep mode. The computer will automatically shift to an operating speed of 2MHz when the processor is idle. This is the default setting.

Disable Disables the CPU sleep mode.

(3) **HDD Auto Off**

This option enables and disables the HDD automatic power off. When the AC adapter is attached this function is disabled, but the setting is unchanged.

Disable Disables HDD automatic power off.
This is the default setting.

xxMin. Automatically turns off power to the HDD if it is not used for the specified duration. The minutes of duration (**xx**) can be set to:

05 10 15 20 25 30 35

- (4) **Display Auto Off**
This option enables and disables the display automatic power off function. Enabling this option conserves battery power because it causes the T2000SX to turn the side-light off if you don't use the computer for the specified period of time. When the AC adapter is attached this function is disabled, but the setting is unchanged.

Disable Disables display automatic power off.
This is the default setting.

xxMin. Automatically turns off power to the FL of the sidelit LCD panel if it is not used for the specified duration. The minutes of duration (**xx**) can be set to:

03 06 09 12 15 18 21

- (5) **Battery Alarm**
This option enables and disables the low battery alarm, and battery pack removal alarm.

On Enables the alarms.
This is the default setting.

Off Disables the alarms.

- (6) **Speaker**
This option enables and disables the software use of the system speaker. Setting this option to **Off** also disables all system alarms, except the battery alarm.

On Enables software use of the system speaker.
This is the default setting.

Off Disables software use of the system speaker.

- (7) **Built-in Modem Power**
Use this option to supply power to the built-in modem. To conserve battery power, this option should be set to **Off** when a built-in modem is not in use.

On Turns on power to the built-in modem.
This is the default setting.

Off Turns off power to the built-in modem.

6. OTHERS

(1) Popup

This option enables and disables the Pop-up Window.

Enable Allows you to access the Pop-up Window.
This is the default setting.

Disable Disables the Pop-up Window.

(2) Processing Speed

This option selects the CPU and the system bus speeds. Some option cards are dependent on the system bus speed.

High Selects the maximum CPU speed and the maximum bus speed.
This is the default setting.

Normal Selects the maximum CPU speed and the low bus speed. This setting makes the T2000SX bus compatible with the IBM PC/AT bus.

Low Selects the low CPU speed and the low bus speed. This setting makes the T2000SX bus and CPU speeds compatible with IBM PC/AT.

(3) External FDD/PRT

This option assigns the function of the **PRT/FDD** port.

Printer Assigns the port as a printer port. A FDD connected to the **PRT/FDD** port cannot be accessed. An internal FDD is assigned as A.
This is the default setting.

FDD A Assigns the external FDD as A and the internal FDD as B.

FDD B Assigns the external FDD as B and the internal FDD as A.

(4) Printer Port Type

This option sets the printing capabilities of the **PRT/FDD** port.

Output Selects uni-directional operation.
This is the default setting.

Bi-Directional Selects bi-directional operation.

7. TIME & DATE

The **T2000SX SETUP** screen displays the current time and date stored in the clock/calender.

Use either the **space bar** or **backspace** key to change the time and date.

3.23 WIRING DIAGRAMS

1. Printer wraparound connector

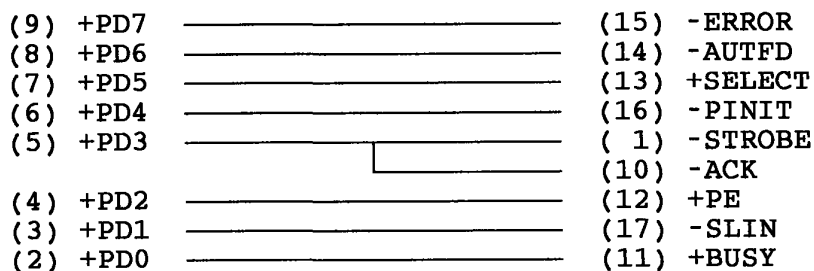

Figure 3-1 Printer wraparound connector

2. S-232-C Wraparound connector

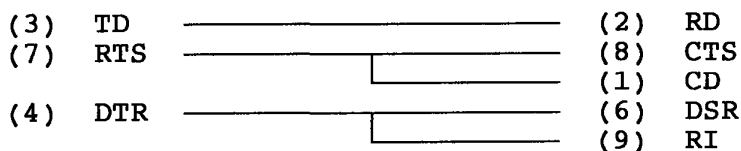

Figure 3-2 RS-232-C wraparound connector

3. RS-232-C direct cable (9-pin to 9-pin)

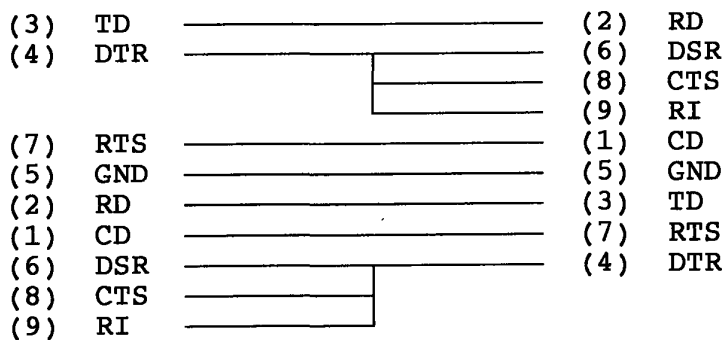

Figure 3-3 RS-232-C direct cable (9-pin to 9-pin)

4. RS-232-C direct cable (9-pin to 25-pin)

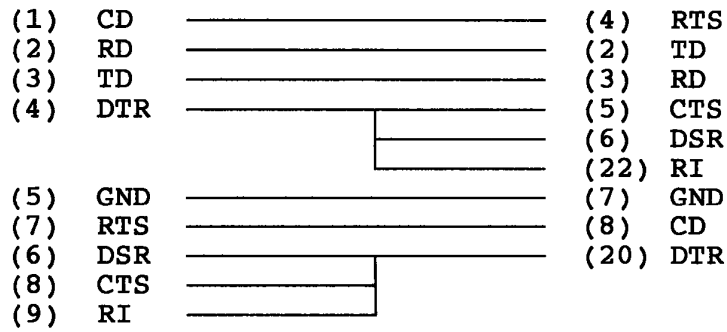

Figure 3-4 RS-232-C direct cable (9-pin to 25-pin)

This page intentionally left blank

4.1 GENERAL

This section gives detailed procedures for removing and replacing field replaceable units (FRUs).

FRUs are listed as follows:

1. System board (PCB FT2SYx)
2. LED board (PCB FT2LEx)
3. HDD board (PCB FT2HDx)
4. FL inverter board
5. Keyboard unit
6. Sub battery
7. RTC battery (Ni-Cd battery)
8. Modem assembly
9. Cover assembly
10. Base assembly
11. LED holder assembly
12. Terminal assembly
13. LCD mask
14. LCD module
15. LCD cable
16. Speaker bracket
17. Speaker
18. HDD bracket
19. HDD unit
20. FDD bracket
21. FDD unit

The following points must be kept in mind:

1. The system should never be disassembled unless there is a problem (abnormal operation, etc.).
2. Use only the tools specified below.
3. Keep the system free of dust and moisture.
4. The system is made of delicate electric components that are extremely sensitive to static electricity.
5. Whether using the system or storing it, the environment should be free of extreme heat, cold, and/or humidity.
6. After deciding the purpose of replacing an FRU and the procedures required, do not perform any other procedures which are not absolutely necessary.
7. Be sure to turn the POWER switch off before beginning, and disconnect the AC adapter and all external cables from the system.
8. Only perform those steps given in each procedure.
9. After replacing an FRU, confirm that the system is operating normally.

10. There are many pins on the PCBs and sharp edges on both the PCBs and shielding. Be careful when working with these components.
11. The numerous screws securing the system are not interchangeable. When reassembling the system, follow the appropriate procedures and figures because the various screw dimensions are given.
12. If the part description is different between the Maintenance Manual and the Parts Catalog, the Parts Catalog description will be given in parentheses for the first reference.

Tools needed for FRU replacement:

1. Two sizes of phillips head screwdrivers (for M2.5 and M3 screws)
2. Tweezers

Note: In the T2000SX, most of the screws are M2.5. The M3 screws are used for securing the FDD.

4.2 REMOVING/REPLACING THE BATTERY PACK

1. Turn off the power to the system unit and remove the AC adapter from the system unit.
2. Remove the battery pack (A) from the system unit.

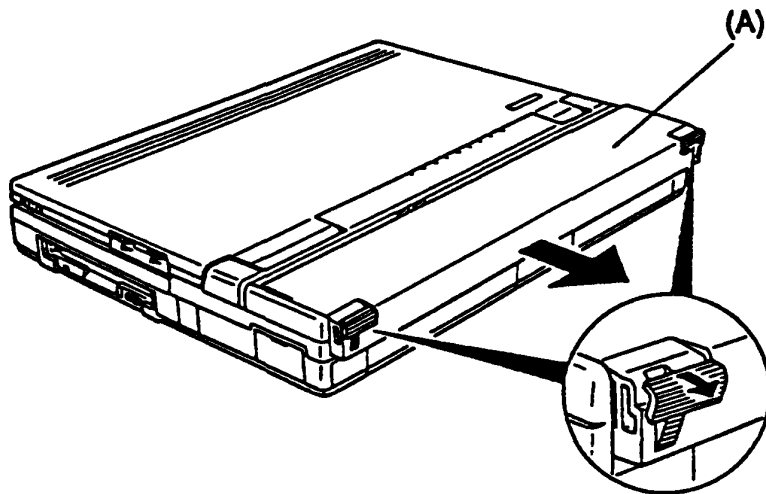

Figure 4-1 Removing the battery pack

3. To install the battery pack, follow the above procedure in reverse.

4.3 REMOVING/REPLACING THE MODEM ASSEMBLY

1. Turn off the power to the system unit and remove the AC adapter from the system unit.
2. Turn the system unit upside down and remove the two screws (M2.5x6 silver) (A). Then remove the modem cover (B) from the system unit.

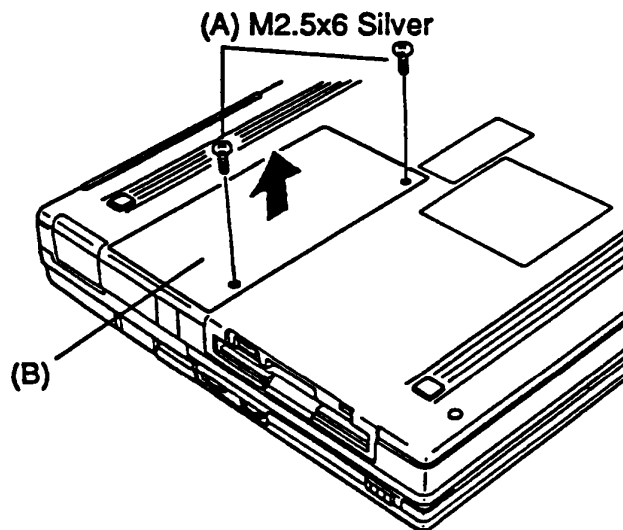

Figure 4-2 Removing the modem cover

3. Remove the two screws (M2.5x6 silver) (C) and then remove the modem assembly (D) from the system unit.

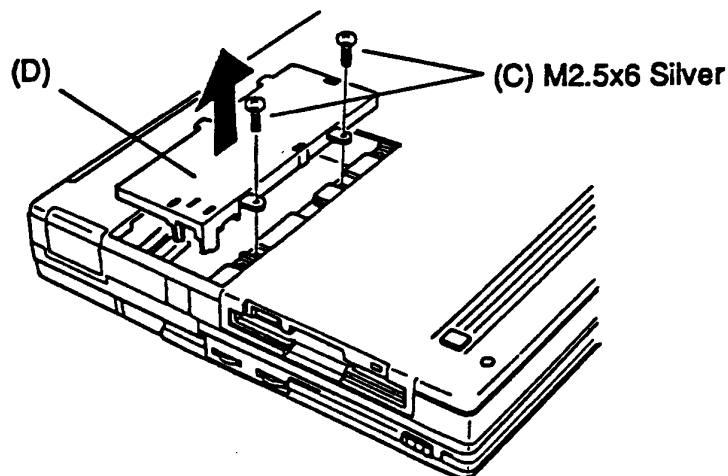

Figure 4-3 Removing the modem assembly

4. To install the modem assembly, follow the above procedure in reverse.

4.4 REMOVING/REPLACING THE OPTIONAL MEMORY CARD

1. Turn off the power to the system unit and remove the AC adapter from the system unit.
2. Turn the system unit upside down and remove the memory card slot cover (option cover) (A) from the system unit.

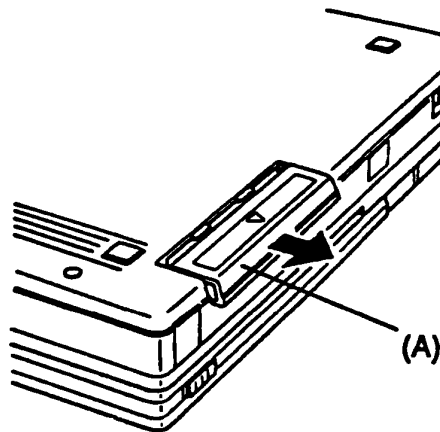

Figure 4-4 Removing the memory card slot cover

3. Remove the optional memory card (B) from the system unit.

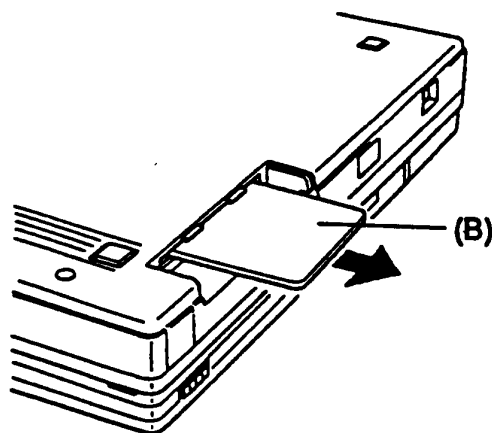

Figure 4-5 Removing the optional memory card

4. To install the optional memory card, follow the above procedure in reverse.

4.5 REMOVING/REPLACING THE KEYBOARD UNIT, SUB BATTERY, AND SPEAKER

1. Remove the battery pack from the system unit as directed in Section 4.2.
2. Turn the system unit upside down and remove the three screws (M2.5x8 silver) (A) that attach the keyboard unit to the system unit.

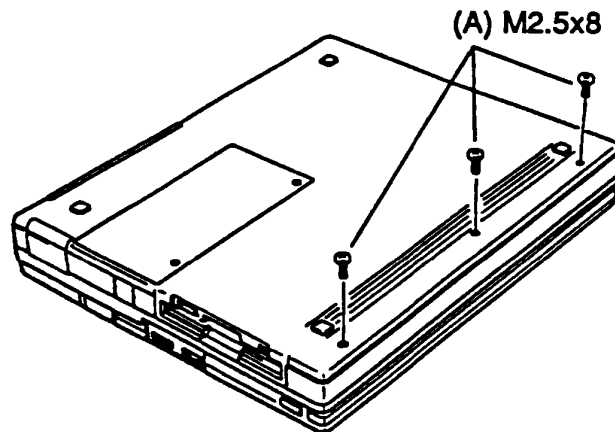

Figure 4-6 Removing the three screws

3. Carefully turn the system unit back over and open the display.
4. Lift up the front edge of the keyboard cover (B) and place it in front of the system unit.

5. Disconnect the keyboard cables (C) from PJ7 (D) and PJ8 (E) located on the system board (PCB FT2SYx).

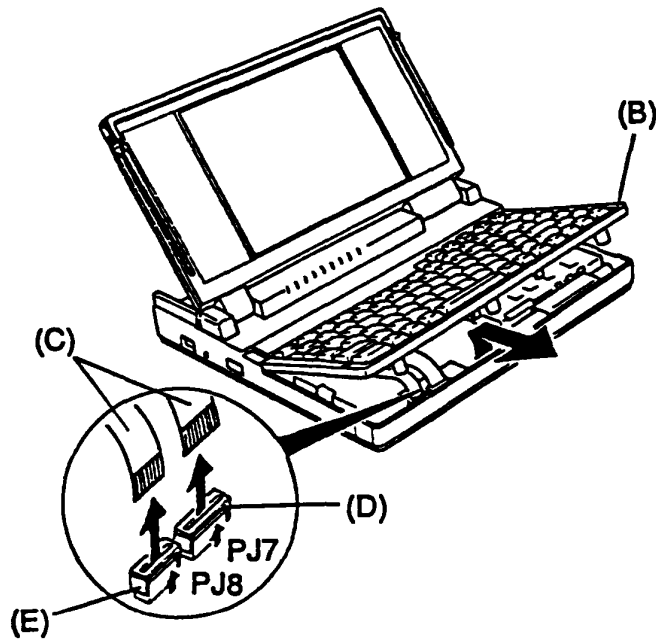

Figure 4-7 Removing the keyboard unit

6. Unlatch the eleven latches (F) on the keyboard cover (G) and pull out the keyboard unit (H).

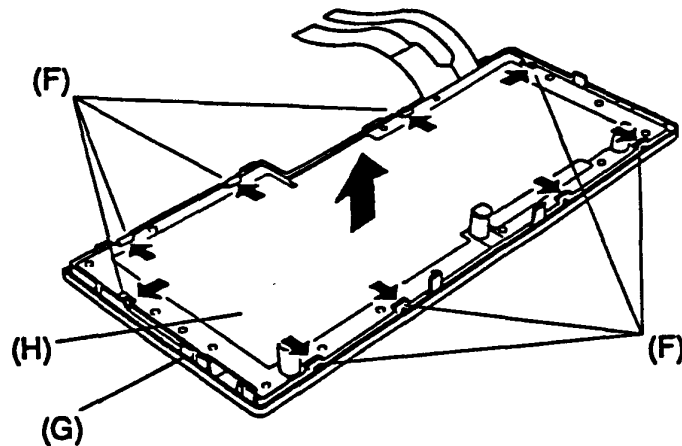

Figure 4-8 Removing the keyboard cover

7. Disconnect the sub battery cable (I) from PJ703 (J) located on the system board (PCB FT2SYx). Then remove the sub battery (K) from the system unit.

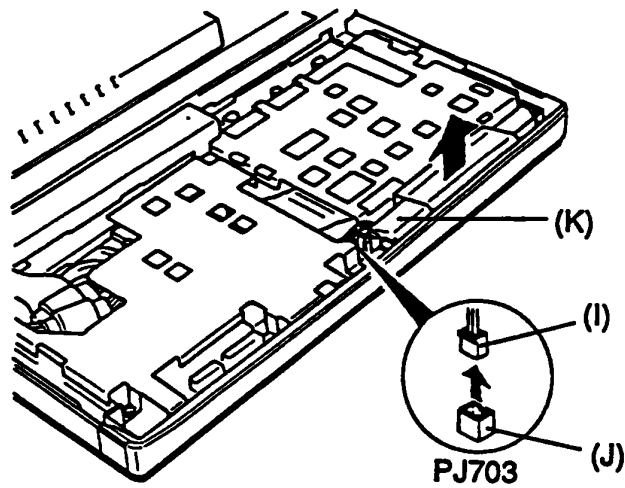

Figure 4-9 Removing the sub battery

8. Remove the seven screws (M2.5x4) (L), then remove the shield plate (M) from the system unit.

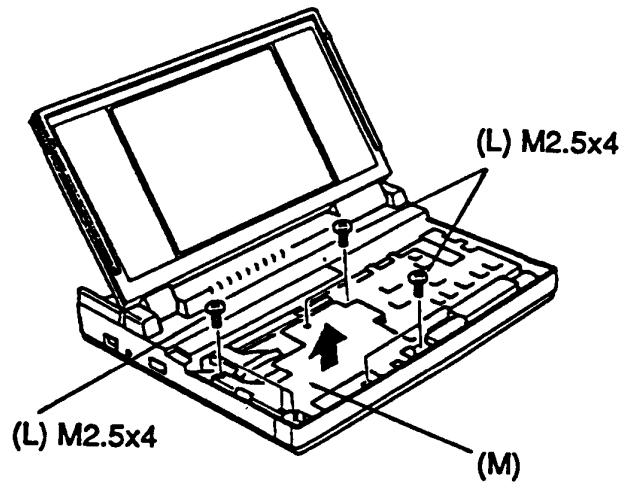

Figure 4-10 Removing the shield plate

9. Remove the speaker bracket (N) from the system unit and disconnect the speaker cable (O) from PJ11 (P) located on the system board (PCB FT2SYx).

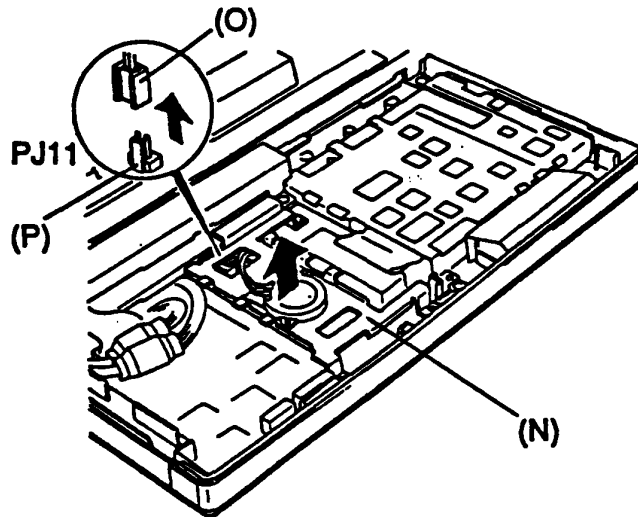

Figure 4-11 Removing the speaker bracket

10. Remove the two screws (M2.5x4) (Q) and then remove the speaker (R) from the speaker bracket.

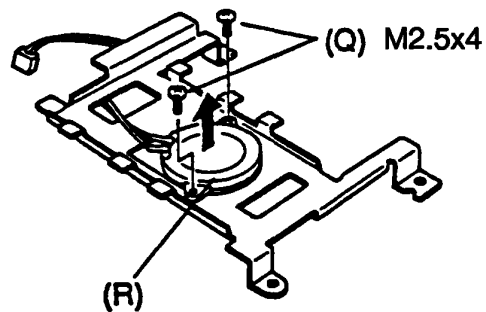

Figure 4-12 Removing the speaker

11. To install the keyboard unit, sub battery, and speaker, follow the above procedure in reverse.

4.6 REMOVING/REPLACING THE LCD MODULE AND FL INVERTER BOARD

1. Remove the battery pack from the system unit as directed in Section 4.2.
2. Open the display and then remove the two rubbers (cushion LCD) (A) and name plate assembly (B) from the LCD mask (C).
3. Remove the four screws (M2.5x6) (D) and unlatch the ten latches (E) on the LCD mask.

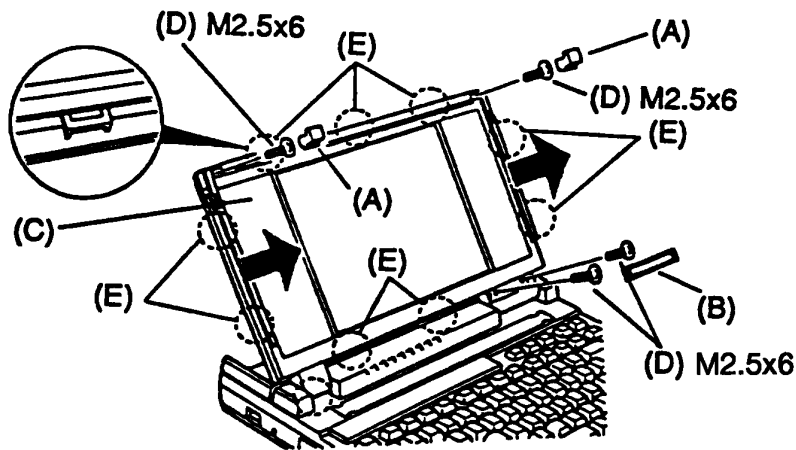

Figure 4-13 Removing the LCD mask

4. Remove the two screws (M2.5x4) (F). Then lift the FL inverter board toward you and disconnect the three cables (G) from CN1 (H), CN2 (I), and CN3 (J) located on the FL inverter board.

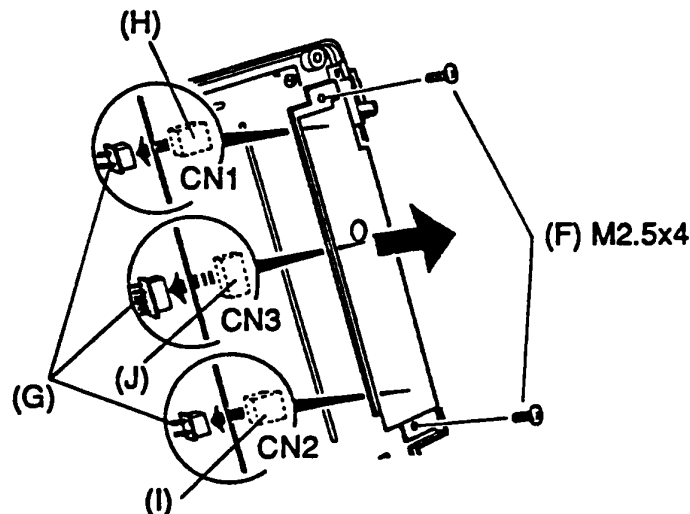

Figure 4-14 Removing the FL inverter board

5. Disconnect the LCD cable (K) from CN1 (L) and CN2 (M) located on the LCD module (N) while lifting the insulator (O). Then remove the four screws (M2.5x4) (P) and remove the ground cable (Q - not shown) and LCD module from the system unit.

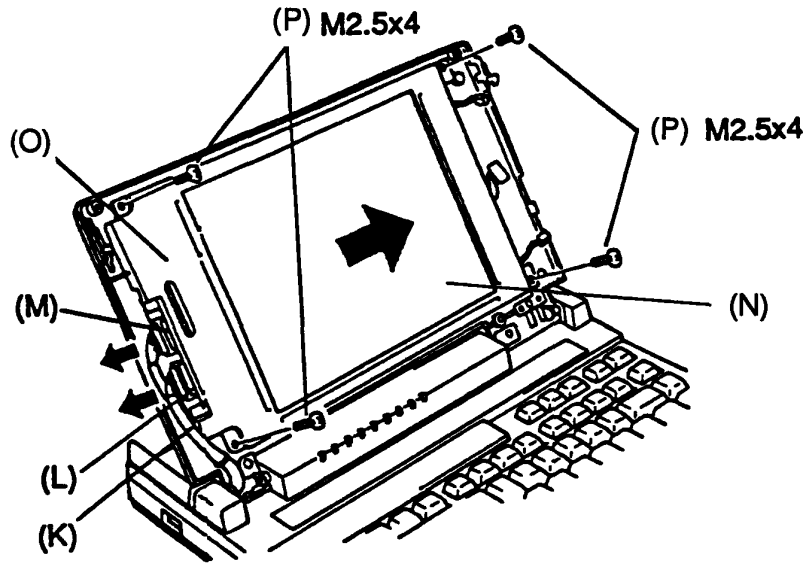

Figure 4-15 Removing the LCD module

6. To install the LCD module and FL inverter board, follow the above procedure in reverse.

4.7 REMOVING/REPLACING THE COVER ASSEMBLY

1. Remove the keyboard unit, LCD module, and FL inverter board from the system unit as directed in Sections 4.5 and 4.6.
2. Disconnect the LED board (PCB FT2LE_x) (A) and LCD cable (B) from PJ9 (C) and PJ12 (D) located on the system board (PCB FT2SY_x) and remove the seven screws (M2.5x6 silver) (E). Then remove the cover assembly (F) from the system unit.

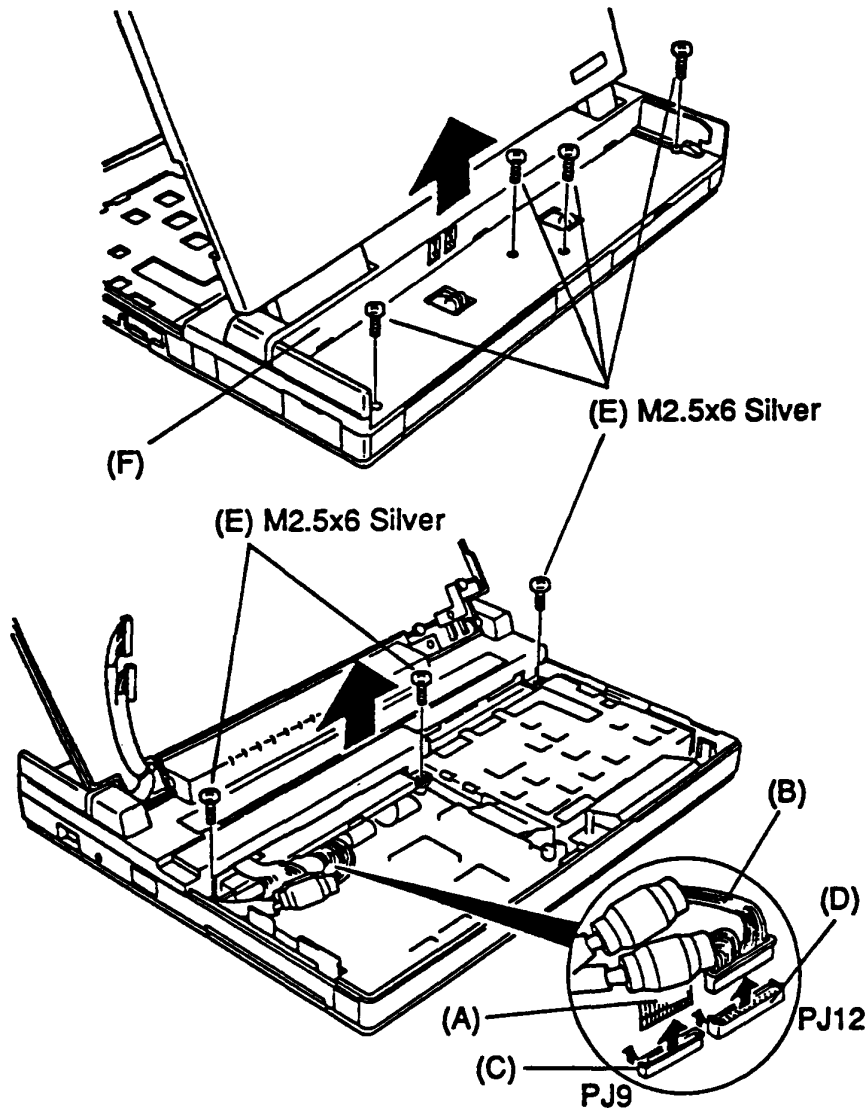

Figure 4-16 Removing the cover assembly

3. Remove the one screw (M2.5x4) (G - not shown) and remove the LCD cable plate (plate harness) (H - not shown).
4. Remove the two screws (tap screws) (I) and remove the hinge holder (J). Then remove the LCD cable from the cover assembly.

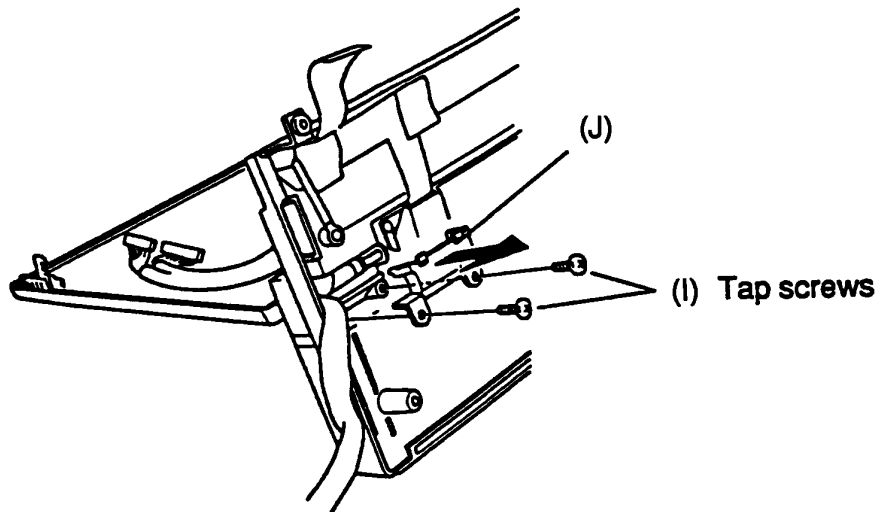

Figure 4-17 Removing the LCD cable

5. Disconnect the sensor cable (K) and unclamp the two clamps (L) to remove the sensor cable.
6. Remove the two screws (M2.5x4) (M) and then remove the LED holder assembly (N) from the cover assembly.

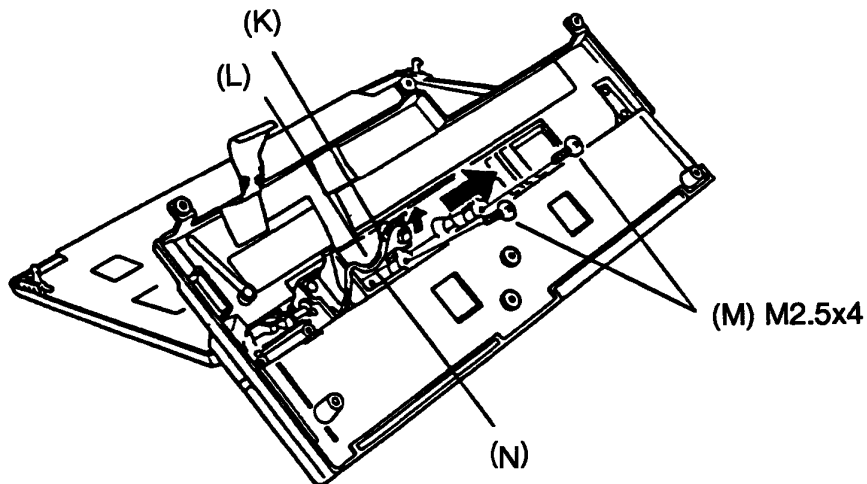

Figure 4-18 Removing the LED holder assembly

7. Disconnect the RTC battery (Ni-Cd battery) (O) and thermistor cable (P) from the LED board (PCB FT2LEx) (Q) and remove the one screw (M2.5x4) (R).
8. Unlatch the four latches (S) on the LED holder assembly, then remove the LED board (PCB FT2LEx) from the LED holder assembly.

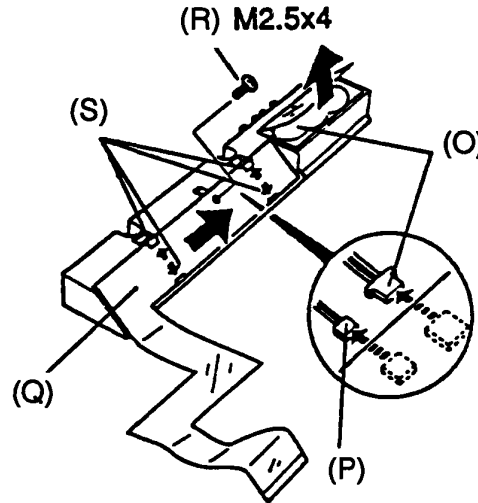

Figure 4-19 Removing the LED board

9. To install the cover assembly, LCD cable, LED holder assembly, RTC battery (Ni-Cd battery), and LED board (PCB FT2LEx), follow the above procedure in reverse.

4.8 REMOVING/REPLACING THE TERMINAL ASSEMBLY AND HDD UNIT

1. Remove the cover assembly from the system unit as directed in Section 4.7.
2. Disconnect the battery cable (A) from PJ702 (B) located on the system board (PCB FT2SYx) and remove the terminal assembly (C) from the system unit.

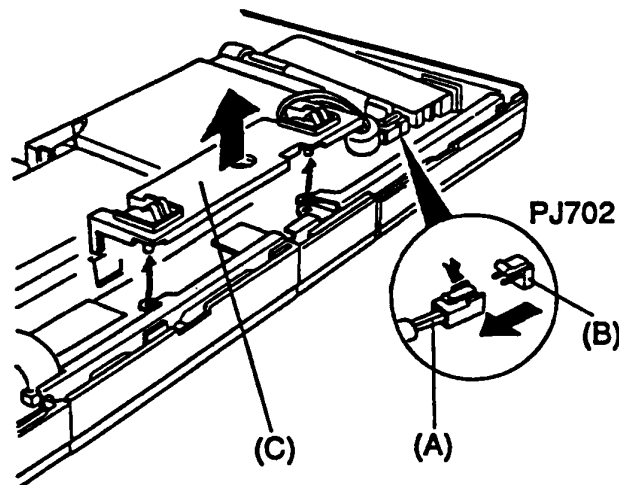

Figure 4-20 Removing the terminal assembly

3. Remove the two screws (M2.5x4) (D) and then lift up the HDD bracket (E) from the system unit.
4. Disconnect the HDD board (PCB FT2HDx, HDD flex cable) (F) from PJ3 and PJ4 on the system board (G).

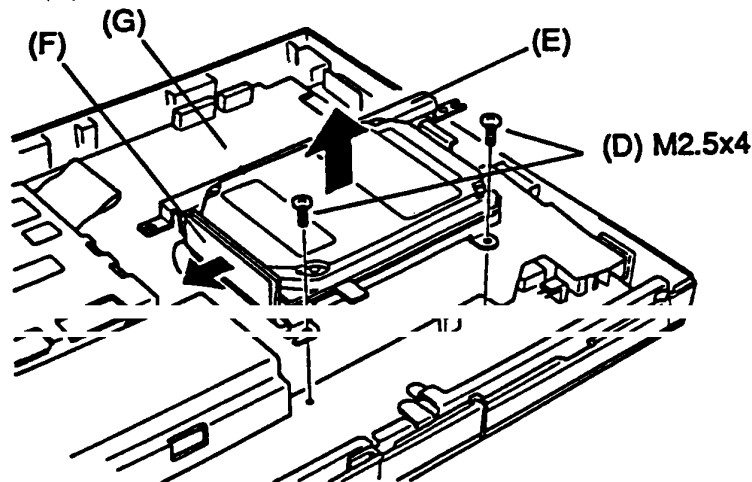

Figure 4-21 Removing the HDD bracket

5. Remove the four screws (H) and then remove the HDD bracket from the HDD unit.

Note: These four screws may be one of two sizes: inch screws or M3x4 screws. The inch screws are used for the Conner 20MB HDD (CP-2024) and JVC 40MB HDD (JD-E2850P). The M3x4 screws are used for the Conner 40MB HDD (CP-2044).

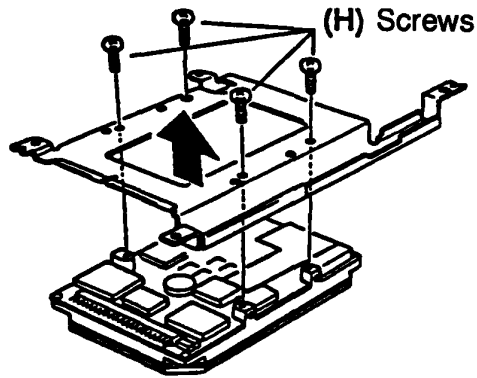

Figure 4-22 Removing the HDD unit

6. To install the terminal assembly and HDD unit, follow the above procedure in reverse.

4.9 REMOVING/REPLACING THE FDD UNIT

1. Remove the HDD bracket from the system unit as directed in Section 4.8.
2. Disconnect the FDD cable (A) from PJ16 (B) located on the system board (PCB FT2SYx) and remove the two screws (M2.5x4) (C). Then remove the FDD bracket (D).

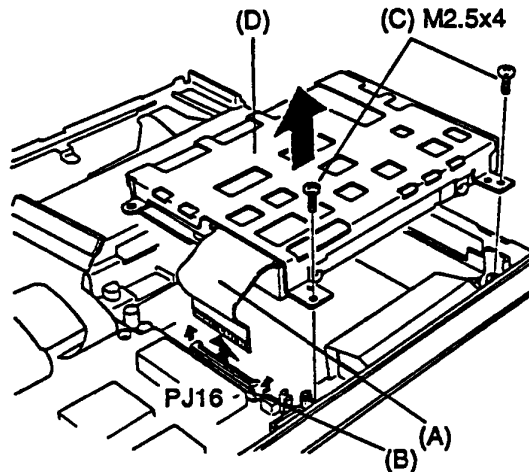

Figure 4-23 Removing the FDD bracket

3. Remove the four screws (E) and then remove the FDD bracket from the FDD unit (F).

Note: These four screws may be one of two types: M3x4 silver screws or special screws. The M3x4 silver screws are used for the Matsushita FDD. The special screws are used for the Citizen FDD.

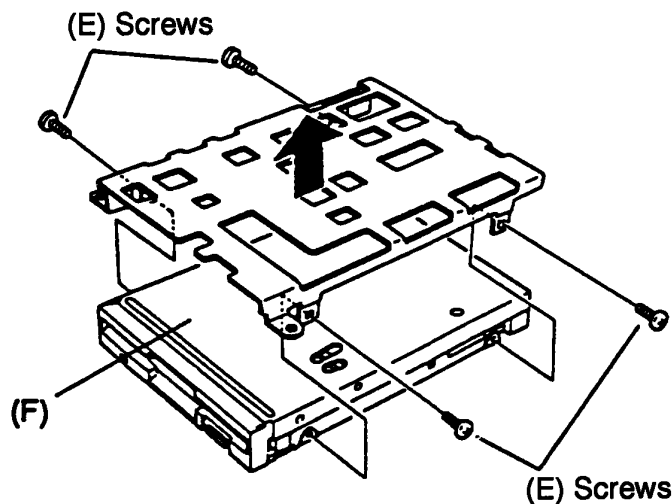

Figure 4-24 Removing the FDD unit

4. To install the FDD unit, follow the above procedure in reverse.

4.10 REMOVING/REPLACING THE SYSTEM BOARD

1. Remove the FDD bracket from the system unit as directed in Section 4.9.
2. Remove the expansion bus connector cover (cover connector) (A) and open the connector cover (B).
3. Disconnect the HDD board (PCB FT2HDx) (C) from PJ3 (D) and PJ4 (E) located on the system board (PCB FT2SYx).
4. Remove the five screws (four M2.5x4 and one M2.5x6 silver) (F) and then remove the system board (PCB FT2SYx) from the base assembly (G).

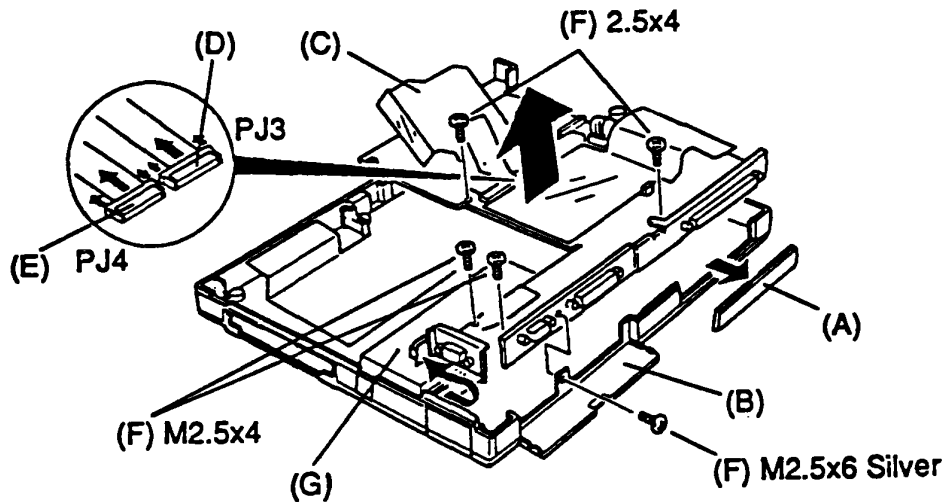

Figure 4-25 Removing the system board

5. To install the system board (PCB FT2SYx), follow the above procedure in reverse.

APPENDIX A BOARD LAYOUT

A.1 System board FT2SYx (ICs)

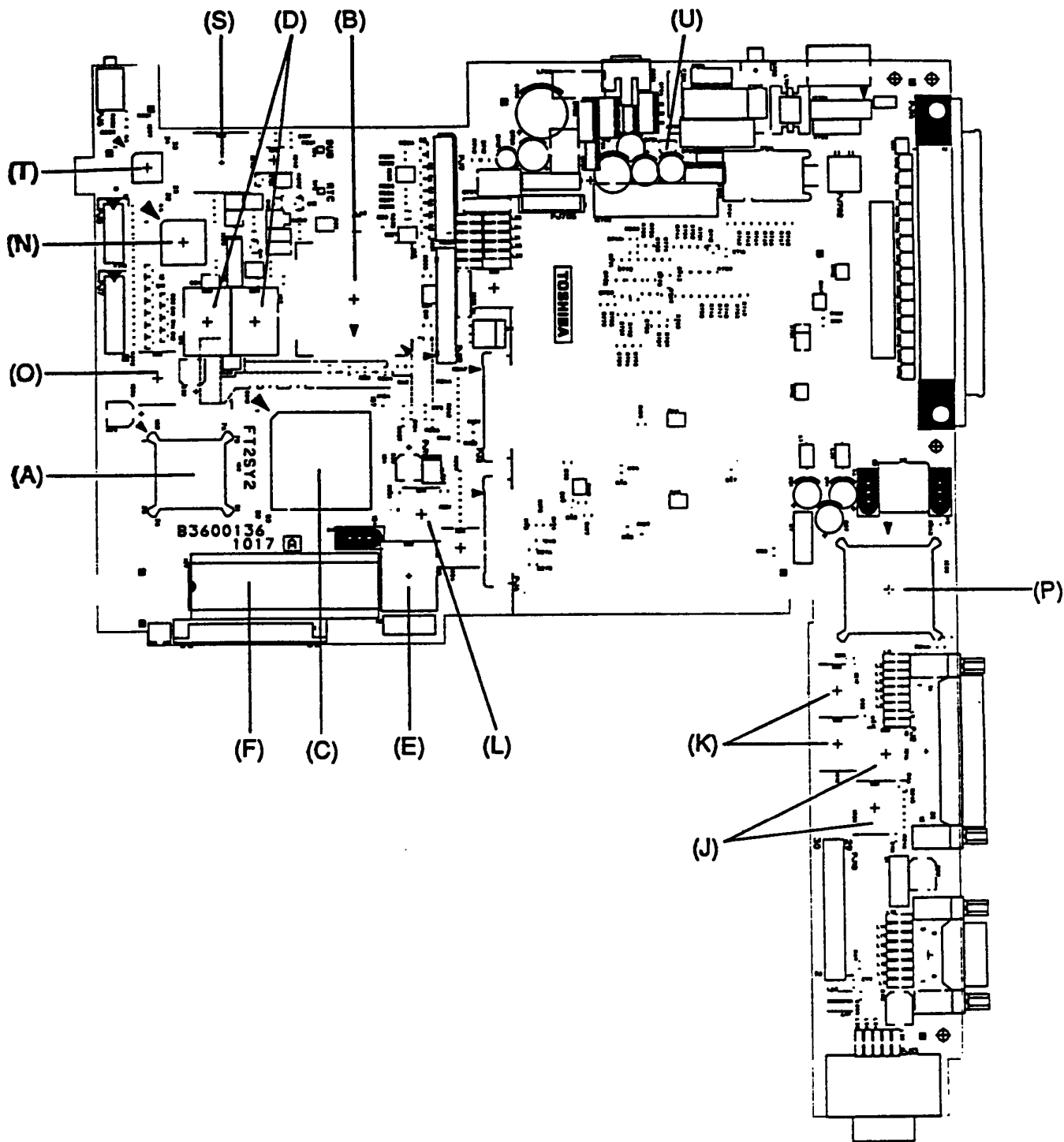

Figure A-1 System board FT2SYx (ICs) (Front)

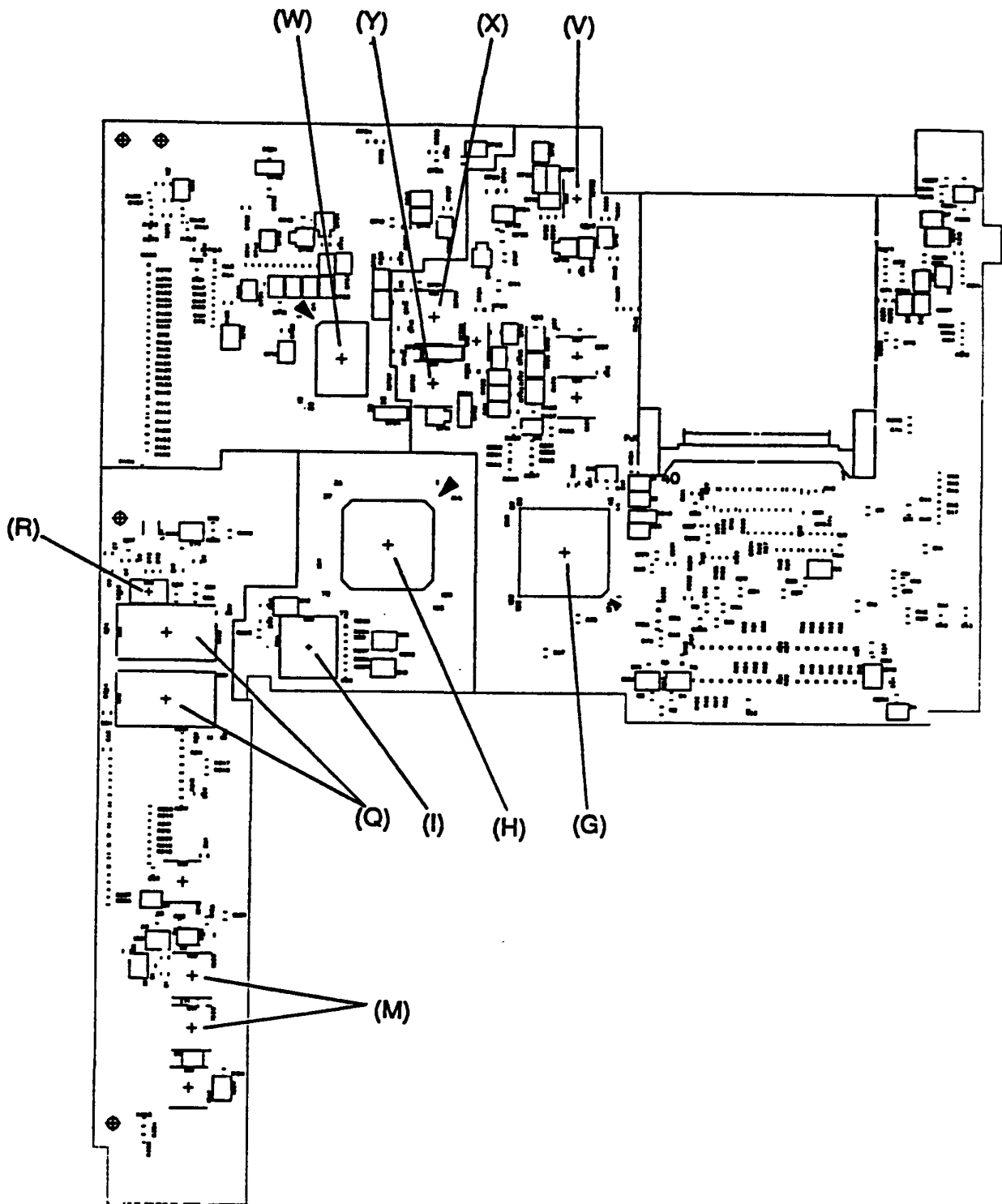

Figure A-1 System board FT2SYx (ICs) (Back)

Table A-1 ICs on the system board FT2SYx

Mark	Number	Name
(A)	IC2	CPU: Central Processing Unit (80386SX-16)
(B)	IC3	NDP: Numeric Data Processor (80387SX-16)
(C)	IC4	GA-SYS CNT: System Control Gate Array
(D)	IC6,7	System RAM
(E)	IC8	Backup RAM
(F)	IC9	BIOS ROM
(G)	IC10	GA-IO CNT: I/O Control Gate Array
(H)	IC11	SI: Super Integration (T9778)
(I)	IC14	VFO: Variable Frequency Oscillator (L8568AM)
(J)	IC16,20	FDD Driver (I62007)
(K)	IC17,18	Printer Driver (I62007)
(L)	IC21	HDD Driver (HC244)
(M)	IC22,23	RS-232-C Driver (I145406S)
(N)	IC25	KBSC: Keyboard Scan Controller (80C50)
(O)	IC26	Keyboard Driver (HC240)
(P)	IC30	PVGA1F: VGA Flat Panel Display Controller (90C20)
(Q)	IC31,32	Video RAM
(R)	IC34	Voltage Regulator (L2951)
(S)	IC46	RTC: Real Time Clock (146818AF)
(T)	IC59	KBIC: Keyboard Interrupt Controller (80C42)
(U)	IC704	Regulator
(V)	IC705	Backup Power Controller (L1025)
(W)	IC707	Power Supply Controller (U47C660)
(X)	IC708	Power Supply Driver (L1600)
(Y)	IC709	Switching Regulator (L1451)

A.2 System board FT2SYx (OSCs)

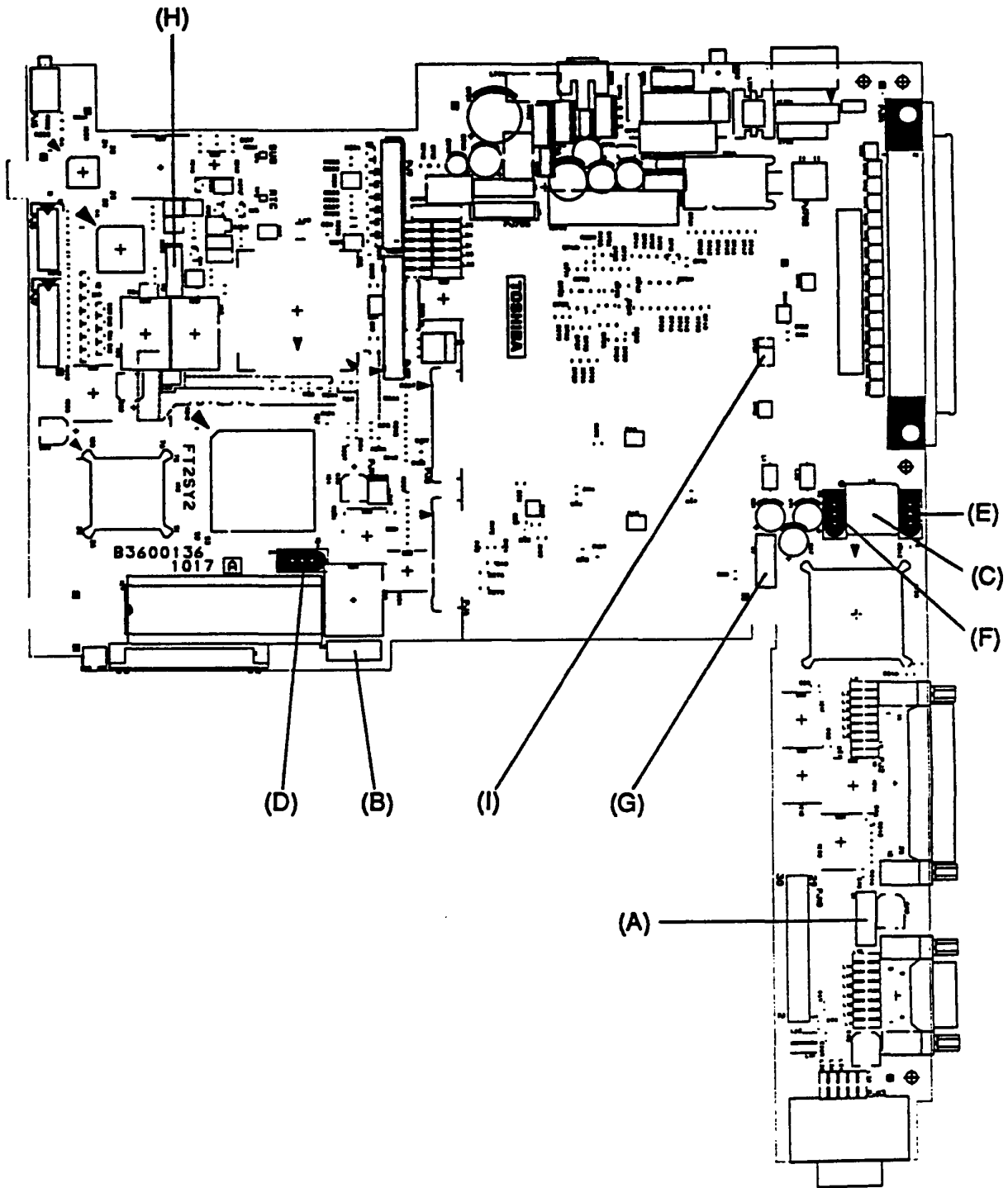

Figure A-2 System board FT2SYx (OSCs)

Table A-2 OSCs on the system board FT2SYx

Mark	Number	Name
(A)	X1	14.7456MHz Oscillator
(B)	X2	14.31818MHz Oscillator
(C)	X3	44.9MHz Oscillator
(D)	X4	32.0MHz Oscillator
(E)	X5	28.322MHz Oscillator
(F)	X6	25.175MHz Oscillator
(G)	X7	24MHz Oscillator
(H)	X8	32.768KHz Oscillator
(I)	X701	500KHz Oscillator

A.3 System board FT2SYx (Connectors)

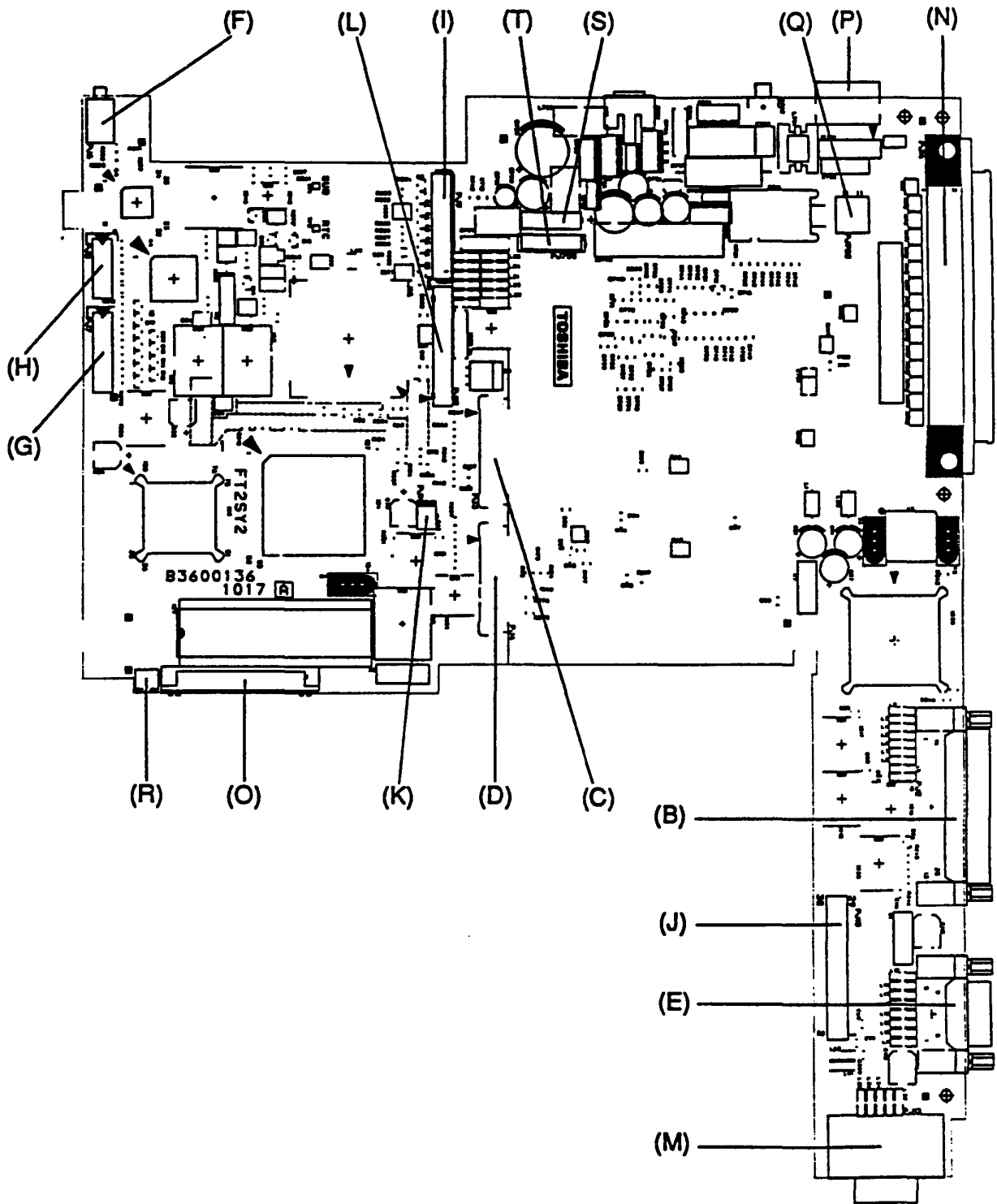

Figure A-3 System board FT2SYx (Connectors) (Front)

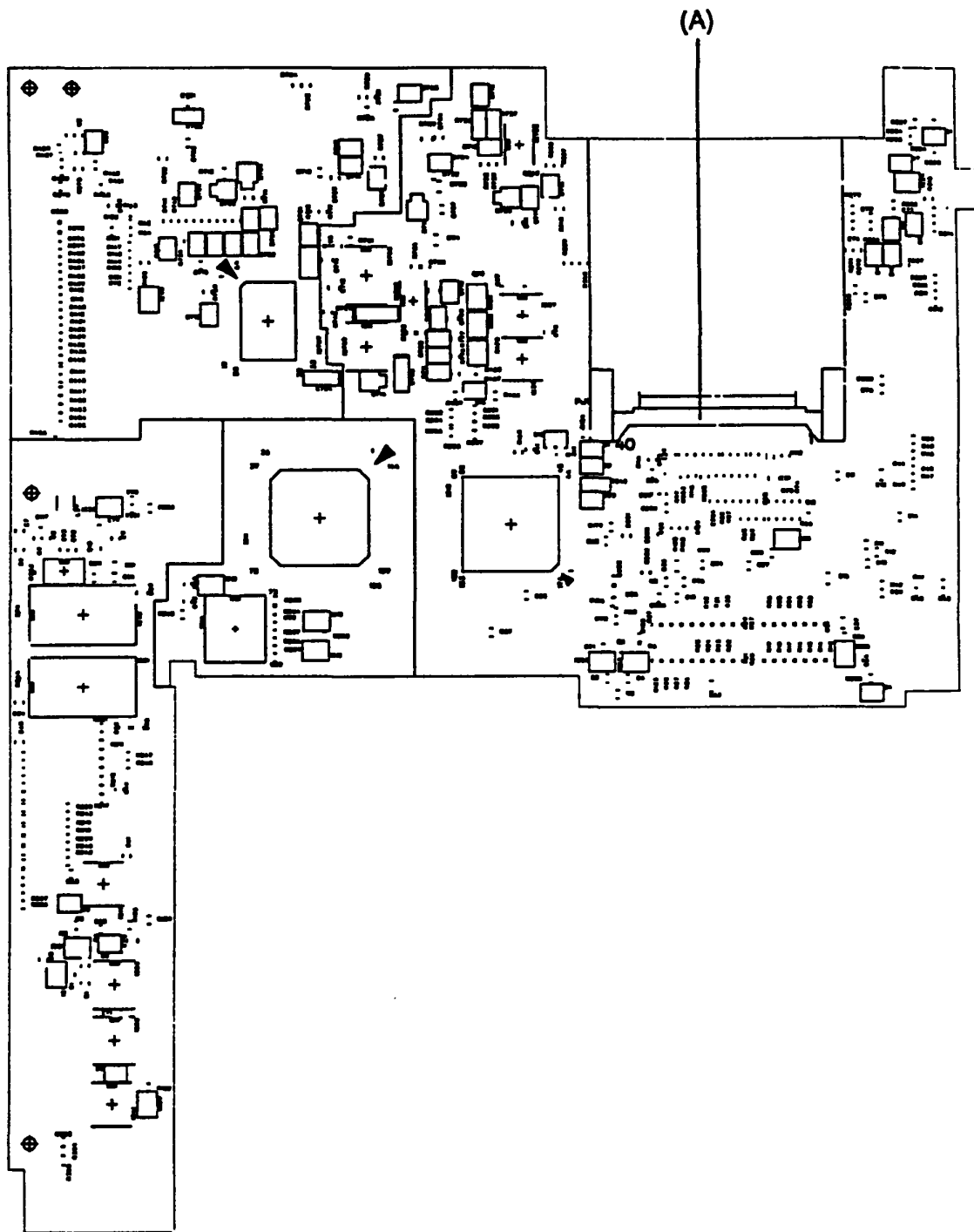

Figure A-3 System board FT2SYx (Connectors) (Back)

Table A-3 Connectors on the system board FT2SYx

Mark	Number	Name	Number of pins
(A)	PJ1	Expansion Memory I/F Connector	40
(B)	PJ2	Printer/FDD I/F Connector	25
(C)	PJ3	HDD I/F Connector (Left)	22
(D)	PJ4	HDD I/F Connector (Right)	22
(E)	PJ5	RS-232-C I/F Connector	9
(F)	PJ6	Numeric Keypad I/F Connector	3
(G)	PJ7	Keyboard I/F Connector (Right)	12
(H)	PJ8	Keyboard I/F Connector (Left)	8
(I)	PJ9	LED Board I/F Connector	22
(J)	PJ10	Built-in Modem I/F Connector	30
(K)	PJ11	Speaker I/F Connector	2
(L)	PJ12	LCD I/F Connector	30
(M)	PJ13	CRT I/F Connector	15
(N)	PJ14	Expansion Bus Connector	100
(O)	PJ16	FDD I/F Connector	26
(P)	PJ701	AC Adapter I/F Connector	6
(Q)	PJ702	Battery Pack I/F Connector	2
(R)	PJ703	Sub Battery I/F Connector	2
(S)	PJ704	System I/F Connector	6
(T)	PJ705	Power Supply I/F Connector	6

APPENDIX B PIN ASSIGNMENTS

B.1 PJ1 Expansion Memory I/F Connector

Table B-1 Expansion memory I/F connector pin assignment (40-pin)

Pin	Signal	I/O	Pin	Signal	I/O
1	GND		21	RAMV	O
2	D03;100	I/O	22	MA07;101	O
3	D04;100	I/O	23	MA06;101	O
4	D05;100	I/O	24	MA05;101	O
5	D06;100	I/O	25	MA04;101	O
6	D07;100	I/O	26	MA03;101	O
7	D08;100	I/O	27	MA02;101	O
8	D09;100	I/O	28	MA01;101	O
9	D10;100	I/O	29	DRMEN;100	I
10	MA08;101	O	30	GND	
11	GND		31	MA00;101	O
12	CASH;002	O	32	D00;100	I/O
13	RAS4;000	O	33	D01;100	I/O
14	RAS3;000	O	34	D02;100	I/O
15	MEMWE;002	O	35	D11;100	I/O
16	CASL;002	O	36	D12;100	I/O
17	RAS5;000	O	37	D13;100	I/O
18	RAS2;000	O	38	D14;100	I/O
19	EMA09;101	O	39	D15;100	I/O
20	RAMV		40	GND	

B.2 PJ2 PRT/FDD I/F Connector

Table B-2 PRT/FDD I/F connector pin assignment (25-pin)

[For Printer]

Pin	Signal	I/O	Pin	Signal	I/O
1	STROB;000	O	14	AUTOFD;000	O
2	PDB00;100	I/O	15	ERROR;000	I
3	PDB01;100	I/O	16	PINT;000	O
4	PDB02;100	I/O	17	SLIN;000	O
5	PDB03;100	I/O	18	GND	
6	PDB04;100	I/O	19	GND	
7	PDB05;100	I/O	20	GND	
8	PDB06;100	I/O	21	GND	
9	PDB07;100	I/O	22	GND	
10	ACK;000	I	23	GND	
11	BUSY;100	I	24	GND	
12	PE;100	I	25	GND	
13	SELECT;100	I	---	-----	---

Table B-2 PRT/FDD I/F connector pin assignment (25-pin) (continued)
[For FDD]

Pin	Signal	I/O	Pin	Signal	I/O
1	ERDY;001	I	14	ELOWD;000	O
2	EINDX;001	I	15	ESSEL;000	O
3	ETRO;001	I	16	EDIRC;000	O
4	EWPR;001	I	17	ESTEP;000	O
5	ERDAT;001	I	18	GND	
6	EDKCH;001	I	19	GND	
7	(N/C)		20	GND	
8	(N/C)		21	GND	
9	(N/C)		22	GND	
10	EDSL;000	O	23	GND	
11	EMON;000	O	24	GND	
12	EWDAT;000	O	25	GND	
13	EWEN;000	O	---	-----	---

B.3 PJ3 HDD I/F Connector (Left)

Table B-3 HDD I/F connector (L) pin assignment (22-pin)

Pin	Signal	I/O	Pin	Signal	I/O
1	RESET;020	O	12	HSD11;100	I/O
2	GND		13	HSD03;100	I/O
3	HSD07;100	I/O	14	HSD12;100	I/O
4	HSD08;100	I/O	15	HSD02;100	I/O
5	HSD06;100	I/O	16	GND	
6	GND		17	HSD13;100	I/O
7	HSD09;100	I/O	18	HSD01;100	I/O
8	HSD05;100	I/O	19	HSD14;100	I/O
9	HSD10;100	I/O	20	HSD00;100	I/O
10	HSD04;100	I/O	21	GND	
11	GND		22	GND	

B.4 PJ4 HDD I/F Connector (Right)

Table B-4 HDD I/F connector (R) pin assignment (22-pin)

Pin	Signal	I/O	Pin	Signal	I/O
1	GND		12	SA00;120	O
2	HSD15;100	I/O	13	GND	
3	VCC		14	SA02;120	O
4	IOWR;020	O	15	HDC0CS;020	O
5	GND		16	HDC1CS;020	O
6	IORD;020	O	17	GND	
7	IIRDY;100	I	18	DRVSL;000	I
8	IRQ14;100	I	19	VCC	
9	GND		20	VCC	
10	IIO16;000	I	21	ATSEL;100	I
11	SA01;120	O	22	GND	

B.5 PJ5 RS-232-C I/F Connector

Table B-5 RS-232-C I/F connector pin assignment (9-pin)

Pin	Signal	I/O	Pin	Signal	I/O
1	DCD;100	I	6	DSR;100	I
2	RD;000	I	7	RTS;100	O
3	SD;000	O	8	CTS;100	I
4	DTR;100	O	9	RI;100	I
5	GND		---	-----	---

B.6 PJ6 Numeric Keypad I/F Connector

Table B-6 Numeric keypad I/F connector pin assignment (3-pin)

Pin	Signal	I/O	Pin	Signal	I/O
1	GND		3	(N/C)	
2	TENKEY;100	O	---	-----	---

B.7 PJ7 Keyboard I/F Connector (Right)

Table B-7 Keyboard I/F connector (R) pin assignment (12-pin)

Pin	Signal	I/O	Pin	Signal	I/O
1	(N/C)		7	KBOT03;000	O
2	KBOT01;000	O	8	KBOT10;000	O
3	KBOT09;000	O	9	KBOT05;000	O
4	KBOT07;000	O	10	KBOT02;000	O
5	KBOT06;000	O	11	KBOT08;000	O
6	KBOT04;000	O	12	KBOT00;000	O

B.8 PJ8 Keyboard I/F Connector (Left)

Table B-8 Keyboard I/F connector (L) pin assignment (8-pin)

Pin	Signal	I/O	Pin	Signal	I/O
1	KBRT7;100	I	5	KBRT3;100	I
2	KBRT6;100	I	6	KBRT2;100	I
3	KBRT5;100	I	7	KBRT1;100	I
4	KBRT4;100	I	8	KBRT0;100	I

B.9 PJ9 LED Board I/F Connector

Table B-9 LED board I/F connector pin assignment (22-pin)

Pin	Signal	I/O	Pin	Signal	I/O
1	GND		12	CAPLED;000	O
2	BUV	O	13	GND	
3	BAT;100	O	14	OVRLED;000	O
4	GND		15	NUMLED;000	O
5	PNLOFF;001	O	16	CLED;000	O
6	VCC		17	GND	
7	VCC		18	ALED;000	O
8	DCIN;000	O	19	CRTLED;000	O
9	GND		20	LB;000	O
10	CKHRQ;000	O	21	CHG;000	O
11	POWER;000	O	22	GND	

B.10 PJ10 Built-in Modem I/F Connector

Table B-10 Built-in modem I/F connector pin assignment (30-pin)

Pin	Signal	I/O	Pin	Signal	I/O
1	N9V		16	GND	
2	BMDSL;000	O	17	SD02;100	I/O
3	\$14R7M;120	O	18	SD01;100	I/O
4	GND		19	GND	
5	SA00;100	O	20	GND	
6	SA01;100	O	21	SD00;100	I/O
7	SA02;100	O	22	IOWR;000	O
8	GND		23	IORD;000	O
9	SD07;100	I/O	24	VCC	
10	SD06;100	I/O	25	RESET;100	O
11	GND		26	BMPOF;100	O
12	GND		27	VCC	
13	SD05;100	I/O	28	VCC	
14	SD04;100	I/O	29	BMIRQ;000	I
15	SD03;100	I/O	30	BSPTON;000	O

B.11 PJ11 Speaker I/F Connector

Table B-11 Speaker I/F connector pin assignment (2-pin)

Pin	Signal	I/O	Pin	Signal	I/O
1	SPOUT0;100	I	2	SPOUT1;100	O

B.12 PJ12 LCD I/F Connector

Table B-12 LCD I/F connector pin assignment (30-pin)

Pin	Signal	I/O	Pin	Signal	I/O
1	GND		16	(N/C)	
2	LP;020	O	17	GND	
3	GND		18	SLD3;120	O
4	FP;020	O	19	GND	
5	GND		20	SLD2;120	O
6	SCLK;110	O	21	GND	
7	GND		22	SLD1;120	O
8	SUD3;120	O	23	GND	
9	GND		24	SLD0;120	O
10	SUD2;120	O	25	LCDV	
11	GND		26	GND	
12	SUD1;120	O	27	DSPV	
13	GND		28	GND	
14	SUD0;120	O	29	DSPV	
15	LCDV		30	GND	

B.13 PJ13 CRT I/F Connector

Table B-13 CRT I/F connector pin assignment (15-pin)

Pin	Signal	I/O	Pin	Signal	I/O
1	RED;100	O	9	(N/C)	
2	GREEN;100	O	10	GND	
3	BLUE;100	O	11	(N/C)	
4	(N/C)		12	(N/C)	
5	GND		13	PHSYNC;100	O
6	GND		14	PVSYNC;100	O
7	GND		15	(N/C)	
8	GND		---	-----	---

B.14 PJ14 Expansion Bus I/F Connector

Table B-14 Expansion bus I/F connector pin assignment (100-pin)

Pin	Signal	I/O	Pin	Signal	I/O
1	GND		51	GND	
2	RVCC		52	SVCC	
3	RGND		53	IOCLK;101	O
4	CPCNF;100	I	54	IRQ5;101	I
5	MDMSL;001	I/O	55	DRQ3;101	I
6	COMCLK;101	O	56	DACK3;001	O
7	MIRQ;001	I	57	AEN;101	O
8	SPKTON;001	I	58	DRQ1;101	I
9	GND		59	IOCRDY;101	I
10	SA00;101	O	60	GND	
11	SA01;101	O	61	IRQ10;101	I
12	SA02;101	O	62	IRQ14;101	I
13	SA03;101	O	63	SD08;101	I/O
14	SA04;101	O	64	SD09;101	I/O
15	SA05;101	O	65	IRQ11;101	I/O
16	SA06;101	O	66	SD10;101	I/O
17	SA07;101	O	67	SD11;101	I/O
18	GND		68	SD12;101	I/O
19	SA08;101	O	69	IRQ12;101	I
20	SA09;101	O	70	GND	
21	SA10;101	O	71	SD13;101	I/O
22	SA11;101	O	72	SD14;101	I/O
23	SA12;101	O	73	IRQ6;101	I
24	SA13;101	O	74	SD15;101	I/O
25	SA14;101	O	75	LA22;101	O
26	SA15;101	O	76	LA23;101	O
27	GND		77	DRQ2;101	I
28	SA16;101	O	78	LA21;101	O
29	SA17;101	O	79	LA19;101	O
30	SA18;101	O	80	LA20;101	O
31	SA19;101	O	81	DACK6;001	O
32	SD00;101	I/O	82	GND	
33	SD01;101	I/O	83	REFMD;001	O
34	SD02;101	I/O	84	LA18;101	O
35	SD03;101	I/O	85	MASTER;001	I
36	GND		86	LA17;101	O
37	SD04;101	I/O	87	SBHE;001	O
38	SD05;101	I/O	88	IOCHCK;001	I
39	SD06;101	I/O	89	MMCS16;001	I
40	SD07;101	I/O	90	GND	
41	SMEW;001	O	91	IOCS16;001	I
42	SMER;001	O	92	DACK2;001	O
43	GND		93	DRQ6;101	I
44	IOWR;001	I/O	94	DRQ5;101	I
45	IORD;001	I/O	95	DACK5;001	O
46	TC;101	O	96	MERD;001	I/O
47	BALE;101	O	97	IRQ4;101	I
48	RESET;101	O	98	MEWR;001	I/O
49	DACK1;001	O	99	IRQ7;101	I
50	IRQ9;101	I	100	GND	

B.15 PJ16 FDD I/F Connector

Table B-15 FDD I/F connector pin assignment (26-pin)

Pin	Signal	I/O	Pin	Signal	I/O
1	VCC	O	14	ISTEP;000	O
2	IINDX;000	I	15	GND	
3	VCC		16	IWDAT;000	O
4	IDSL;000	O	17	GND	
5	VCC		18	IWEN;000	O
6	DSKCHG;000	I	19	GND	
7	VCC		20	ITR0;000	I
8	IRDY;000	I	21	GND	
9	IHMED;000	I	22	IWPR;000	I
10	IMON;000	O	23	GND	
11	ILOWD;000	O	24	IRDAT;000	O
12	IDIRC;000	O	25	GND	
13	GND		26	ISSEL;000	O

B.16 PJ701 AC Adapter I/F Connector

Table B-16 AC adapter I/F connector pin assignment (6-pin)

Pin	Signal	I/O	Pin	Signal	I/O
1	INPUT1		4	ACHGON0	
2	INPUT2		5	GND	
3	GND		6	GND	

B.17 PJ702 Battery Pack I/F Connector

Table B-17 Battery pack I/F connector pin assignment (2-pin)

Pin	Signal	I/O	Pin	Signal	I/O
1	+14.4V		2	GND	

B.18 PJ703 Sub Battery I/F Connector

Table B-18 Sub battery pack I/F connector pin assignment (2-pin)

Pin	Signal	I/O	Pin	Signal	I/O
1	+6V		2	GND	

B.19 PJ704 System I/F Connector

Table B-19 System I/F connector pin assignment (6-pin)

Pin	Signal	I/O	Pin	Signal	I/O
1	PSVEE		4	PSVCC	
2	PSVDD		5	PSRAMV	
3	PSVCC		6	PSVDSP	

B.20 PJ705 Power Supply I/F Connector

Table B-20 Power supply I/F connector pin assignment (6-pin)

Pin	Signal	I/O	Pin	Signal	I/O
1	N9V		4	VCC	
2	P12V		5	RAMV	
3	VCC		6	DSPV	

APPENDIX C ASCII CHARACTER CODE

Table C-1 ASCII character code

HEXA DECIMAL VALUE	0	1	2	3	4	5	6	7	8	9	A	B	C	D	E	F
0	BLANK (NULL)	▶	BLANK SPACE	0	@	P	'	p	Ç	É	á	▤	▥	▦	α	≡
1	☺	◀	!	1	A	Q	a	q	ü	æ	í	▧	▨	▩	β	±
2	☹	↕	"	2	B	R	b	r	é	Æ	ó	▪	▫	▬	Γ	≥
3	♥	!!	#	3	C	S	c	s	â	ô	ú	▭	▮	▯	π	≤
4	♦	¶	\$	4	D	T	d	t	ä	ö	ñ	▰	▱	▲	Σ	∫
5	♣	§	%	5	E	U	e	u	à	ò	Ñ	△	▴	▵	σ	∫
6	♠	■	&	6	F	V	f	v	å	û	ä	▴	▵	▶	μ	÷
7	•	↕	'	7	G	W	g	w	ç	ù	ö	▶	▷	▸	τ	≈
8	●	↑	(8	H	X	h	x	ê	ÿ	ï	▸	▹	►	ϕ	°
9	○	↓)	9	I	Y	i	y	ë	Ö	Γ	▸	▹	►	θ	•
A	◉	→	*	:	J	Z	j	z	è	Ü	▸	▹	►	▻	Ω	•
B	♂	←	+	;	K	[k	{	ï	ç	½	▸	▹	►	δ	√
C	♀	└	,	<	L	\	l		î	£	¼	▸	▹	►	∞	∞
D	♪	↔	-	=	M]	m	}	ì	¥	ı	▸	▹	►	φ	2
E	♫	▲	.	>	N	^	n	~	Ä	Pt	ø	▸	▹	►	€	■
F	⚙	▼	/	?	O	_	o	Δ	Å	ƒ	»	▸	▹	►	∩	BLANK FF

This page intentionally left blank

APPENDIX D KEYBOARD SCAN/ CHARACTER CODE

Table D-1 Keyboard scan/character code

Cap No.	Key Top	Lower Case	Upper Case	Caps Lock		With (Ctrl)	With (Alt)
				Lower	Upper		
1	~ `	29 60	29 7E	29 60	29 7E	-	*29 00
2	!	02 31	02 21	02 31	02 21	-	78 00
3	@ 1 2	03 32	03 40	03 32	03 40	03 00	79 00
4	# 3	04 33	04 23	04 33	04 23	-	7A 00
5	\$ 4	05 34	05 24	05 34	05 24	-	7B 00
6	% 5	06 35	06 25	06 35	06 25	-	7C 00
7	^ 6	07 36	07 5E	07 36	07 5E	07 1E	7D 00
8	& 7	08 37	08 26	08 37	08 26	-	7E 00
9	* 8	09 38	09 2A	09 38	09 2A	-	7F 00
10	(9	0A 39	0A 28	0A 39	0A 28	-	80 00
11) 0	0B 30	0B 29	0B 30	0B 29	-	81 00
12	_	0C 2D	0C 5F	0C 2D	0C 5F	0C 1F	82 00
13	+ =	0D 3D	0D 2B	0D 3D	0D 2B	-	83 00
15	Back space	0E 08	0E 08	0E 08	0E 08	0E 7F	*0E 00
16	Tab	0F 09	0F 00	0F 09	0F 00	*94 00	*A5 00
17	Q	10 71	10 51	10 71	10 51	10 11	10 00
18	W	11 77	11 57	11 77	11 57	11 17	11 00
19	E	12 65	12 45	12 65	12 45	12 05	12 00
20	R	13 72	13 52	13 72	13 52	13 12	13 00
21	T	14 74	14 54	14 74	14 54	14 14	14 00
22	Y	15 79	15 59	15 79	15 59	15 19	15 00
23	U	16 75	16 55	16 75	16 55	16 15	16 00
24	I	17 69	17 49	17 69	17 49	17 09	17 00

NOTE: *= Only extended code

Table D-1 Keyboard scan/character code (continued)

Cap No.	Key Top	Lower Case	Upper Case	Caps Lock		With (Ctrl)	With (Alt)
				Lower	Upper		
25	O	18 6F	18 4F	18 6F	18 4F	18 0F	18 00
26	P	19 70	19 50	19 70	19 50	19 10	19 00
27	{	1A 5B	1A 7B	1A 5B	1A 7B	1A 1B	*1A 00
28	}	1B 5D	1B 7D	1B 5D	1B 7D	1B 1D	*1B 00
29		2B 5C	2B 7C	2B 5C	2B 7C	2B 1C	*2B 00
30	Caps Lock	-	-	-	-	-	-
31	A	1E 61	1E 41	1E 61	1E 41	1E 01	1E 00
32	S	1F 73	1F 53	1F 73	1F 53	1F 13	1F 00
33	D	20 64	20 44	20 64	20 44	20 04	20 00
34	F	21 66	21 46	21 66	21 46	21 06	21 00
35	G	22 67	22 47	22 67	22 47	22 07	22 00
36	H	23 68	23 48	23 68	23 48	23 08	23 00
37	J	24 6A	24 4A	24 6A	24 4A	24 0A	24 00
38	K	25 6B	25 4B	25 6B	25 4B	25 0B	25 00
39	L	26 6C	26 4C	26 6C	26 4C	26 0C	26 00
40	:	27 3B	27 3A	27 3B	27 3A	-	*27 00
41	"	28 27	28 22	28 27	28 22	-	*28 00
43	Enter	1C 0D	1C 0D	1C 0D	1C 0D	1C 0A	*1C 00
44	Shift (L)	-	-	-	-	-	-
46	Z	2C 7A	2C 5A	2C 7A	2C 5A	2C 1A	2C 00
47	X	2D 78	2D 58	2D 78	2D 58	2D 18	2D 00
48	C	2E 63	2E 43	2E 63	2E 43	2E 03	2E 00
49	V	2F 76	2F 56	2F 76	2F 56	2F 16	2F 00
50	B	30 62	30 42	30 62	30 42	30 02	30 00
51	N	31 6E	31 4E	31 6E	31 4E	31 0E	31 00

NOTE: *= Only extended code

Table D-1 Keyboard scan/character code (continued)

Cap No.	Key Top	Lower Case	Upper Case	Caps Lock		With (Ctrl)	With (Alt)
				Lower	Upper		
52	M	32 6D	32 4D	32 6D	32 4D	32 0D	32 00
53	<	33 2C	33 3C	33 2C	33 3C	-	*33 00
54	>	34 2E	34 3E	34 2E	34 3E	-	*34 00
55	? /	35 2F	35 3F	35 2F	35 3F	-	*35 00
57	Shift (R)	-	-	-	-	-	-
58	Ctrl (L)	-	-	-	-	-	-
60	Alt (L)	-	-	-	-	-	-
61	Space	39 20	39 20	39 20	39 20	39 20	39 20
62	AltGr	-	-	-	-	-	-
75	Ins	52 00 52 E0	52 00 52 E0	52 00 52 E0	52 00 52 E0	*92 E0	*A2 00
76	Del	53 00 53 E0	53 00 53 E0	53 00 53 E0	53 00 53 E0	*93 E0	*A3 00
79	←	4B 00 4B E0	4B 00 4B E0	4B 00 4B E0	4B 00 4B E0	73 00 73 E0	*9B 00
80	Home	47 00 47 E0	47 00 47 E0	47 00 47 E0	47 00 47 E0	77 00 77 E0	*97 00
81	End	4F 00 4F E0	4F 00 4F E0	4F 00 4F E0	4F 00 4F E0	75 00 75 E0	*9F 00
83	↑	48 00 48 E0	48 00 48 E0	48 00 48 E0	48 00 48 E0	*8D E0	*98 00
84	↓	50 00 50 E0	50 00 50 E0	50 00 50 E0	50 00 50 E0	*91 E0	*A0 00
85	PgUp	49 00 49 E0	49 00 49 E0	49 00 49 E0	49 00 49 E0	84 00 *84 E0	*99 00
86	PgDn	51 00 51 E0	51 00 51 E0	51 00 51 E0	51 00 51 E0	76 00 76 E0	*A1 00
89	→	4D 00 4D E0	4D 00 4D E0	4D 00 4D E0	4D 00 4D E0	74 00 74 E0	*9D 00
90	Num Lock	-	-	-	-	-	-
105	+	4A 2D	4A 2D	4A 2D	4A 2D	*8E 00	*4A 00
106	-	4E 2B	4E 2B	4E 2B	4E 2B	*90 00	*4E 00
110	Esc	01 1B	01 1B	01 1B	01 1B	01 1B	*01 00
112	F1	3B 00	54 00	3B 00	54 00	5E 00	68 00
113	F2	3C 00	55 00	3C 00	55 00	5F 00	69 00

NOTE: *= Only extended code

Table D-1 Keyboard scan/character code (continued)

Cap No.	Key Top	Lower Case	Upper Case	Caps Lock		With (Ctrl)	With (Alt)
				Lower	Upper		
114	F3	3D 00	56 00	3D 00	56 00	60 00	6A 00
115	F4	3E 00	57 00	3E 00	57 00	61 00	6B 00
116	F5	3F 00	58 00	3F 00	58 00	62 00	6C 00
117	F6	40 00	59 00	40 00	59 00	63 00	6D 00
118	F7	41 00	5A 00	41 00	5A 00	64 00	6E 00
119	F8	42 00	5B 00	42 00	5B 00	65 00	6F 00
120	F9	43 00	5C 00	43 00	5C 00	66 00	70 00
121	F10	44 00	5D 00	44 00	5D 00	67 00	71 00
122	F11	*85 00	*87 00	*85 00	*87 00	*89 00	*8B 00
123	F12	*86 00	*88 00	*86 00	*88 00	*8A 00	*8C 00
125	Scrol Lock	-	-	-	-	-	-
200	Pause Break	-	-	-	-	-	-
201	PrtSc SysRq	-	-	-	-	*37 00	-
202	Fn	-	-	-	-	-	-

NOTE: *= Only extended code

APPENDIX E KEYBOARD LAYOUTS

E.1 USA keyboard

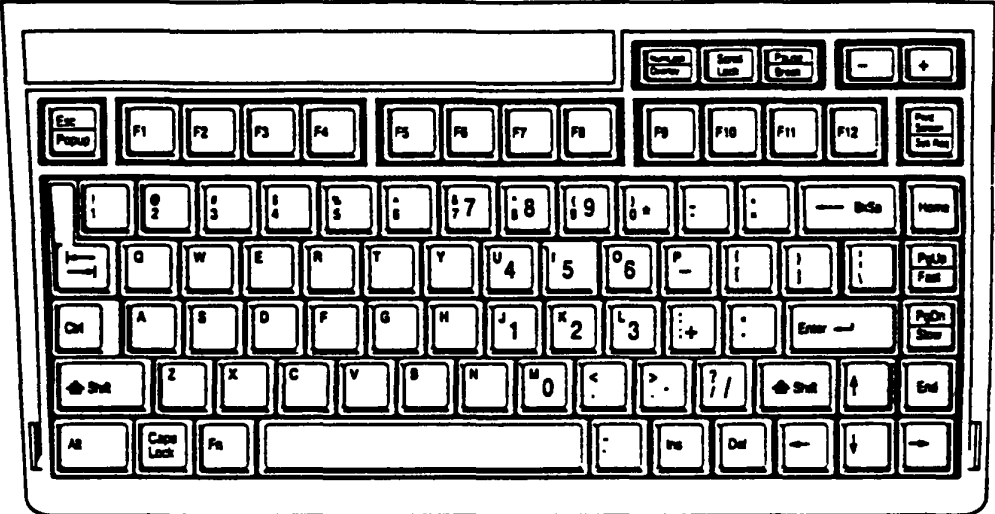

Figure E-1 USA keyboard

E.2 UK keyboard

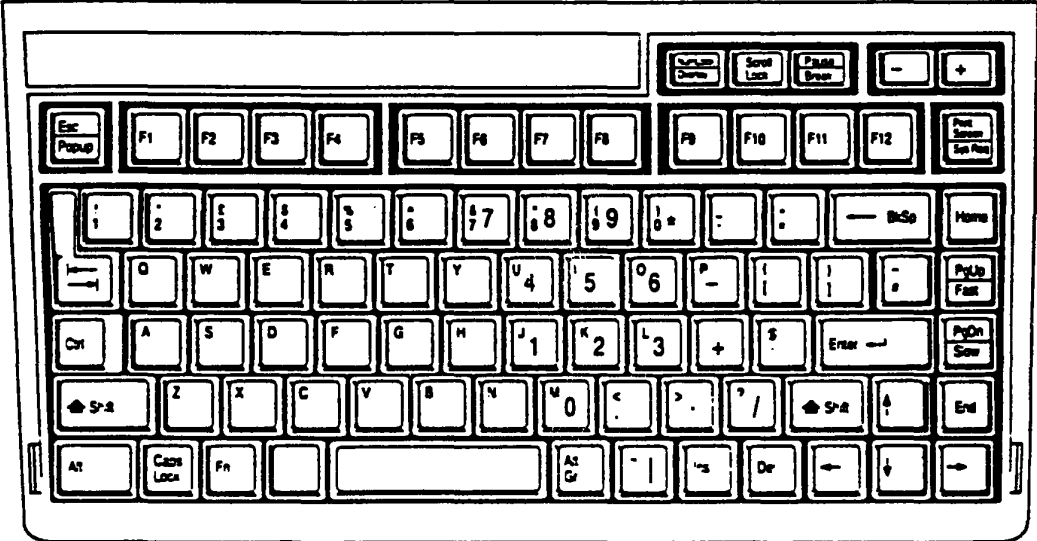

Figure E-2 UK keyboard

E.3 German keyboard

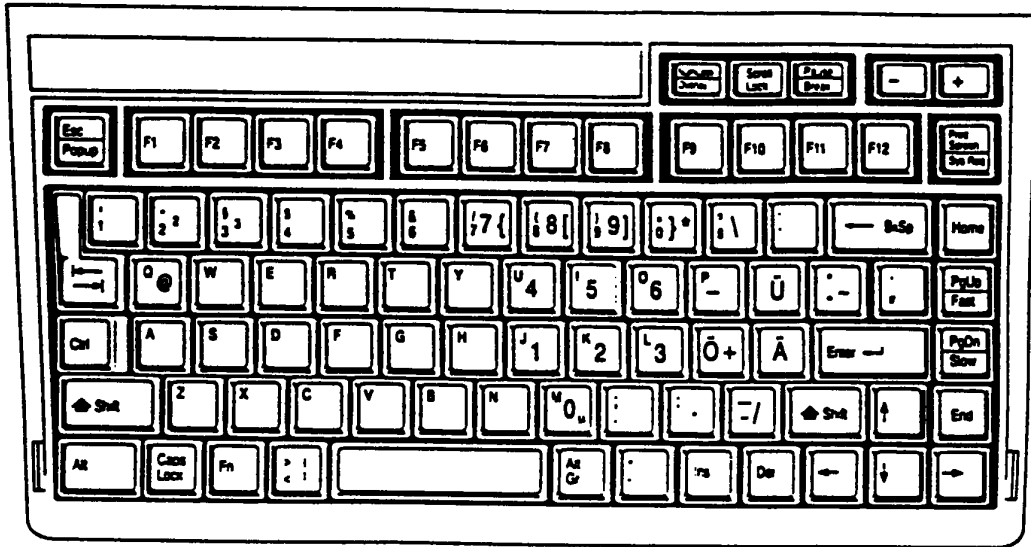

Figure E-3 German keyboard

E.4 French keyboard

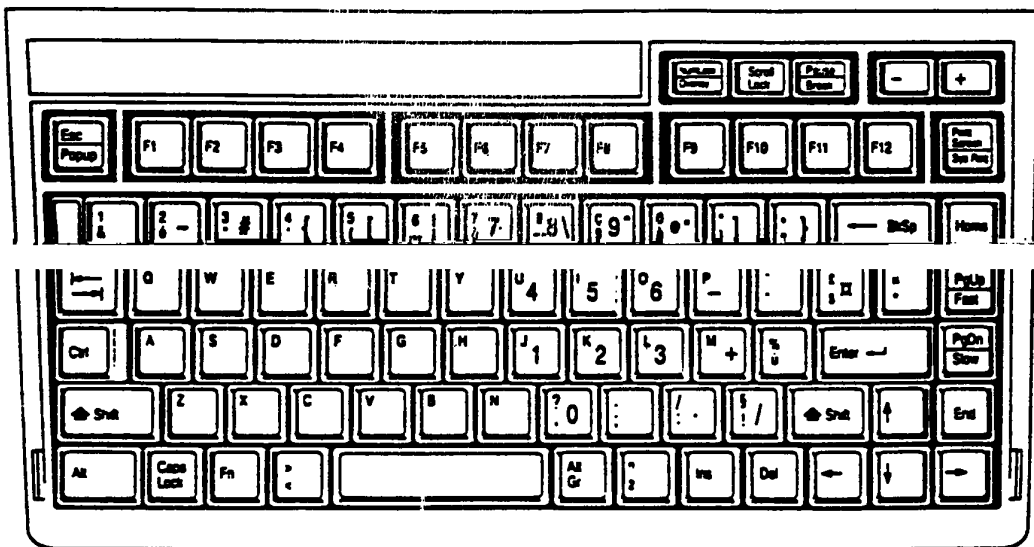

Figure E-4 French keyboard

E.5 Spanish keyboard

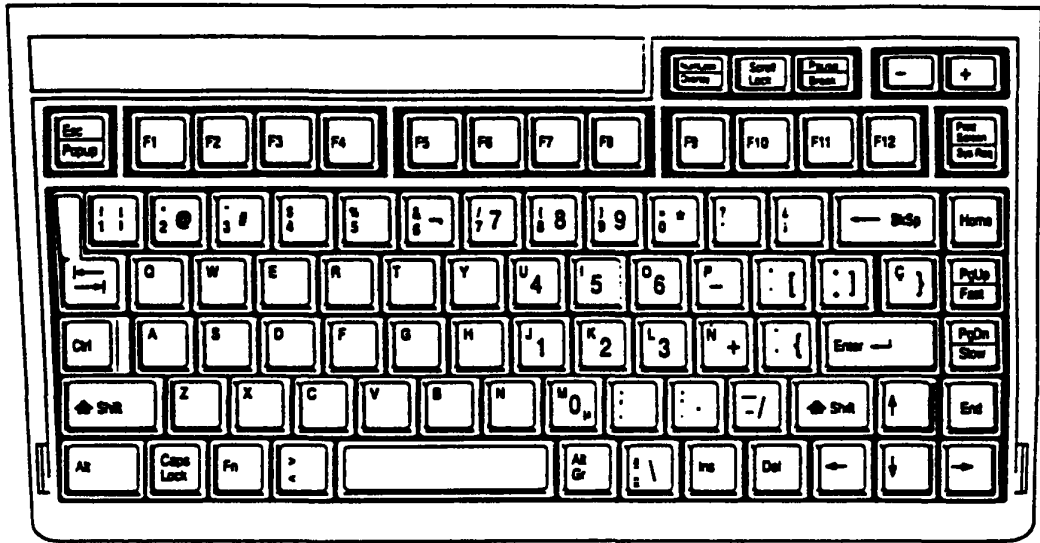

Figure E-5 Spanish keyboard

E.6 Italian keyboard

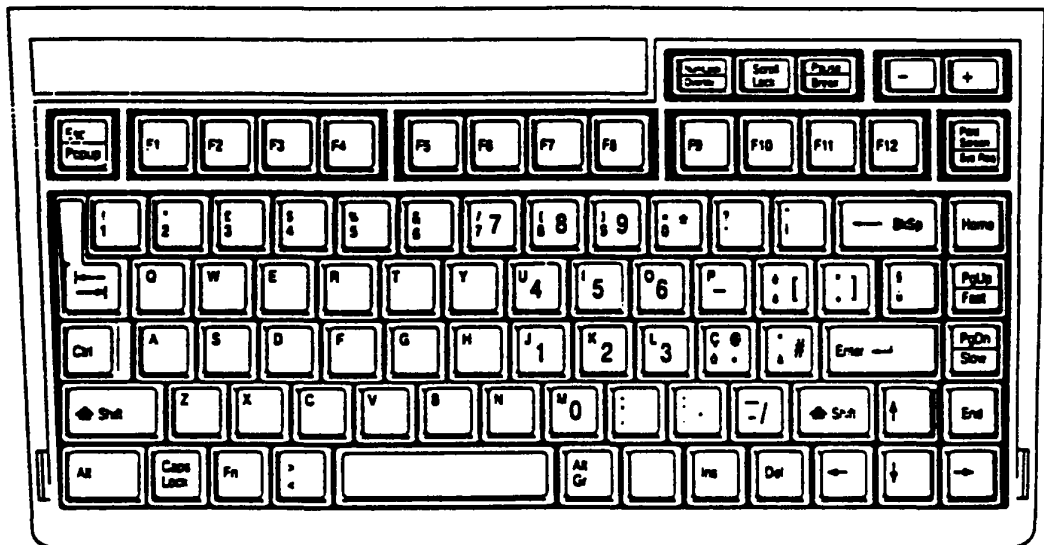

Figure E-6 Italian keyboard

E.7 Swedish/Finnish keyboard

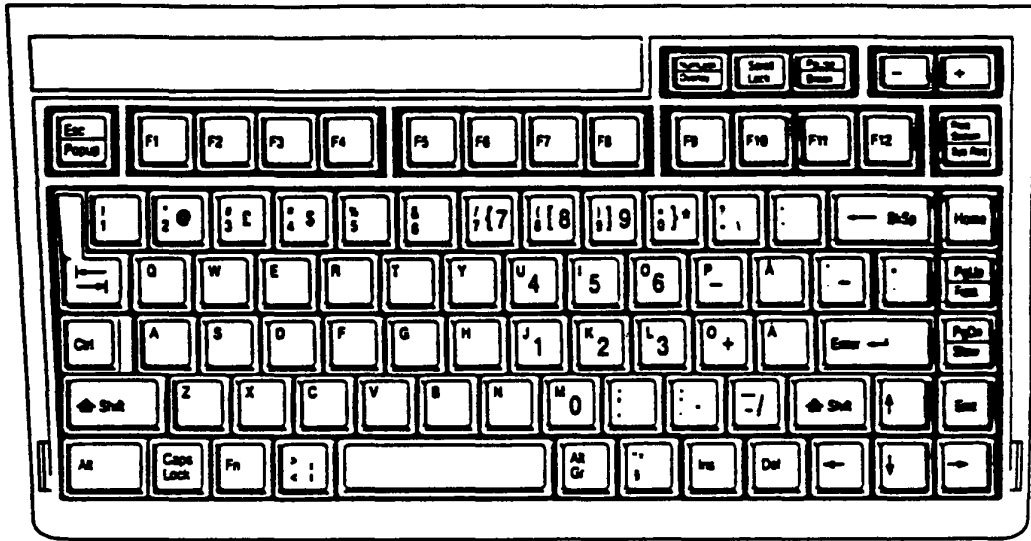

Figure E-7 Swedish/Finnish keyboard

E.8 Danish keyboard

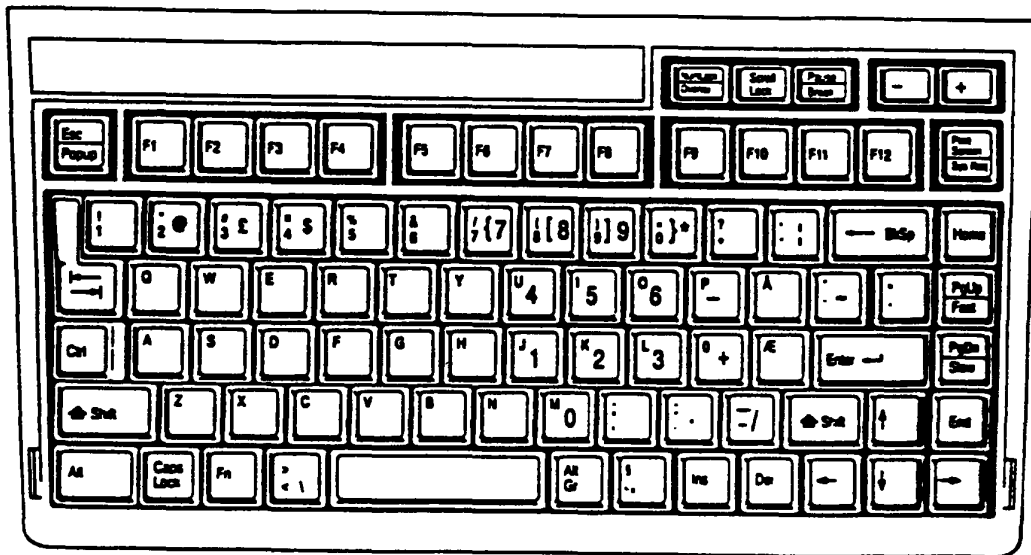

Figure E-8 Danish keyboard

E.9 Norwegian keyboard

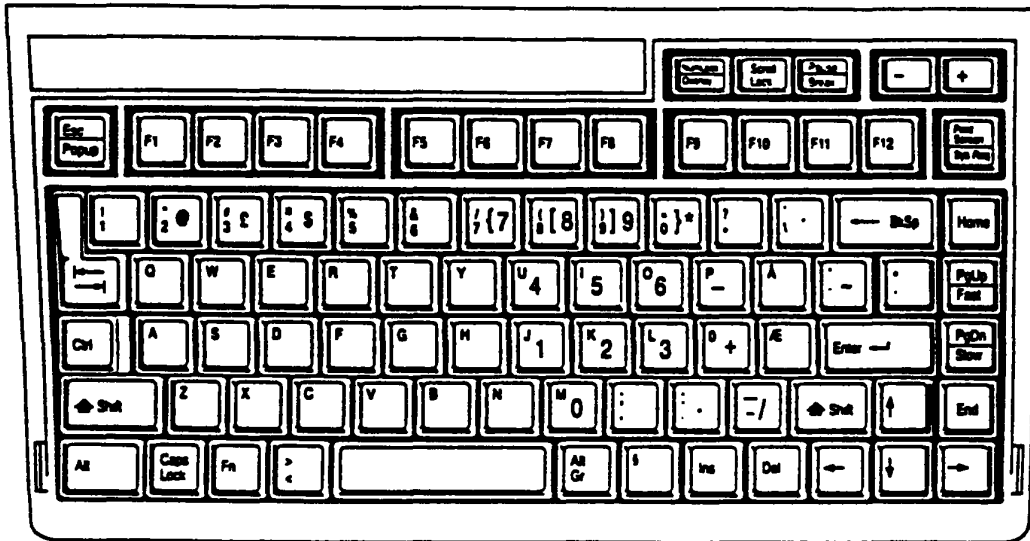

Figure E-9 Norwegian keyboard

E.10 Swiss (French/German) keyboard

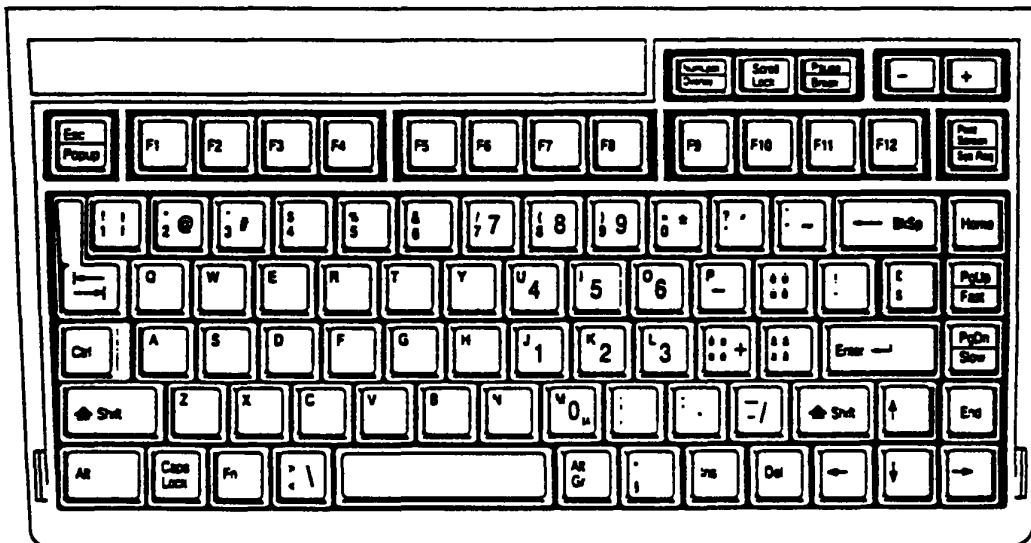

Figure E-10 Swiss (French/German) keyboard

E.11 Canadian keyboard

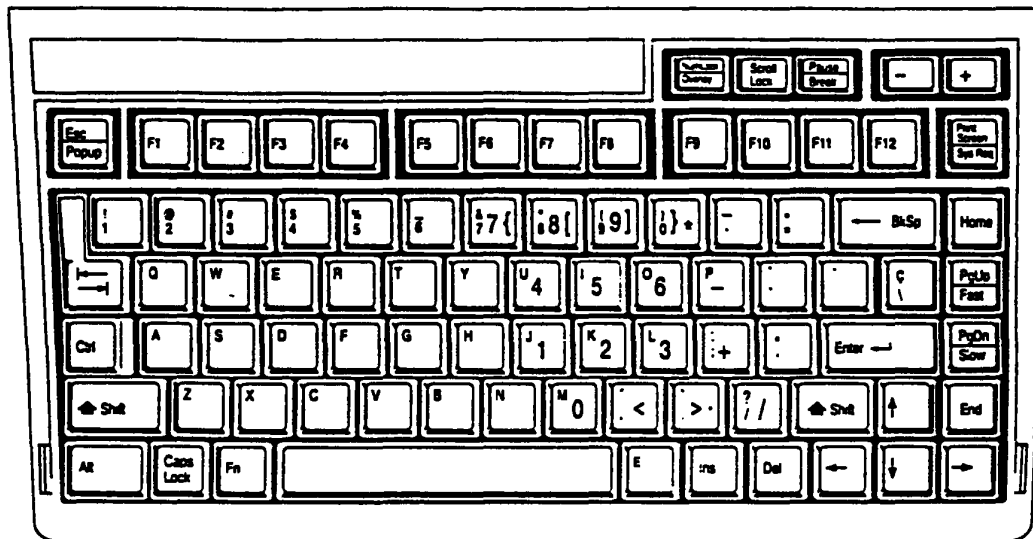

Figure E-11 Canadian keyboard

E.12 Keycap number

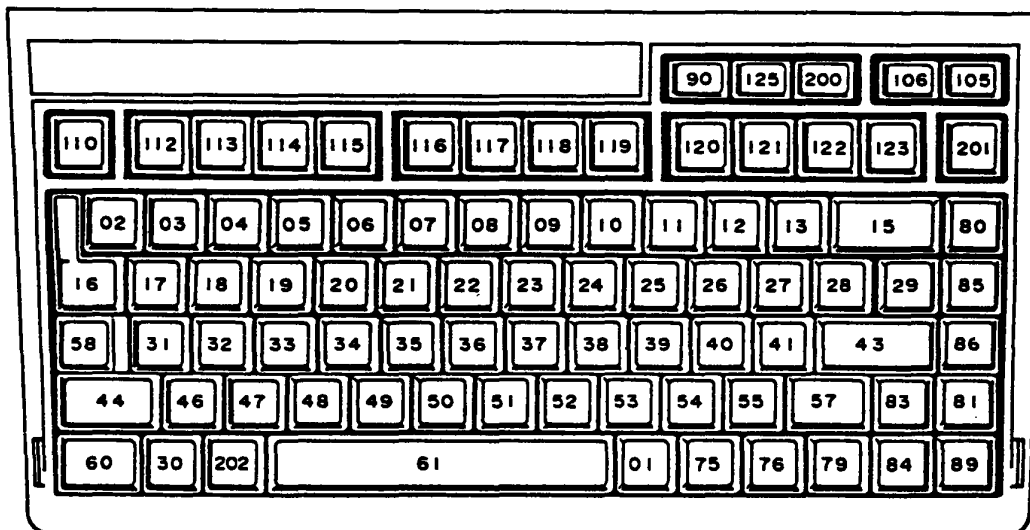

Figure E-12 Keycap number