

**Panasonic**

# Operating Instructions

Impact Dot Matrix Printer

## KX-P3626

*Quiet*

*Printing*

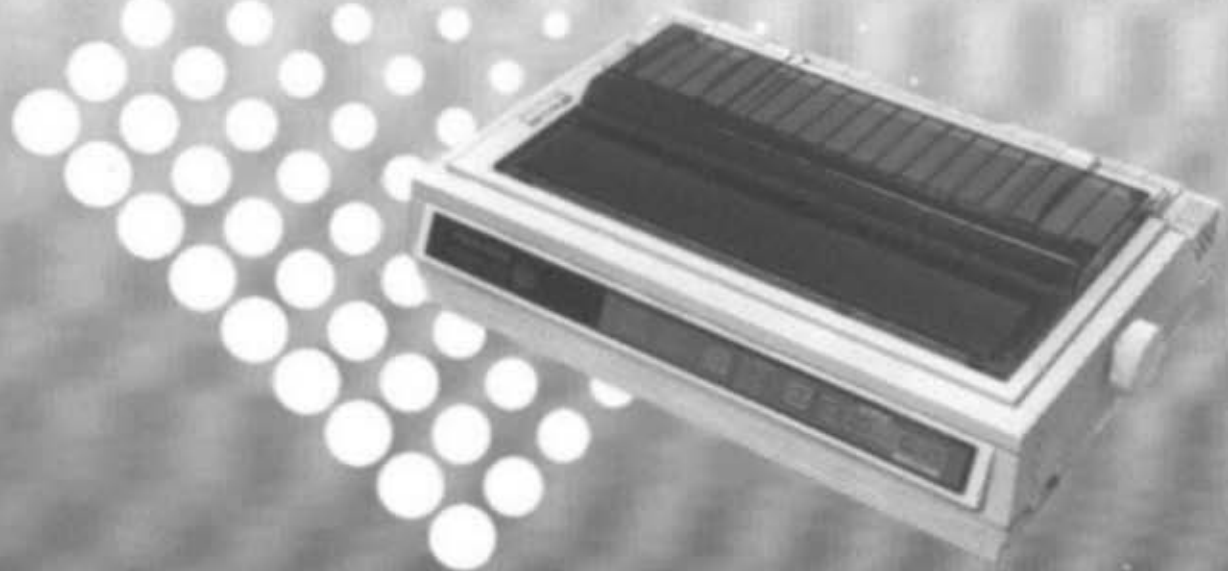

Before operating this unit, please read these instructions completely.

## FOR USE IN THE UNITED STATES ONLY

This equipment has been tested and found to comply with the limits for a Class B digital device, pursuant to Part 15 of FCC Rules. These limits are designed to provide reasonable protection against harmful interference in a residential installation.

This equipment generates, uses and can radiate radio frequency energy and, if not installed and used in accordance with the instructions, may cause harmful interference to radio communications. However, there is no guarantee that interference will not occur in a particular installation. If this equipment does cause harmful interference to radio or television reception, which can be determined by turning the equipment off and on, the user is encouraged to try to correct the interference by one or more of the following measures:

- Reorient or relocate the receiving antenna.
- Increase the separation between the equipment and receiver.
- Connect the equipment into an outlet on a circuit different from that to which the receiver is connected.
- Consult the dealer or an experienced radio/TV technician for help.

The user may find the booklet "Something About Interference" available from FCC local regional offices helpful.

**FCC Warning:** To assure continued FCC emission limit compliance, the user must use only the recommended shield interfacing cable when connecting to a host computer. Also, any unauthorized changes or modifications to this equipments would void the users authority to operate this device.

## WARNING

- The power source voltage of this unit is listed on the nameplate. Plug the printer only into an outlet with the proper voltage.
- To prevent fire or shock hazard, do not expose this product to rain or any type of moisture.
- When you operate this equipment, the outlet should be near the equipment and should be easily accessible.

The serial number of the unit may be found on the label on the rear of the unit. For your convenience, note this number below, and retain this book, along with your proof of purchase, to serve as a permanent record of your purchase in the event of a theft, or for future reference.

MODEL NO.   KX-P3626   NAME OF DEALER \_\_\_\_\_

SERIAL NO. \_\_\_\_\_ DATE OF PURCHASE \_\_\_\_\_

IBM and IBM-PC are trademarks of International Business Machines Corporation.

Proprinter is a trademark of International Business Machines Corporation.

Microsoft and Windows are trademarks of Microsoft Corporation.

Epson is a trademark of Seiko Epson Corporation.

Epson ESC/P2 is a trademark of Seiko Epson Corporation.

Any details given in these Operating Instructions are subject to change without notice.

All Rights Reserved. © COPYRIGHT 1994 KYUSHU MATSUSHITA ELECTRIC CO., LTD.

# Table of Contents

4	Introduction	4	Features
<b>Chap. 1 Before You Start</b>			
5	<b>Cautions</b>	6	<b>Unpacking</b>
5	Operating Environment	7	Preparation
5	Precautions	9	<b>Parts of the Printer</b>
<b>Chap. 2 Setup</b>			
11	<b>Connecting to a Computer</b>	19	Fanfold Paper (Bottom,Front Feed/Pull Tractor Mode)
12	<b>Ribbon Cassette</b>	23	Single Sheets and Envelopes (Top Feed/Friction Mode)
12	Installing the Ribbon Cassette	25	<b>Self Test</b>
14	Removing the Ribbon Cassette	26	<b>Printer Driver Selection</b>
15	<b>Paper Feed Selection</b>	27	<b>Installing a Printer Driver (Windows Ver. 3.1)</b>
16	<b>Installing Paper</b>		
16	Fanfold Paper (Rear Feed/Push Tractor Mode)		
<b>Chap. 3 Using the Setup Disk</b>			
28	<b>Initial Setup Mode</b>	36	Save to Disk
32	Running the Initial Setup Program	37	Load from Disk (Recall Settings)
33	Exiting the Initial Setup Program	38	Send to Printer
34	Print Settings	38	Resetting to Factory Setting
34	Display Setting List	39	Help
35	Setting Selections on Setup Disk		
<b>Chap. 4 Using the Control Panel</b>			
40	<b>Using the Control Panel</b>	43	Top of Form Function (TOF SET)
40	Selecting a Character Font	44	Tear Off <b>TEAR OFF</b>
40	Selecting a Character Pitch	45	Paper Parking <b>LOAD/PARK</b>
41	Super Quiet Mode	46	Paper Out Detector
42	Line Feed/Form Feed <b>LF/FF</b>	47	Initial Setup Mode
<b>Chap. 5 Software Commands</b>			
52	Command Reference Program (Using the Setup Disk)		
<b>Chap. 6 Maintenance &amp; Troubleshooting</b>			
55	<b>Periodic Maintenance/ Troubleshooting</b>	55	Periodic Maintenance Troubleshooting
<b>Appendix</b>			
57	<b>Initialization/Hex Dump</b>	62	<b>Interfacing</b>
57	Initialization/Hex Dump	62	Parallel Interfacing
58	<b>Printer Specifications</b>	64	<b>Character Set Tables</b>
60	<b>Paper Specifications</b>	70	<b>Glossary</b>
60	Fanfold Paper/Single Sheet/ Envelope	73	<b>Index</b>
61	Printing Area	75	<b>Options and Supplies</b>

Chap. 1

Chap. 2

Chap. 3

Chap. 4

Chap. 5

Chap. 6

Appendix

# Introduction

---

**Congratulations on purchasing a Panasonic printer.**

This printer is a versatile, high quality 24-pin dot matrix printer which is designed to meet the needs of your office.

This printer has been factory set to operate with most of the popular software packages. Your application software should control the printer functions. In most cases, there will be no need to change the initial printer settings.

## Features

- Printer Emulation:** Epson LQ-1170 and IBM Proprinter XL24E
- Setup Disk:** Setup program, Command Reference program and a Printer Driver for Windows Ver. 3.1
- Super Quiet Mode:** Reduces printing noise
- Fonts:** 3 Draft (Pica, Elite, Micron)  
7 Letter Quality (Courier, Bold PS, Prestige, Script, Sans Serif, Roman, OCR-B)  
1 Super Letter Quality (Roman)  
6 Scalable Fonts (Courier, Bold PS, Prestige, Script, Sans Serif, Roman)
- Printing Speed:** Draft — 300 characters per second (15 cpi)  
LQ — 100 characters per second (15 cpi)  
SLQ — 40 characters per second (12 cpi)
- Paper Handling:** Friction and Tractor (Push/Pull built-in)
- Paper Paths:** Rear, Bottom, Front, Top
- Tear Off:** Advances fanfold paper's perforation to tear position
- Paper Parking:** Allows single sheets/envelopes to be used without removing/wasting fanfold paper
- Cut Sheet Feeder Option (KX-P38):** Provides fast and automatic feeding of single sheets
- Serial Interface Option (KX-PS13 and KX-PS14):** You may select parallel or serial when the KX-PS14 serial interface board is installed
- Copies:** Original plus four non-carbon copies

# Cautions

## Operating Environment

- Do not use the printer in the following conditions.

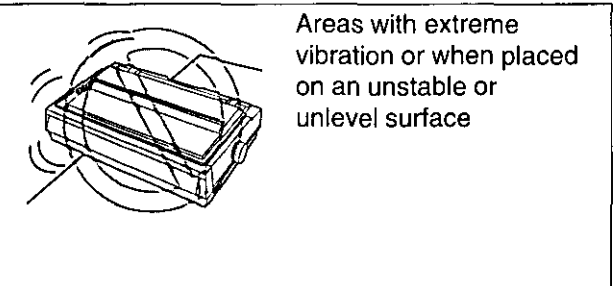
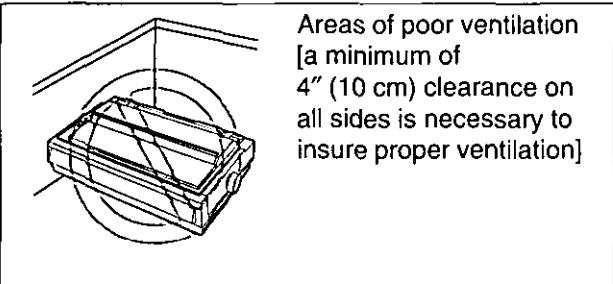
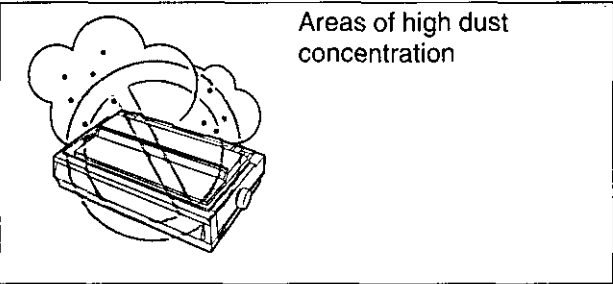
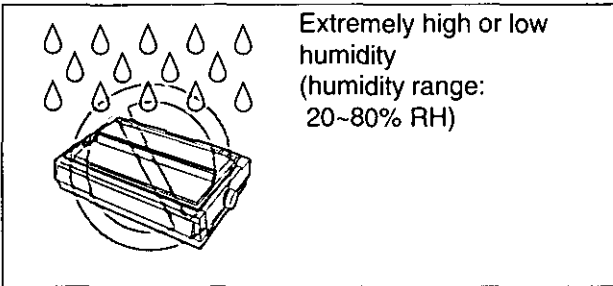
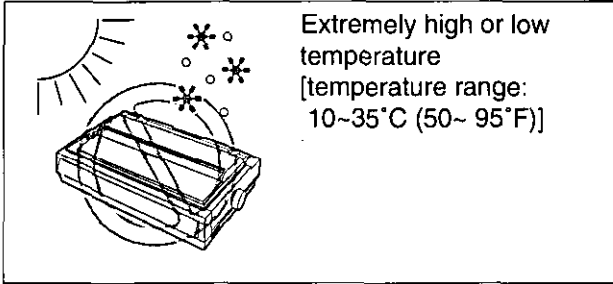

## Precautions

The following precautions are recommended to extend the life of the printer.

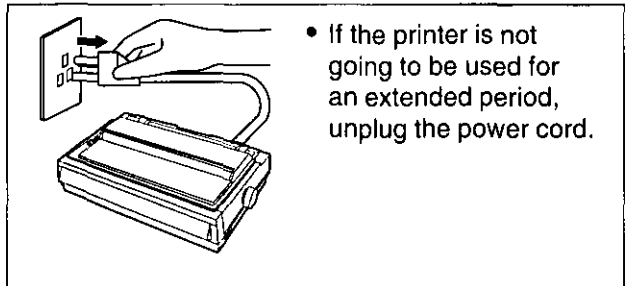
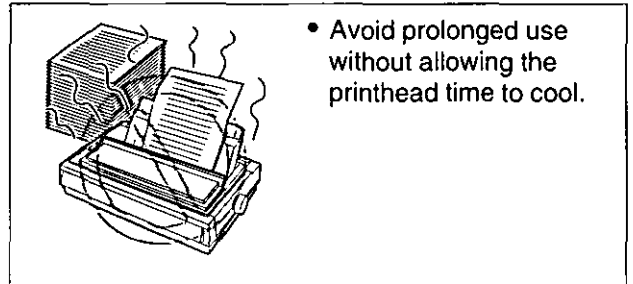
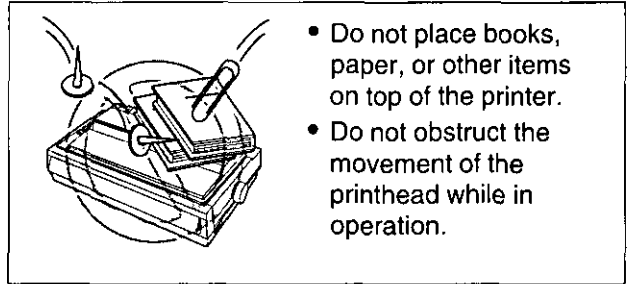
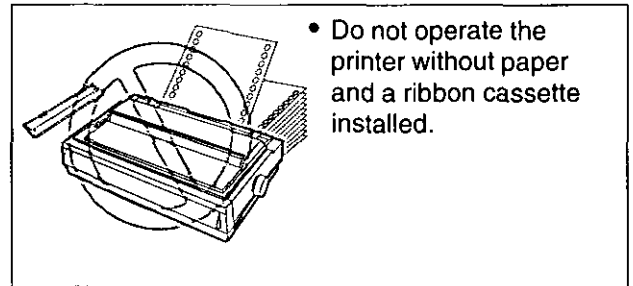
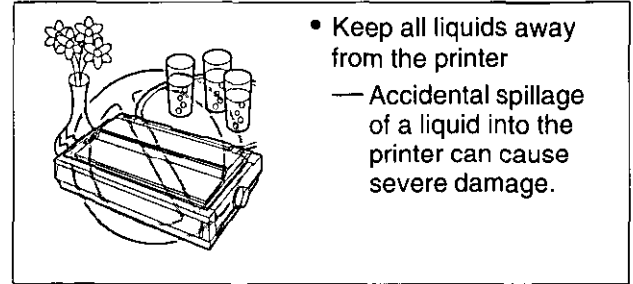

# Unpacking

Having unpacked the printer, make sure none of the contents shown below are missing or damaged. Report damages or shortages to the store from which the unit was purchased.

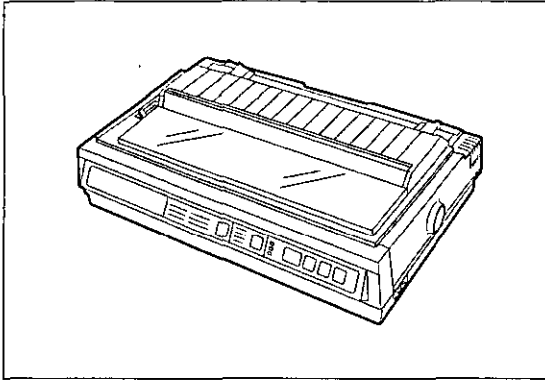

**Printer**

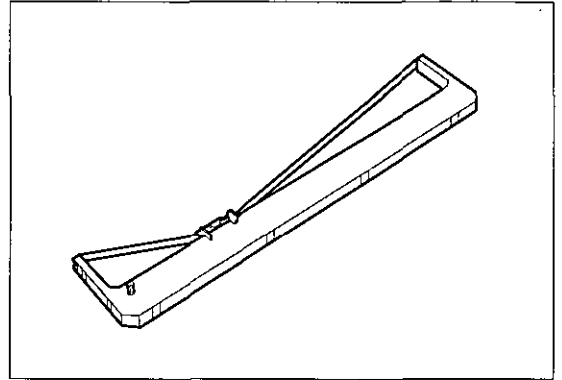

**Ribbon cassette (KX-P170)**

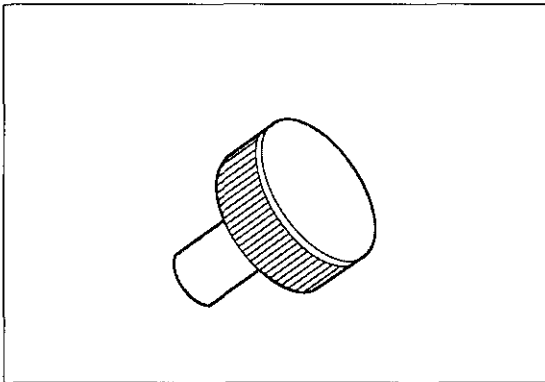

**Platen knob**

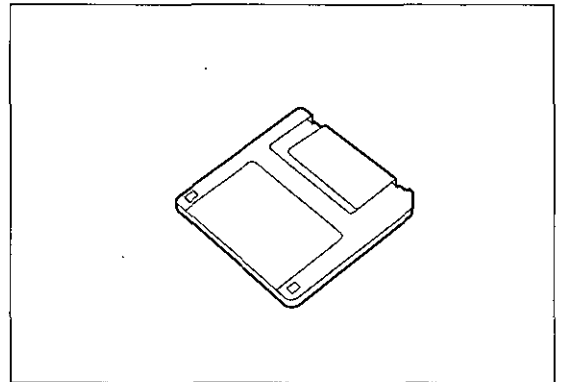

**Setup Disk**

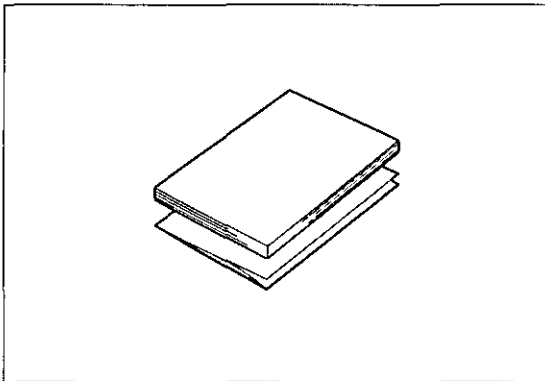

**Operating manual  
Quick start guide**

- The Setup Disk contains a Printer Driver for Windows Ver. 3.1 ( P. 27), a Setup program ( P. 28) and a Command Reference program ( P. 52).
- To use this Setup Disk, you need to have an IBM-PC or a compatible computer with a 3.5" floppy disk drive.

**Note:**

- It is recommended that you save the original carton and packing materials for proper shipping and transporting of the printer.

## Preparation

- (a) Insert the platen knob into the hole on the right side of the printer and rotate it slowly until it slips onto the shaft. Push the platen knob onto the platen shaft to secure.

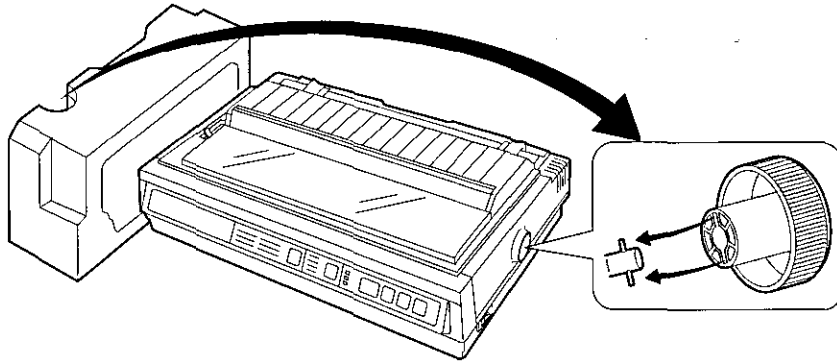

- (b) **1** Fold forward the smoked plastic cover.  
**2** Remove the protective paper which includes unpacking instructions.  
**3** Raise the smoked plastic cover and remove it.

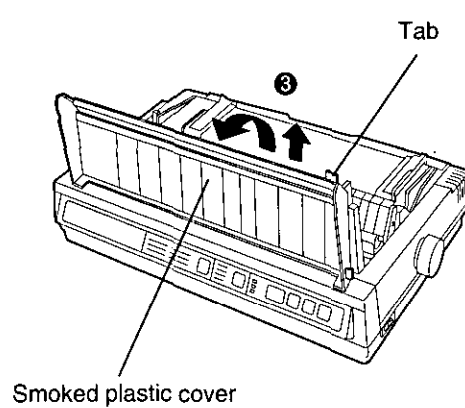
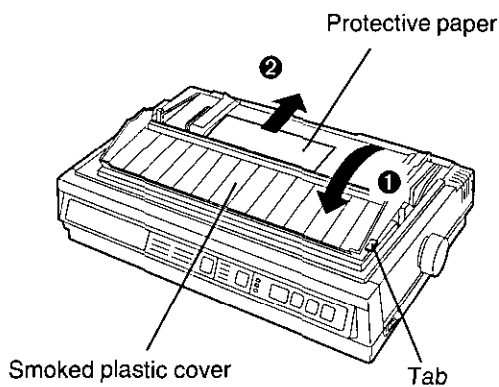

**Note:**

- Be careful not to drop the smoked plastic cover.

(c) Remove the carriage stopper band, as shown.

Carriage stopper band

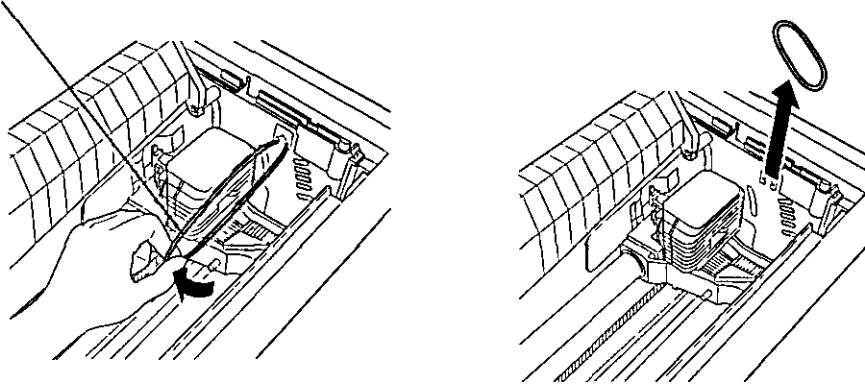

(d) Remove the separator pad lifting the paper easel by holding the tab of it

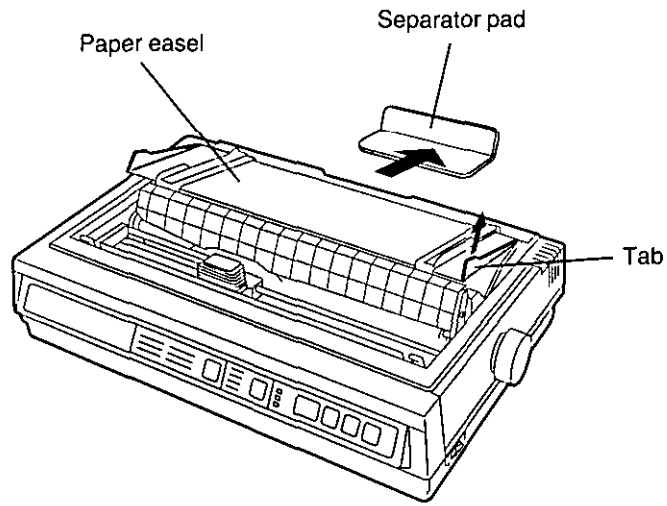

**Note:**

- Be sure to replace the carriage stopper band and the separator pad before transporting the printer



# Parts of the Printer

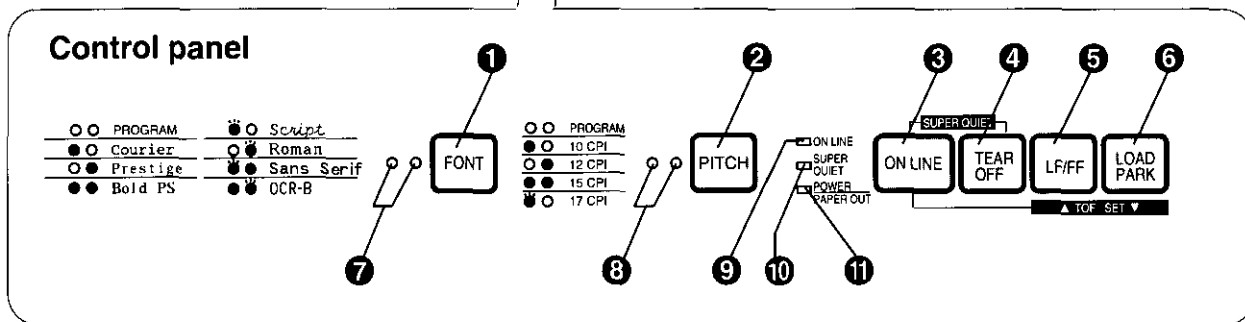
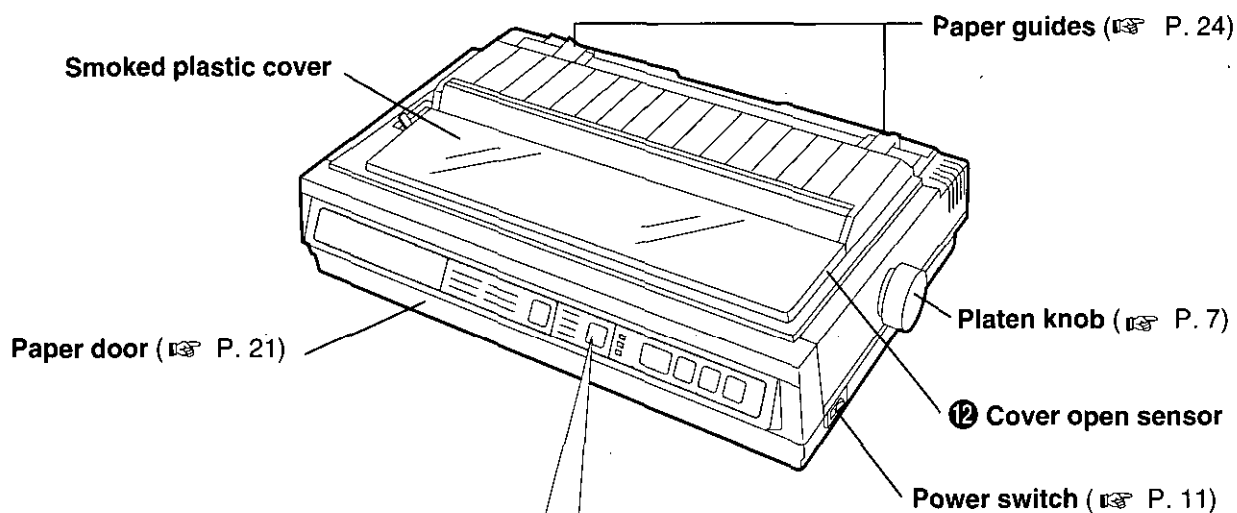

- 1 FONT switch**  
Pressing this switch selects the font style. ( P. 40)
- 2 PITCH switch**  
Pressing this switch selects the characters per inch (cpi). ( P. 40)
- 3 ON LINE switch**  
This switch opens and closes the communication line with the computer.
- 4 TEAR OFF switch**  
Pressing this switch advances or reverses the paper for tearing off. ( P. 44)
- 5 LF/FF switch**  
Pressing this switch advances the paper one line at a time. Holding this switch advances the paper to the first print line of the next page. ( P. 42)
- 6 LOAD/PARK switch**  
Pressing this switch loads or parks the paper. ( P. 45)
- 7 FONT indicators**  
These indicators identify which Font has been selected. ( P. 40)
- 8 PITCH indicators**  
These indicators identify what Pitch (CPI) has been selected. ( P. 40)
- 9 ON LINE indicator**  
This indicator is lit when the printer is in the ON LINE mode, and is not lit when in the OFF LINE mode.
- 10 SUPER QUIET indicator**  
This indicator is lit when the printer is in the SUPER QUIET mode. (While pressing the ON LINE switch, press the **TEAR/OFF** switch.) ( P. 41)
- 11 POWER/PAPER OUT indicator**  
This indicator is lit when the power is on and paper is installed. It blinks when paper is not installed. ( P. 46)
- 12 Cover open sensor**  
When the cover is opened, the machine will beep and printing will stop. To resume printing close cover and press **ON LINE**.

# Parts of the Printer

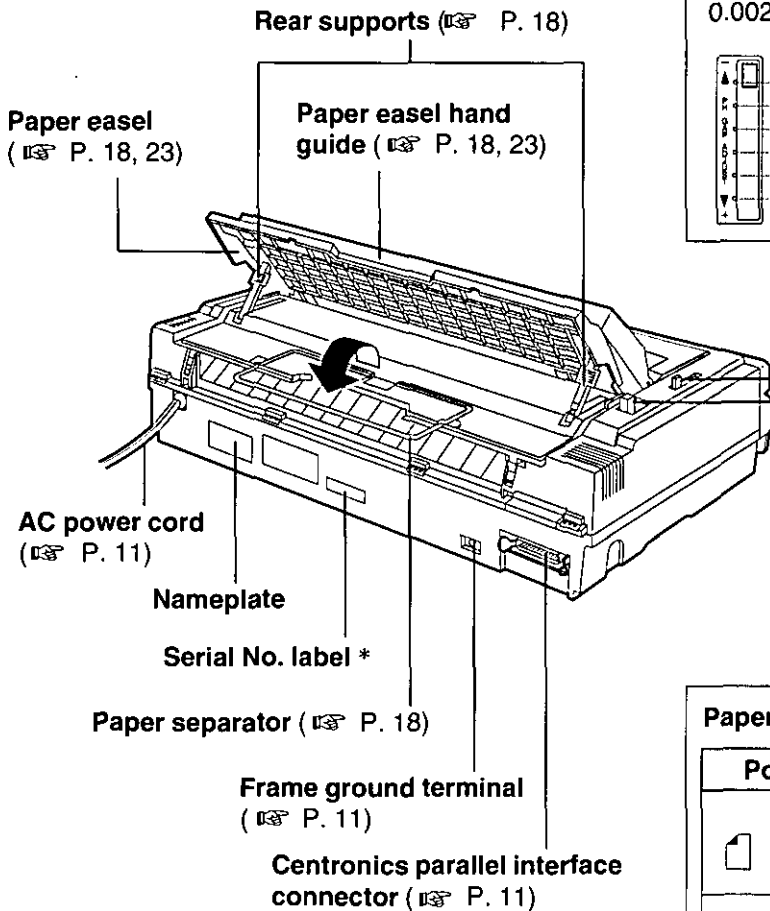
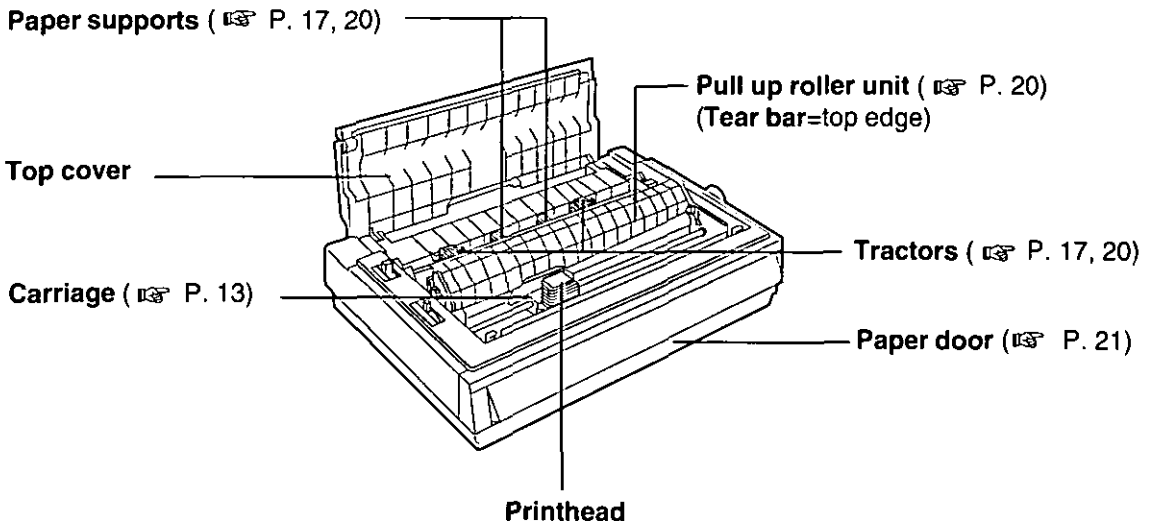

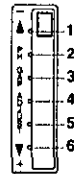

### Head gap lever

Adjusts the gap between the platen and the printhead. The lever moves in increments of 0.0028 inch (0.07 mm).



Position	Used for
1 or 2	Thinner sheets
3, 4, 5 or 6	Thick sheets, multi-part forms or envelopes

### Paper feed selector

Position	Used for
 (Friction)	Single sheets and envelopes
 (Tractor)	Fanfold paper (Front, bottom and rear feeding)

\* For units sold in Canada, Serial No. is located on the Nameplate.

# Connecting to a Computer

1

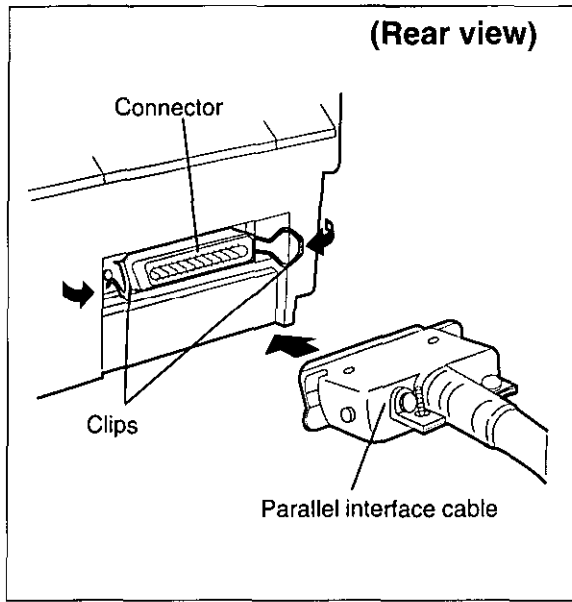

Attach the other end of the parallel interface cable from your computer to your printer and secure the printer clips.

**Note:**

- If you do not have a parallel interface cable, you will need to purchase one from your local computer store or dealer.

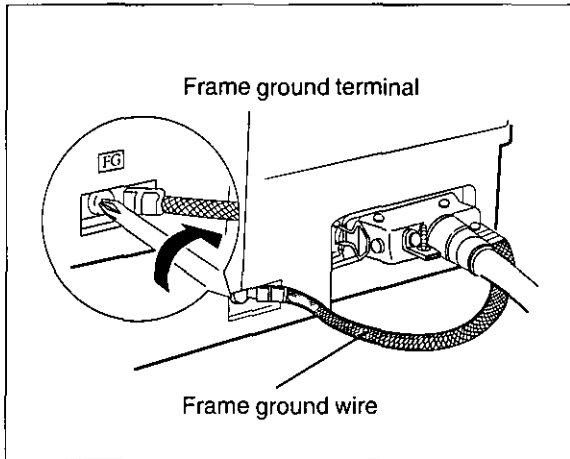

If the cable has a frame ground wire, connect it to the frame ground terminal.

2

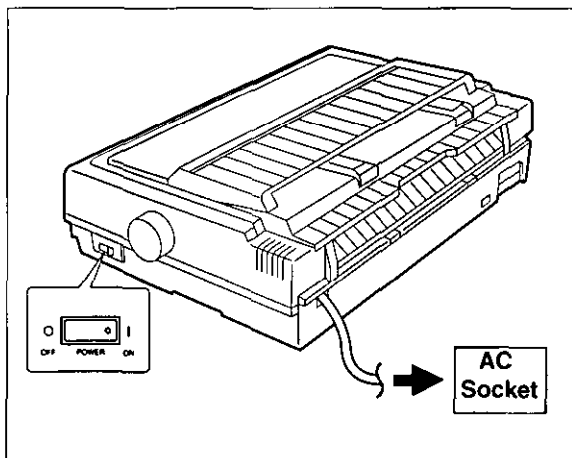

Plug printer into a grounded 3 prong AC socket.

When the power is supplied to the printer, the power indicator on the control panel will light.

# Ribbon Cassette

## Installing the Ribbon Cassette

1

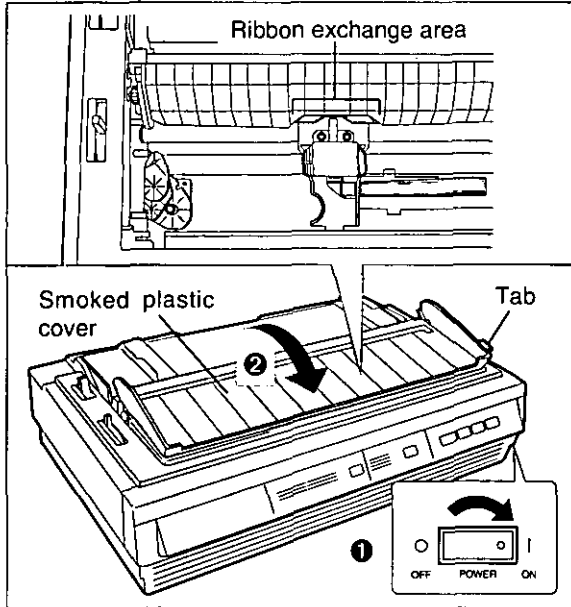

1 Turn the power on.

The carriage will automatically move to the ribbon exchange area.

Note:

- The ribbon cassette can only be installed in this area.

2 Fold forward the smoked plastic cover.

2

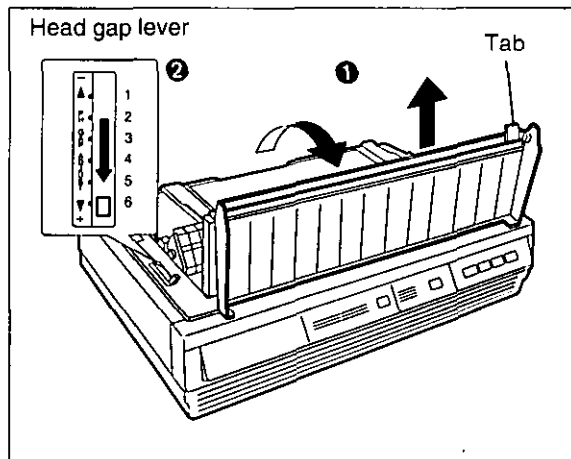

1 Raise the smoked plastic cover and remove it.

2 Move the head gap lever to the (+) position.

Note:

- Be careful not to drop the smoked plastic cover.
- The printhead may be hot, use caution when cover is open.

3

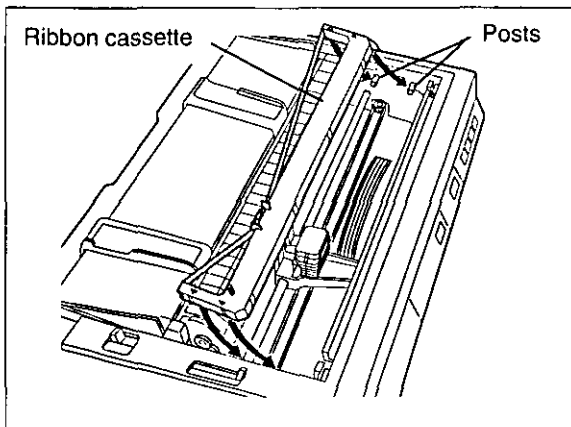

Lower the ribbon cassette onto the four ribbon posts (gold in color), insert the back portion of the ribbon into the printer first.

4

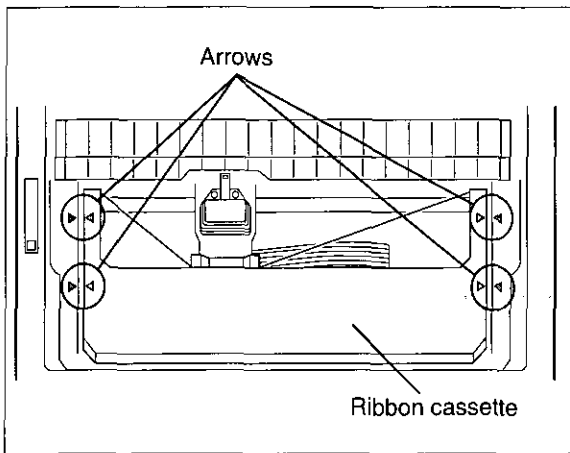

Line up the 4 arrows on the ribbon cassette with the arrows on the left and right sides of the frame. Push 4 arrows down until they click into place.

**Note:**

- Make sure that the ribbon cassette is perfectly placed in position.

5

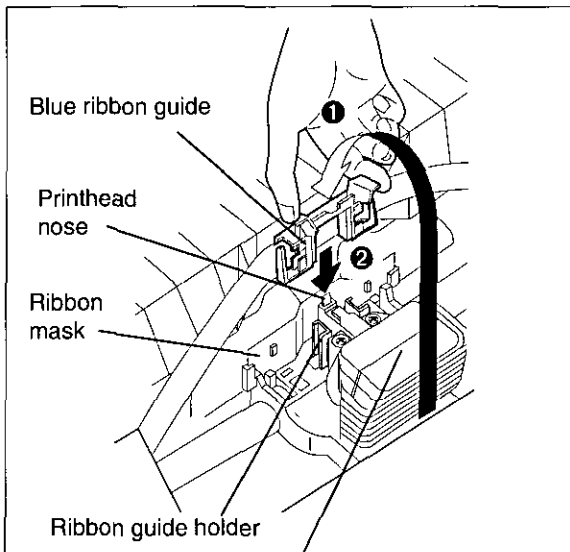

① Grasp the top of the blue ribbon guide with your thumb and forefinger, remove the blue ribbon guide by lifting from the ribbon cassette.

② Slide the blue ribbon guide onto the ribbon guide holder of the carriage and push the blue ribbon guide down.

**Note:**

- If the ribbon does not insert easily between the printhead nose and the ribbon mask rotate the knob to reduce slack.

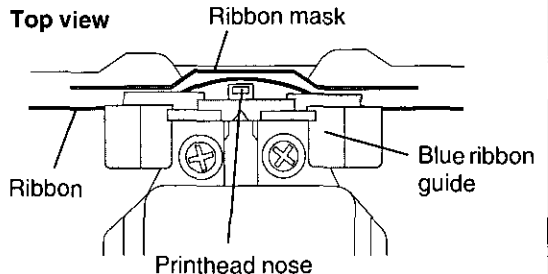

**CAUTION**  
HOT SURFACE  
DO NOT TOUCH !

6

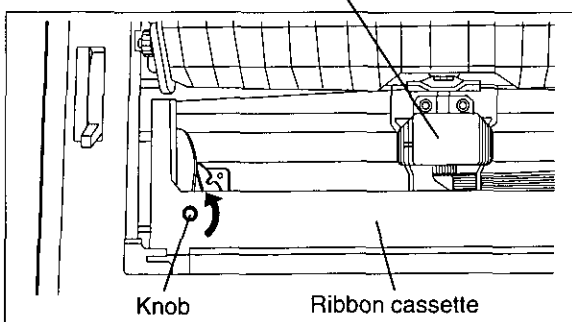

Rotate the knob on the ribbon cassette counterclockwise to remove any slack.

# Ribbon Cassette

7

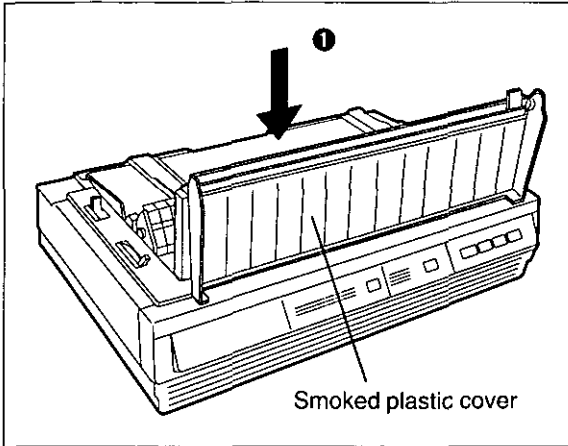

① Replace the smoked plastic cover

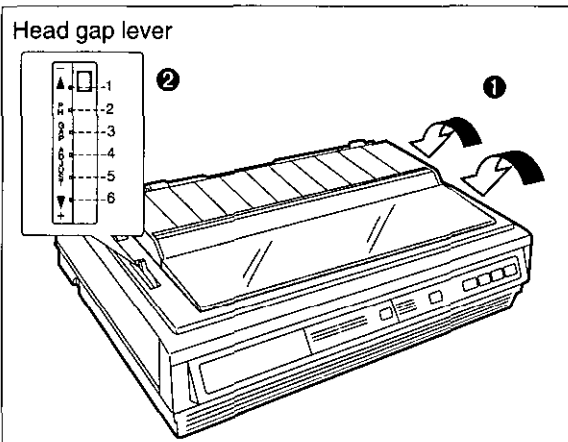

② Adjust the head gap lever for the thickness of paper you are using.

Position	Used for
1 or 2	Thinner sheets
3, 4, 5 or 6	Thick sheets, multi-part forms or envelopes

## Removing the Ribbon Cassette

1 To remove the ribbon cassette, perform step 1~2 of “Installing the Ribbon Cassette” at first. (☞ P. 12)

2 Then reverse the installation procedure. (step 5 → step 4 → step 3 of “Installing the Ribbon Cassette”. (☞ P. 12~13)

**Caution:**

- The printhead may be hot, use caution when cover is open.
- Do not lift up the flat cable located under the carriage when removing the ribbon cassette. It may break off.

# Paper Feed Selection

This printer supports 4 paper paths (rear, bottom, front and top feeding). Rear, bottom and front feedings are for continuously fed paper. Top feeding is for single sheets or envelopes.

The optional KX-P38 Cut Sheet Feeder will accommodate automatic feeding of up to 80 single sheets from the top paper path.

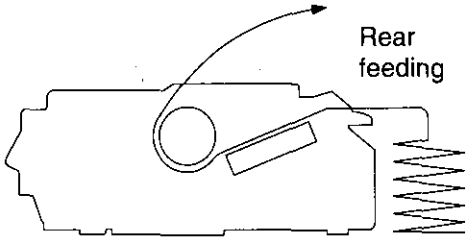
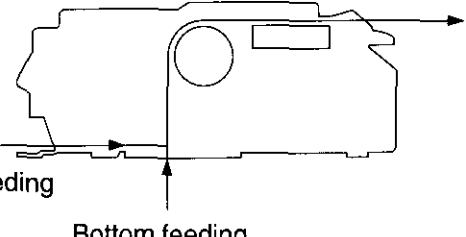
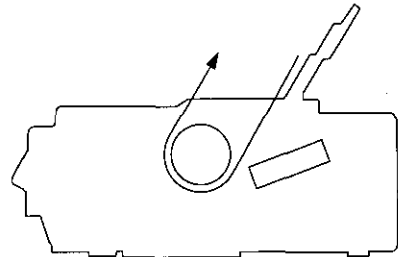
<p><b>Rear feed</b> ( P. 16)</p> <ul style="list-style-type: none"> <li>— fanfold paper (1 part)</li> <li>— multipart fanfold forms</li> </ul>	
<p><b>Bottom and Front feed</b> ( P. 19)</p> <ul style="list-style-type: none"> <li>— multipart fanfold forms</li> <li>— fanfold labels</li> <li>— fanfold paper (1 part)</li> </ul>	
<p><b>Top feed</b> ( P. 23)</p> <ul style="list-style-type: none"> <li>— single sheets (The optional KX-P38 Cut Sheet Feeder allows you to automatically feed up to 80 sheets of 20 lb paper.)</li> <li>— multipart single forms</li> <li>— envelopes</li> </ul>	

**Note:**

- For optimum print quality, do not use reverse line feeding in bottom and front feeding. If reverse feeding is necessary in bottom and front feeding, set **REVERSE LF/PULL** in the **INSTALL** menu to **ON** by using the Setup Disk.
- Paper Parking is not available in bottom and front feeding.
- When using multipart fanfold paper especially in environments that have very high or low temperature and/or humidity, we recommend the use of the bottom feed pull mode to optimize paper handling and print quality.

# Installing Paper

## Fanfold Paper: (Rear Feed/Push Tractor Mode)

1

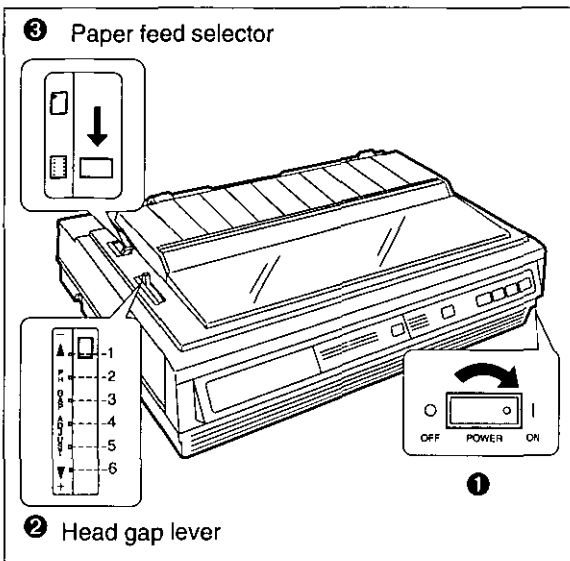

① Turn the power on.

The PAPER OUT indicator will flash indicating that paper is not installed in the printer.

② Adjust the head gap lever for the thickness of paper you are using.

Position	Used for
1 or 2	Thinner sheets
3, 4, 5 or 6	Thick sheets or multi-part forms sheets

③ Set the paper feed selector to “” (Tractor Mode).

2

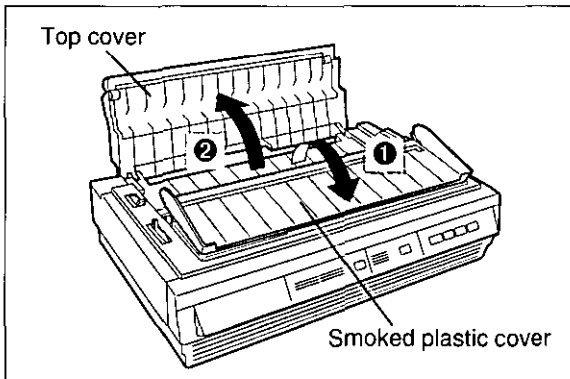

① Fold forward the smoked plastic cover.

② Open the top cover.

3

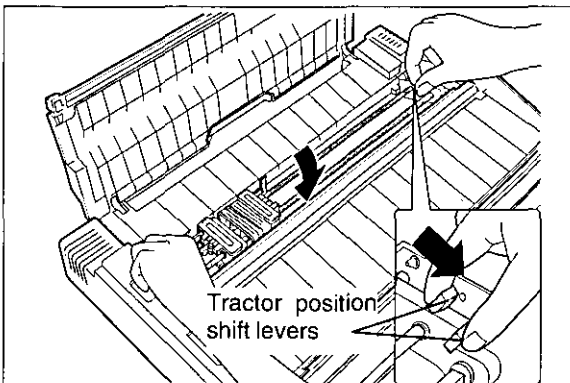

Pinch both left and right tractor position shift levers and lower the tractor mechanism downward until the tractors fall into place, then release.



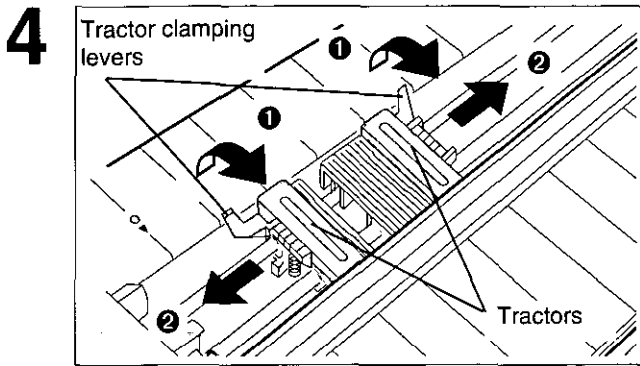

- ❶ Unlock the tractors by pulling the tractor clamping levers forward.
- ❷ Slide the tractors to accommodate the approximate width of the paper being used.

In most applications, you will find that the “0” indicator on the tear bar is a useful tool for predetermining your left most print position.

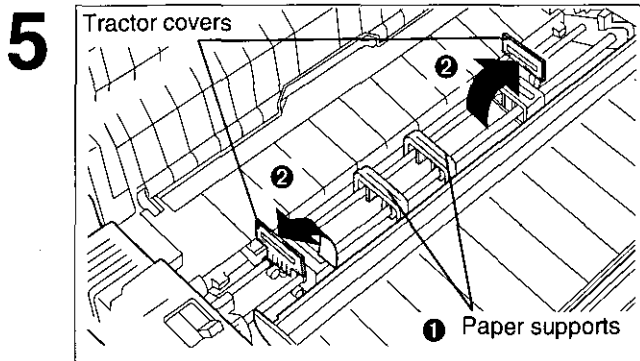

- ❶ Slide the two paper supports between the tractors at equal spaces.

- ❷ Open the tractor covers.

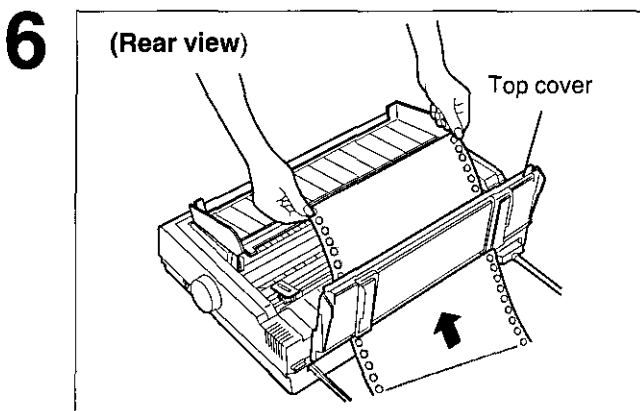

Feed paper through opening between printer and the top cover.

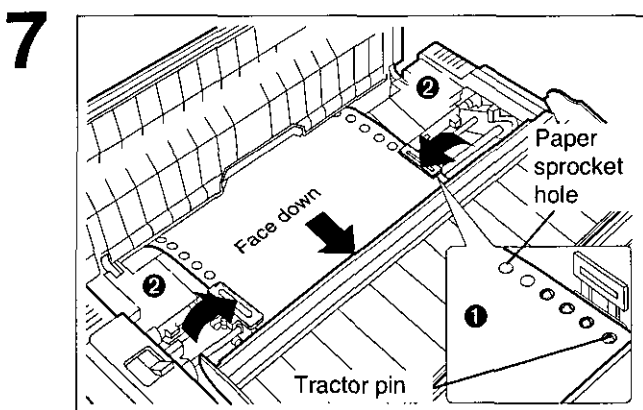

- ❶ Align the paper sprocket holes with the tractor pins, making sure the paper is straight.

- ❷ Close the tractor covers.

# Installing Paper

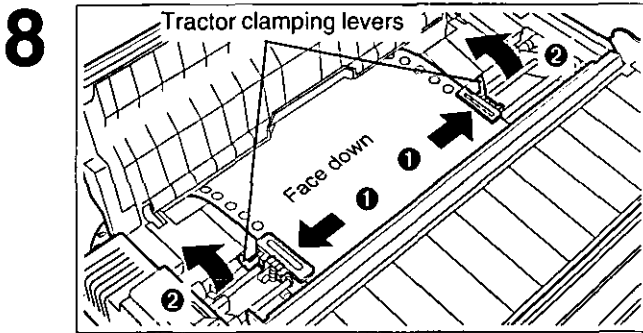

- ❶ Adjust the tractors to remove any slack in the paper.
- ❷ Lock the tractors by pushing the tractor clamping levers back.

**Note:**

- Put the tractor pins in the center of the paper sprocket holes when locking.

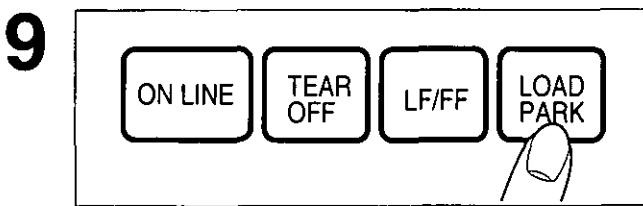

Press **LOAD/PARK**.

This will load the paper to the first print line.

**Note:**

- Do not use **LF/FF** to load paper.

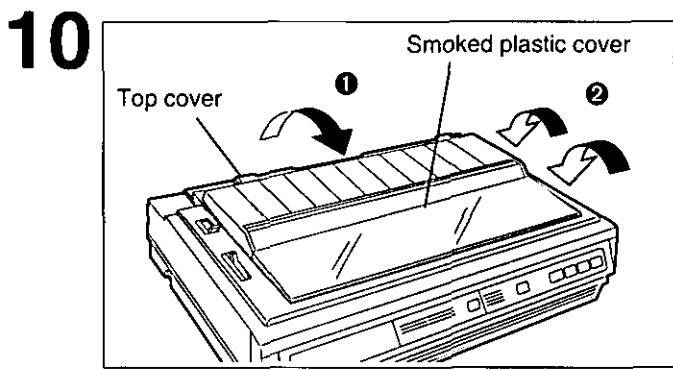

- ❶ Close the top cover.
- ❷ Fold back the smoked plastic cover.

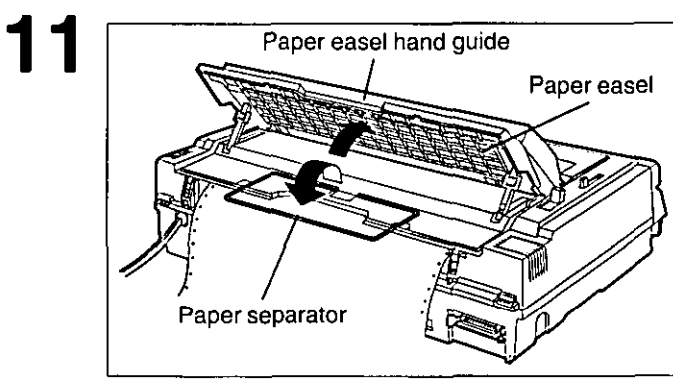

Extend the paper separator by first raising the paper easel by lifting the paper easel hand guide and then unfolding it.

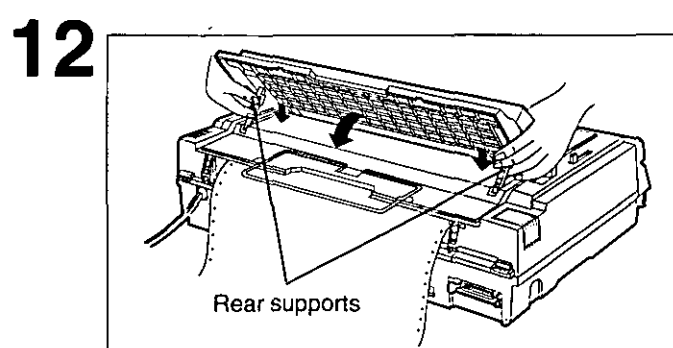

Lower the paper easel by simultaneously depressing the rear supports.

**Note:**

- Be careful not to pinch your fingers.
- When in tractor mode please do not use paper guides to guide the paper path. In tractor mode the paper is guided by the tractor units themselves.

# 13

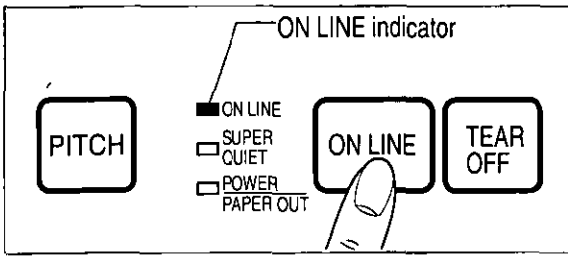

If **ON LINE** indicator is not lit, press **ON LINE** to get ready to print.

**Note:**

- If setting up the printer for the first time, proceed to Printer Driver Selection. (P. 26)

## Fanfold Paper: (Bottom, Front Feed/Pull Tractor Mode)

# 1

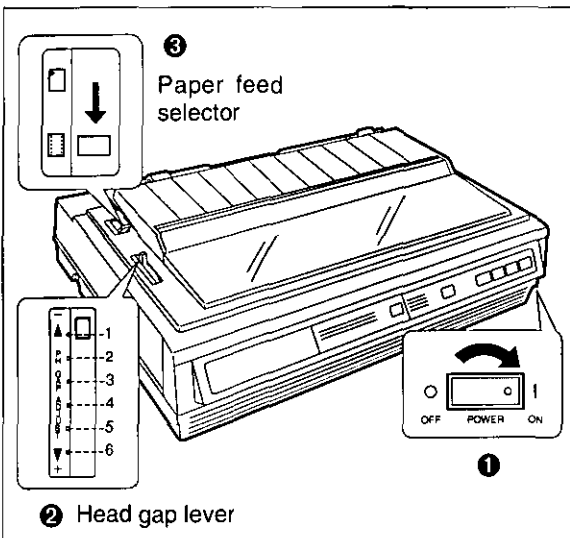

❶ Turn the power on.

The PAPER OUT indicator will flash indicating that paper is not installed in the printer.

❷ Adjust the head gap lever for the thickness of paper you are using.

Position	Used for
1 or 2	Thinner sheets
3, 4, 5 or 6	Thick sheets or multi-part forms sheets

❸ Set the paper feed selector to "6" (Tractor Mode).

# 2

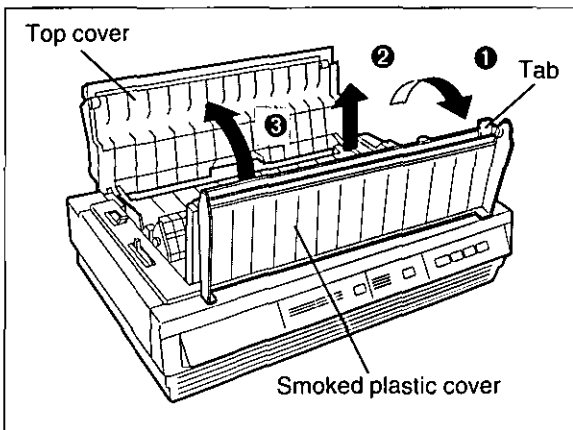

❶ Fold forward the smoked plastic cover and raise it.

❷ Remove the smoked plastic cover.

❸ Open the top cover.

# Installing Paper

3

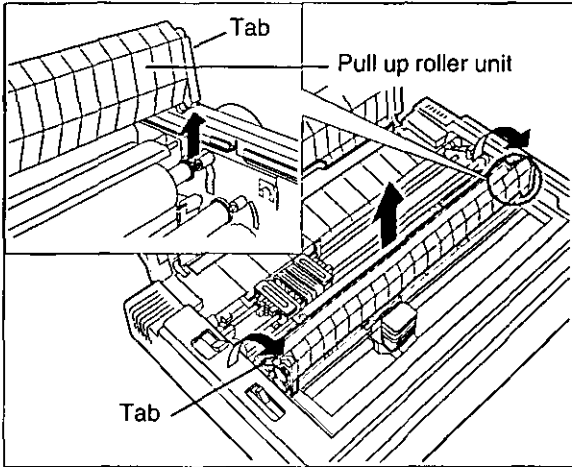

Remove the pull up roller unit by gently rotating forward using the tab until you feel it release, then lift up.

**Note:**

- Do not misplace the pull up roller unit.

4

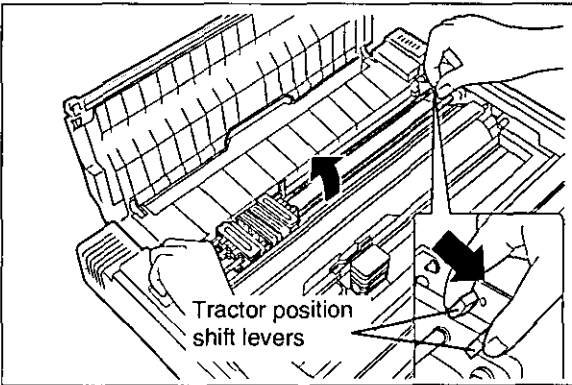

Pinch both left and right tractor position shift levers, and lift the tractor mechanism up then release the levers.

5

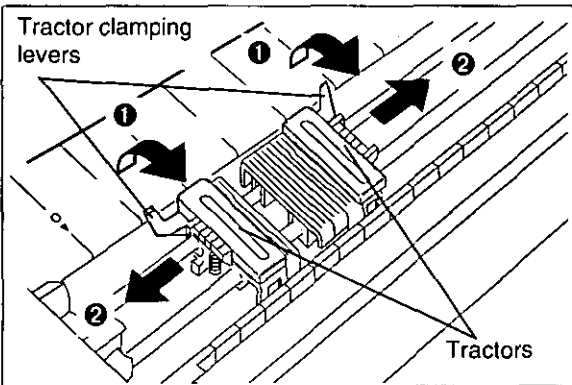

- 1 Unlock the tractors by pulling the tractor clamping levers forward.
- 2 Slide the tractors to accommodate the approximate width of the paper being used.

In most applications, you will find that the "0" indicator on the back of the cover is a useful tool for predetermining your left most print position.

6

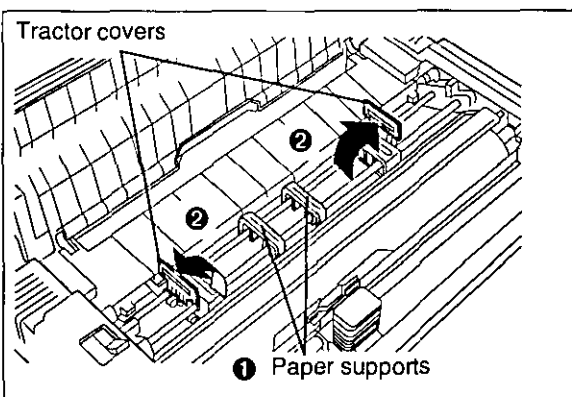

- 1 Slide the two paper supports between the tractors at equal spaces.
- 2 Open the tractor covers.

7

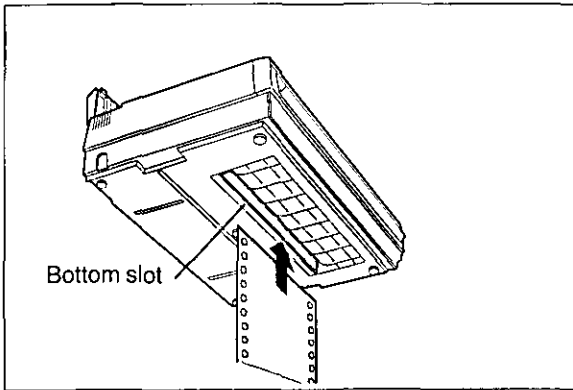

### When Bottom Feeding:

With the printer being supported by a printer stand, or on a table that allows for bottom feed, push the paper up through the bottom opening until it appears in front of the platen.

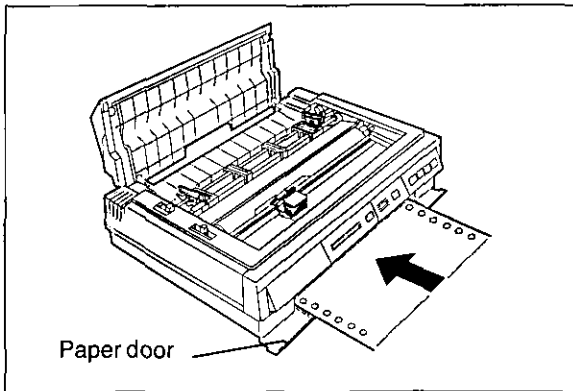

### When Front Feeding:

Open the paper door and insert the paper until it appears in front of the platen.

#### Note:

- When feeding fanfold paper or labels through the front paper door, paper types and condition, as well as temperature and humidity conditions may effect accurate line feeding and print quality may not be optimum. For optimum output bottom feed is recommended.

8

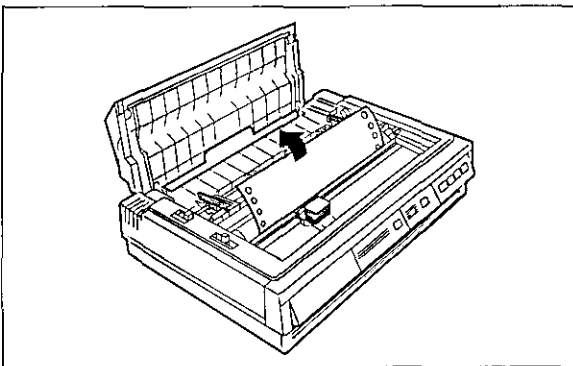

Adjust the paper position by pulling it up as shown.

9

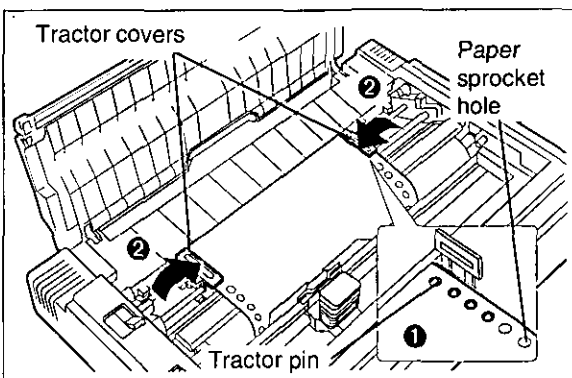

1 Align the paper sprocket holes with the tractor pins, making sure the paper is straight.

2 Close the tractor covers.

# Installing Paper

10

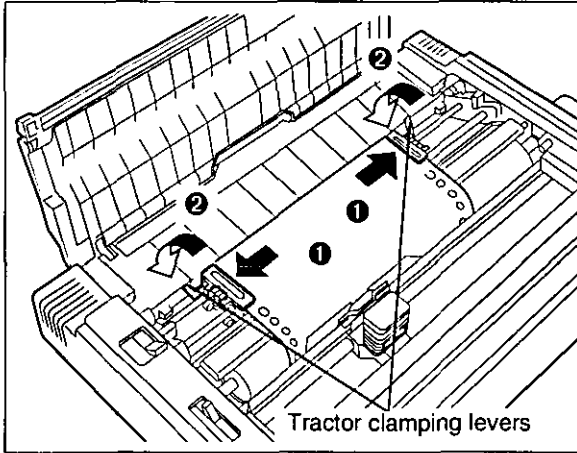

- ① Adjust the tractors to remove any slack in the paper.
- ② Lock the tractors by pushing the tractor clamping levers back.

**Note:**

- Put the tractor pins in the center of the paper sprocket holes when locking.

11

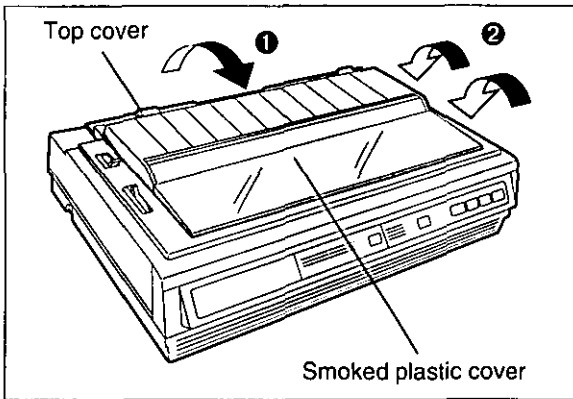

- ① Close the top cover.
- ② Replace the smoked plastic cover.

12

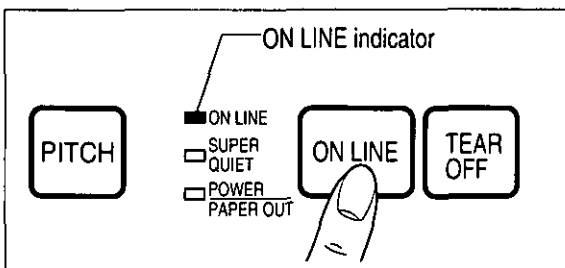

If **ON LINE** indicator is not lit, press **ON LINE** to get ready to print.

**Note:**

- If setting up the printer for the first time proceed to Printer Driver Selection. ( P. 26)

**Note:**

- In bottom and front feed, reverse feed functions will not feed paper correctly and the resulting printout may not be correct. If reverse feeding is necessary in bottom or front feed, set **REVERSE LF/PULL** in the **INSTALL** menu to **ON** by using the Setup Disk.
- When in tractor mode please do not use paper guides on the top cover to guide the paper . In tractor mode the paper is guided by the tractor units themselves.

## Single Sheets and Envelopes: (Top Feed/Friction Mode)

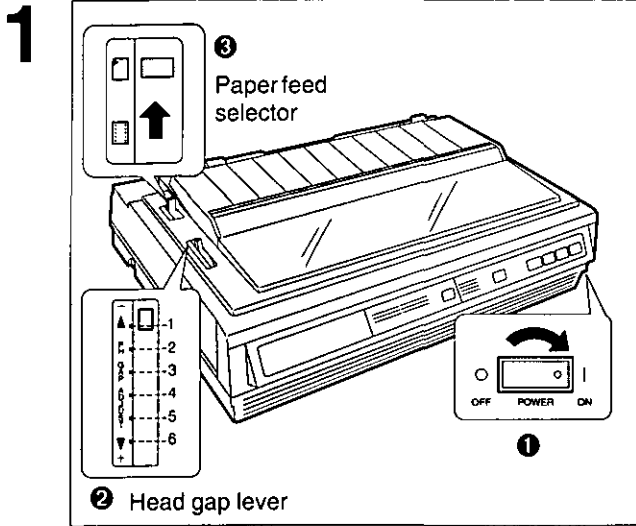

**1 Turn the power on.**

The PAPER OUT indicator will flash indicating that no paper is installed in the printer.

**2 Adjust the head gap lever for the thickness of paper you are using.**

Position	Used for
1 or 2	Thinner sheets
3, 4, 5 or 6	Thick sheets or envelopes

**3 Set the paper feed selector to “” (Friction Mode).**

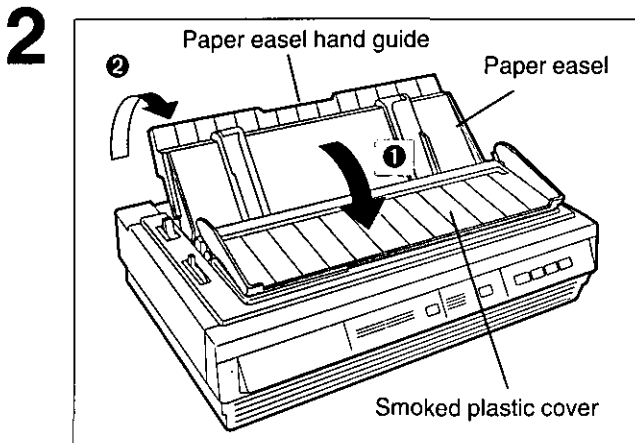

**1 Fold forward the smoked plastic cover.**

**2 Raise the paper easel by lifting the paper easel hand guide.**

# Installing Paper

3

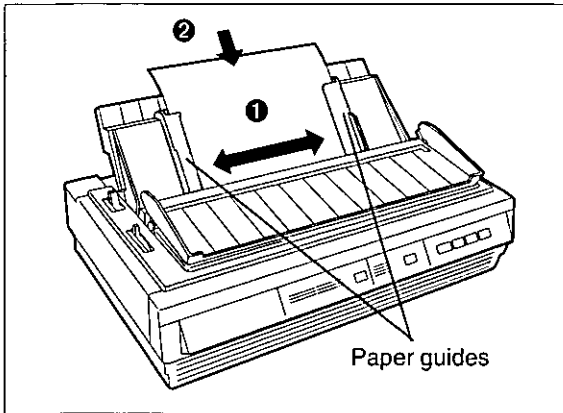

- 1 Separate the paper guides to the approximate width of your paper or envelope.

**Note:**

- To predetermine your left most print position, move the left paper guide until it clicks into place.

- 2 Insert a sheet of paper through the paper guides.

The paper will automatically be loaded to the first print position.

**Note:**

- To disable Auto Loading, turn it OFF in the Install Menu on your Setup Disk. ( P. 30)
- If Auto Loading is disabled, you must press **LOAD/PARK** to load paper.
- If you need to align the paper horizontally or vertically, set the paper feed selector to " " . This releases the paper and allows the paper to be positioned manually as required. Set the selector back to " " before printing.

- 4 Fold back the smoked plastic cover.

5

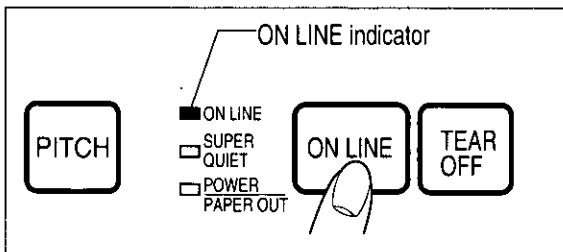

If **ON LINE** indicator is not lit, press **ON LINE** to get ready to print.

**Note:**

- If setting up the printer for the first time, proceed to Printer Driver Selection. ( P. 26)

**Note:**

- When the paper feed selector is in " " , the buzzer will sound to inform you that the selector is in the wrong position.
- When loading an envelope, if the envelope will not load smoothly, move the paper feed selector to " " and insert the envelope manually, then move the selector back to " " .





# Printer Driver Selection

The printer driver allows your application software to properly control your printer's features. The printer driver is contained in your application software.

Selecting a printer driver is the final step before printing and is performed in your application software program. The steps will vary, depending on the software program. Consult your software package for proper procedures. The Panasonic KX-P3626 will be your first choice. However, if the Panasonic KX-P3626 printer is not listed in your software, you must select an alternative from the following table.

**Note:** If using Microsoft Windows Version 3.1, you will need to install a Windows printer driver. This driver is located on the Setup Disk supplied with your printer. Proceed to Installing a Printer Driver section on page 27 for the installation procedure.

## Printer Driver Selections (in order of priority)

Printer Selections
Panasonic KX-P3626
Panasonic KX-P3624
Epson LQ-1170 (ESC/P2™)
Panasonic KX-P3123/3124
Panasonic KX-P2624
Epson LQ series
IBM Proprinter XL24E*

\* If selecting the IBM Proprinter XL24E in your software, printer emulation must also be changed in the Initial Setup items. ( P. 28~39, 47~49)

# Installing a Printer Driver (Windows Ver. 3.1)

The following steps are only necessary if using Microsoft Windows Version 3.1. The Setup Disk packaged with your printer contains a Panasonic KX-P3626 Printer Driver for Windows Version 3.1. To install this printer driver, you must begin at the Program Manager screen in your Windows program. Follow the steps below for the proper installation procedure.

**Note:**

- Use the DISKCOPY command of the operating system to make a back-up copy. Refer to your DOS manual for further information.

**1** In "Main Group", select "Control Panel".

**2** In "Control Panel", select "Printers".

If you have installed a printer driver, the dialog box expands to display a list of printers available in the Windows Ver. 3.1 package, and **Add>>** is unavailable. In "Installed Printers", select the printer you want. Go to step 9.

**3** Click **Add>>**.

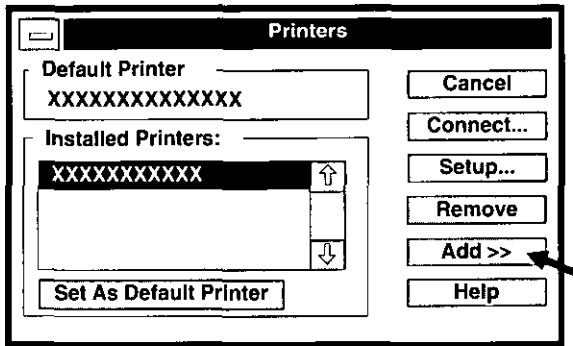

**4** In "List of Printers", select "Install Unlisted or Updated Printer".

**5** Click **Install...**.

**6** Insert the Setup Disk into drive A.

If reading the printer driver disk from drive B, type B:\

**7** Click **OK**.

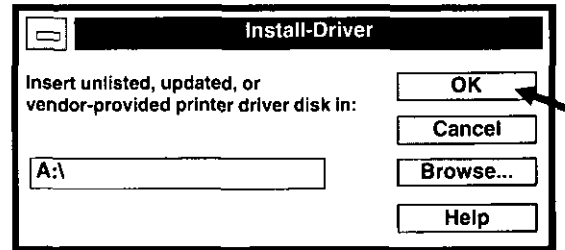

The printer driver KX-P3626 is shown in the dialog box.

**8** Click **OK**.

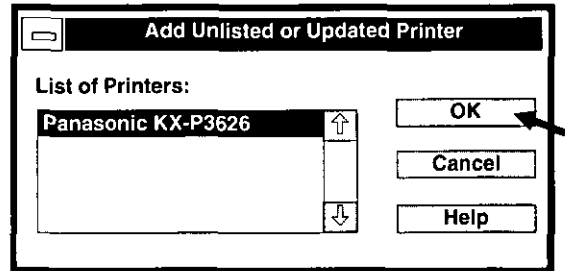

**9** Click **Set As Default Printer**.

**10** Click **Close**.

**11** Exit the "Control Panel".

# Initial Setup Mode

This printer allows you to select 48 initial setup items shown in the table below. You can select all these items by using the Setup Disk.

Menu	Item	Setting			Description
PRINT STYLE	FONT	Draft*	Super LQ		Selects Draft, LQ (Letter Quality), SLQ (Super Letter Quality) or SC (Scalable).
		Bold PS	Bold PS-SC		
		Courier	Courier-SC		
		OCR-B	Prestige-SC		
		Prestige	Roman-SC		
		Roman	Sans Serif-SC		
		Sans Serif	Script-SC		
		Script			
	PITCH	10 CPI*	PROPORTIONAL		Selects the desired characters per inch (cpi) or Proportional Spacing.
		12 CPI	5 CPI		
		15 CPI	6 CPI		
		17 CPI	7.5 CPI		
		20 CPI	8.5 CPI		
	POINT SIZE [displayed only when -SC sequences are selected in Font.]	10.5* (8 to 96) Point			The number increases or decreases by 2 (plus 10.5 and 21).
EMULATION	EMULATION	EPSON*			Sets the emulation mode to Epson LQ-1170 or IBM Proprinter XL24E.
		IBM			
PAGE FORMAT	LINE/INCH	1 LPI	4 LPI	8 LPI	Selects the desired lines per inch (cpi). "Scalable" can be set only when a SC FONT is selected in the FONT Setting.
		1.5 LPI	4.5 LPI	9 LPI	
		2 LPI	5 LPI	10 LPI	
		2.5 LPI	6 LPI*	12 LPI	
		3 LPI	7.5 LPI	Scalable	
	PAGE LENGTH	14 inch	8.5 inch		When you select "FREE", the number increases or decreases by 1/72" from 0.5" to 15.0".
		12 inch	8 inch		
		11 2/3 inch	5.5 inch		
		11 inch*	FREE		
	TOP MARGIN	0.00"* to 2.50" (0.00 cm to 6.35 cm)			The number increases or decreases by 1/72" (about 0.35 mm).
	BOTTOM MARGIN	0.00"* to 5.00" (0.00 cm to 12.70 cm)			The number increases or decreases by 1/72" (about 0.35 mm).
	LEFT MARGIN	0* to 134 column (10 CPI)			The value number depends on the PITCH and PRINT WIDTH selected.
	RIGHT MARGIN	2 to 136* column (10 CPI)			The value number depends on the PITCH and PRINT WIDTH selected.
	CTR PRINTHEAD (Centering printhead)	42* (10 to 80) column (10 CPI)			The number increases or decreases by 1.

\* denotes setting when shipped from factory.

Menu	Item	Setting	Description
PRINT MODE	GRAPHIC DIRECTION	BI DIRECTION UNI DIRECTION*	Graphics are printed left-to-right only (UNI DIRECTION) or in both directions (BI DIRECTION).
	TEXT DIRECTION	BI DIRECTION* UNI DIRECTION	Text is printed left-to-right only (UNI DIRECTION) or in both directions (BI DIRECTION).
	PRINT WIDTH	13.6 inch* 8.0 inch	Selects the desired print width.
TEXT ENHANCEMENT	BOLD (determines weight or thickness of a character)	OFF* ON	Activates bold printing (ON), deactivates bold printing (OFF).
	DOUBLE HIGH (height of a character is twice that of a normal one)	OFF* ON	Activates double high printing (ON), deactivates double high printing (OFF).
	DOUBLE STRIKE (two passes of the printhead)	OFF* ON	Activates double strike printing (ON), deactivates double strike printing (OFF).
	DOUBLE WIDE (width of a character is twice that of a normal one)	OFF* ON	Activates double wide printing (ON), deactivates double wide printing (OFF).
	ITALICS	OFF* ON	Activates italic printing (ON), deactivates italic printing (OFF).
	OUTLINE	OFF* ON	Activates outline printing (ON), deactivates outline printing (OFF).
	SHADOW	OFF* ON	Activates shadow printing (ON), deactivates shadow printing (OFF).
CHARACTER SET	COUNTRY	U.S.A.*      JAPAN FRANCE      NORWAY GERMANY     DENMARK 2 U.K. (England) SPAIN 2 DENMARK 1   L.AMERICA SWEDEN      (Latin America) ITALY        KOREA SPAIN 1      LEGAL	Selects one of 14 language or legal character sets.
	CHARACTER SET	ITALIC* GRAPHIC 1 GRAPHIC 2	Selects the italics or graphics/character sets 1 or 2. ("ITALIC" is available only in the Epson mode.)
	CODE PAGE	U.S.A.*      NORWAY MULTILINGUAL    TURKEY PORTUGAL CANADA FRENCH	Selects one of 6 code pages.

\* denotes setting when shipped from factory.

# Initial Setup Mode

Menu	Item	Setting	Description
INSTALL	AGM/IBM (Alternate Graphics Mode)	OFF* ON	Sets Alternate Graphics mode (selects Epson graphics) to on or off in the IBM mode. (This setting is effective only in the IBM mode.)
	AUTO CR/IBM	OFF* ON	Activates (ON) or deactivates (OFF) Automatic CR on LF, VT, ESC+"J". (This setting is effective only in the IBM mode.)
	AUTO LF	OFF* ON	Activates (ON) or deactivates (OFF) Automatic LF after CR.
	BUZZER	OFF ON*	Buzzer sounds (ON) or doesn't sound (OFF).
	AUTO LOADING	OFF ON*	Setting to ON automatically loads a single sheet or envelope to the first print line. [This setting is inoperative when using the optional Cut Sheet Feeder (KX-P38)].
	PAPER OUT DETECT	OFF ON*	Paper Out Detector is active (ON) or ignored (OFF).
	SUPER QUIET MODE	OFF* ON	Reduces (ON) or doesn't reduce (OFF) the printing noise.
	REVERSE LF/PULL	OFF* ON	Setting to ON enables the reverse feeding in bottom and front feed.
	TEAR OFF	MANUAL* AUTO	When set to MANUAL, the paper's perforation doesn't advance to the tear off position unless you press the <b>TEAR OFF</b> . Setting to AUTO advances the paper's perforation to the tear off position automatically.
	CSF MODE	OFF* ON	[This setting is operational when using the optional Cut Sheet Feeder (KX-P38)].
	DOWNLOAD	OFF* ON	Setting to ON allows you to download (user-defined) special characters and setting to OFF allows you to send more data to your printer's buffer, thereby freeing up your computer.
	AUTO ON LINE	OFF ON*	Setting to ON enables the printer to automatically enter ON LINE mode after installing paper.

\* denotes setting when shipped from factory.

Menu	Item	Setting	Description
INTERFACE [The setting is effective only when the optional KX-PS14, RS-232C serial interface board is installed.]	INTERFACE	PARALLEL* SERIAL	Selects parallel interface or serial interface.
	DATA LENGTH	8 BITS* 7 BITS	Selects data length 8 bits or 7 bits.
	BAUD RATE *1	150 BPS      2400 BPS 300 BPS      4800 BPS 600 BPS      9600 BPS* 1200 BPS	Selects the desired baud rate.
	PARITY *1	NONE*      ODD IGNORE      EVEN	Selects the desired parity.
	PROTOCOL *1	DTR* XON/OFF	Selects the desired protocol DTR or XON/OFF.
	SDT *1	RBC 128* RBC 512	Selects the remaining buffer capacity (R.B.C.) 128 byte or 512 byte to suspend data transfer (S.D.T.) (X/OFF).
	RDT *1	SDT+128* SDT+256	Selects the remaining buffer capacity (R.B.C.) 128 byte or 256 byte to resume data transfer (R.D.T.) (X/ON).
	SIGNAL POLARITY *1	MARK* SPACE	Selects the signal polarity mark or space.
T.O.F. SETTING (Top of Form Setting)	TRACTOR	0.00" to 5.00" (60/180)** (0.00 cm to 12.70 cm)	The number increases or decreases by 1/180" (about 0.14 mm).
	FRICTION	0.00" to 5.00" (60/180)** (0.00 cm to 12.70 cm)	The number increases or decreases by 1/180" (about 0.14 mm).
	CUT SHEET FEEDER	0.00" to 5.00" (60/180)** (0.00 cm to 12.70 cm)	The number increases or decreases by 1/180" (about 0.14 mm). [This setting is operational when using the optional Cut Sheet Feeder (KX-P38)].

\* denotes setting when shipped from factory.

\*1 displayed only when SERIAL is selected in INTERFACE.

This Setup Disk can only be used in an IBM-PC or a compatible computer with a 3.5" floppy disk drive.

Before using the Setup Disk, it is recommended that you make a back-up copy and store the original in a safe place.

This printer has been factory set to operate with most of the popular software packages. In most cases there will be no need to change the initial setup items. Refer to pages 28-31 to verify that the factory settings meet your requirements. If no changes are required, you should be ready to print.

**Note:**

- Use the DISKCOPY command of the operating system to make a back-up copy. Refer to your DOS manual for further information.
- You may find it convenient to install the Setup Disk programs directly onto your C Drive, rather than reading them from the Setup Disk each time a change is necessary. Either method is acceptable.

To perform an automatic installation of the Setup Disk files onto your C Drive, follow the steps below:

1. Insert the Setup Disk into drive A or B.
2. Type **A:** (or **B:**) and press **Enter**.
3. Type **INSTALL** and press **Enter**.

This procedure automatically creates a directory called 3626 and copies all of the programs from your Setup Disk onto your C Drive. If you want to run the Initial Setup Program, press **Y**. If you want to exit, press **N**.

To recall the programs from your C Drive.

<For DOS>

At your C: \ > prompt, type **CD 3626** and press **Enter**.

Type **SETUP** and press **Enter**.

<For WINDOWS>

Select **Run** from the File menu.

Type **C:\3626\SETUP** and click **OK** (or press **Enter**).

Be sure to type **SETUP** as one word. If not, you will receive a Syntax error message.

## Running the Initial Setup Program

- 1 Insert your Setup Disk into either drive A or B.

<For DOS>

- 2 Type **A:** (or **B:**) and press **Enter**.

- 3 Type **SETUP**

- 4 Press **Enter**.

<For WINDOWS>

- 2 Select **Run** from the File menu.

- 3 Type **A:\SETUP** (or **B:\SETUP**)

- 4 Click **OK** (or Press **Enter**).



- 5 The first screen is an introduction to the operation of the Setup Disk. Please read it through and press any key to continue. (If your display is monochrome, press "M" key.)
- 6 The <Menu> window will be highlighted.

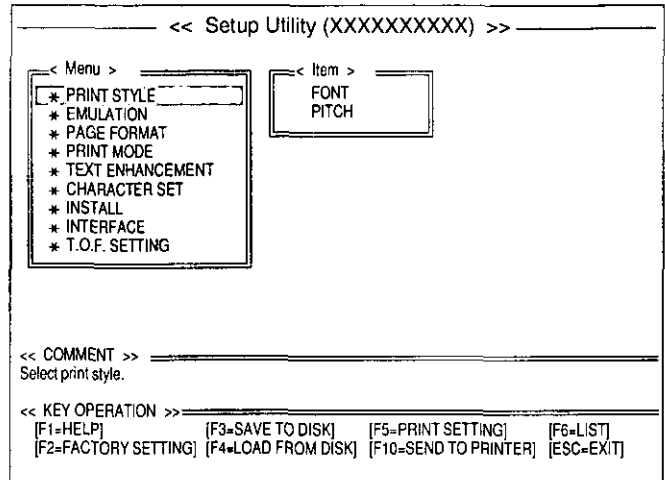

**Note:**

- You can proceed through the Setup Disk using a computer mouse or your arrow keys.

Using the keyboard:

- **↓** / **↑** to move within the current window.
- **→** to advance to <Item> and <Setting> windows.
- **Enter** to make selection in <Setting> window.
- **←** to return to the previous window.

Using the mouse:

- Highlight the selection and click the left mouse button.

## Exiting the Initial Setup Program

- 1 Press **ESC** until the "Exit" screen appears.

- "E": Exit to DOS.
- "C": Return to <MENU> window.

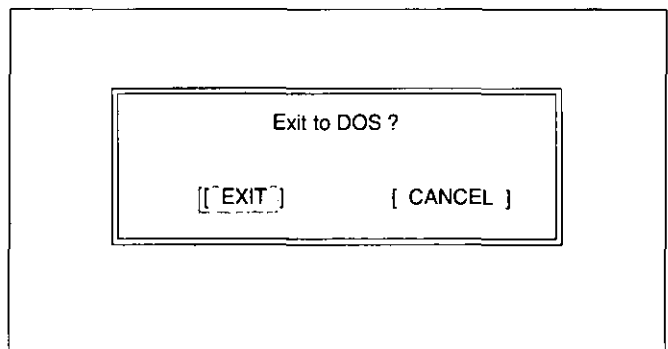





# Initial Setup Mode

**8** Press **←**.

<Menu> window will be highlighted.

To make additional changes in the <Menu> window, repeat steps 1 to 6.

**9** When all changes have been made, you may perform any one of the following operations:

- Save to Disk — **F3** (P. 36)
- Print Settings — **F5** (P. 34)
- Display Settings — **F6** (P. 34)
- Send to Printer — **F10** (P. 38)

**10** After performing one of the previous operations, and with the <Menu> window highlighted, press **ESC**.

**11** Press **E** or **C**.

"E": You have exited the Setup program.

"C": The display will return to the <Menu> window.

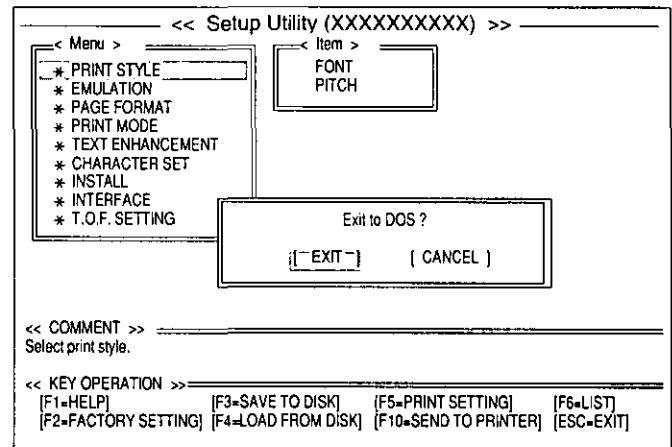
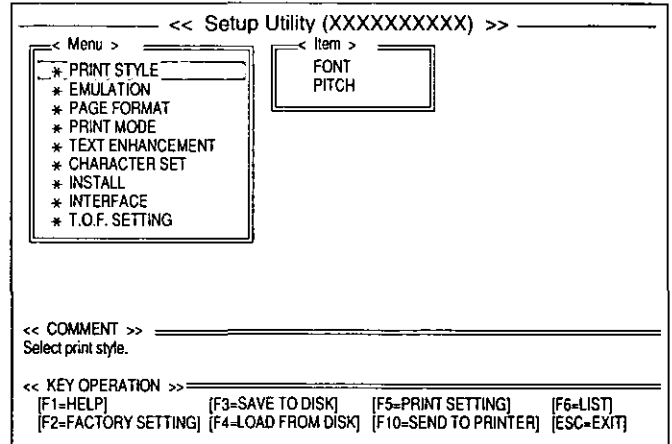

## Save to Disk

**1** Press **F3**.

A Save to Disk window will be displayed.

**2** To change Drive, press **TAB** four times and type the letter for the drive you want to use. To change Directory, press **TAB** a fifth time and select the new directory by using **↑** or **↓**, then press **Enter**.

If you do not change the Drive or Directory, proceed to Step 3.

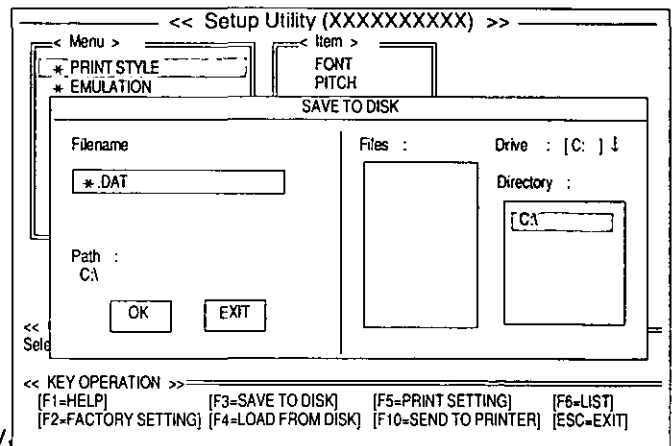

- 3** Press **TAB** repeatedly to move the cursor to the **Filename position. (\*.DAT)** Delete \* and enter a file name (up to 8 characters) and press **Enter**.

All the settings will be saved on the disk and the display will return to the Main screen.

**Note:**

- **SHIFT** + **TAB** performs a reverse tab function and moves the cursor to the previous selection.

If you want to save the setting(s) as a file name previously saved, after entering the same file name, press **Enter** then press **Y**.

“Y”: The current settings will be written over the old settings.

“N”: The display will return to a <Save to Disk> window.

## Load from Disk (Recall Settings)

- 1** Press **F4**.

A Load from Disk window will be displayed.

- 2** To change Drive, press **TAB** four times and type the letter for the driver you want to use. To change Directory, press **TAB** a fifth time and select the new directory by using **↑** or **↓**, then press **Enter**.

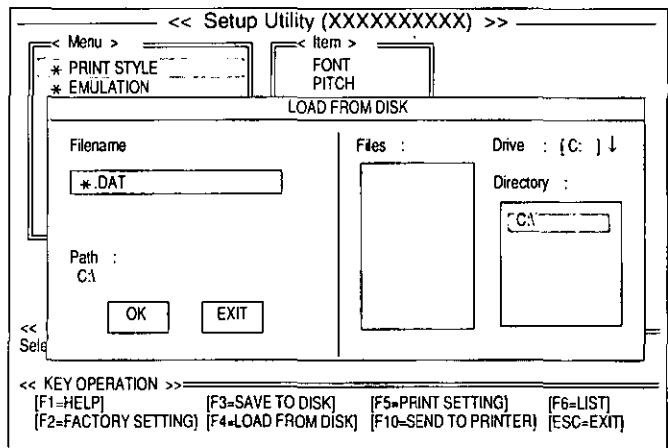

If you do not change the Drive or Directory, proceed to Step 3.

- 3** Press **TAB** repeatedly to move the cursor to the **Files position.**

# Initial Setup Mode

4 Use **↑** or **↓** to highlight your desired file name.

5 Press **Enter** .

All the settings in the file will be recalled. To view them on your screen, press **F6** .

To transfer these settings to your printer, you must perform the Send to Printer operation below.

## Send to Printer

1 Press **F10** .

A Send to Printer window will be displayed.

2 Press **Y** or **N** .

"Y": All the settings will be sent to the printer.

"N": The display will return to the Main screen.

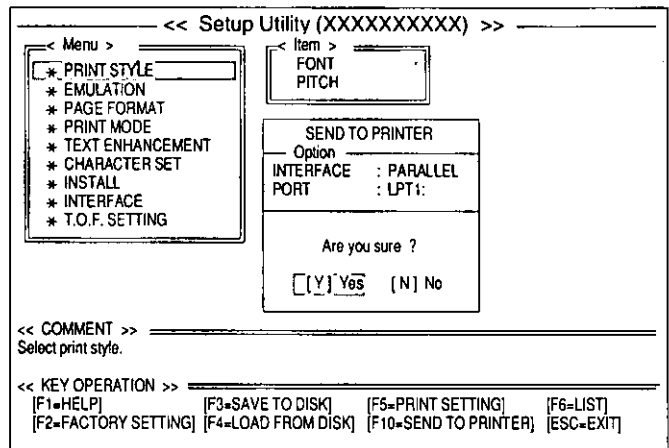

### Note:

- When sending the data by serial interface, change the option items on the display to the settings you desire. ( P. 34 "Print Settings")

## Resetting to Factory Setting

1 Press **F2** .

2 Press **Y** or **N** .

"Y": All the screen settings will be reset to the FACTORY settings.

"N": The display will return to the Main screen.

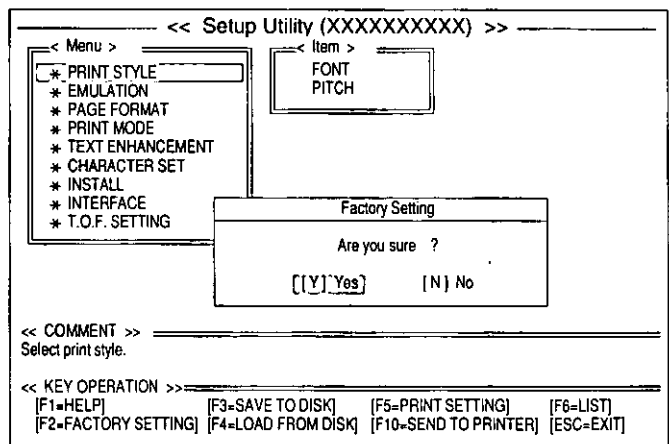

## 3 If **Y** was selected, you may then perform one of the following operations:

- Save to Disk — **F3** ( P. 36)
- Print Settings — **F5** ( P. 34)
- Display Settings — **F6** ( P. 34)
- Send to Printer — **F10** ( P. 38)

## Help

If you cannot remember what a particular function does, a HELP program will display to you the explanations of the functions.

### 1 Press **F1** .

A Help Item screen will be displayed.

### 2 Press **↑ / ↓ / → / ←** .

Highlight your desired item.  
(ex; AGM/IBM)

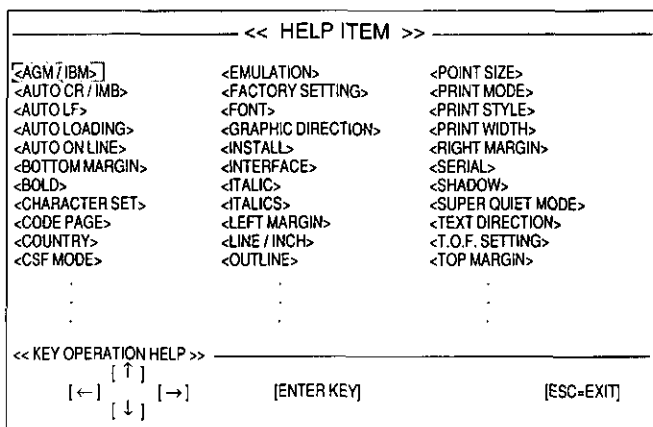

### 3 Press **Enter** .

A definition will be displayed.

### 4 Press **↑ / ↓** .

To move to the previous or next Help item without leaving the display.

### 5 Press **ESC** .

The Help Item screen will be displayed.

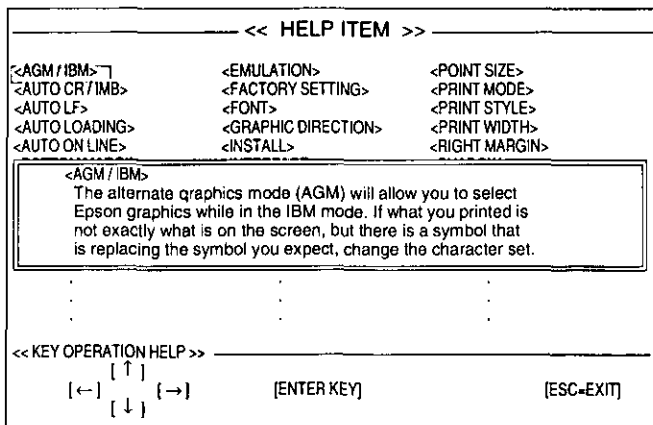

### 6 Press **ESC** .

The display will return to the Main screen.

# Using the Control Panel

## Selecting a Character Font

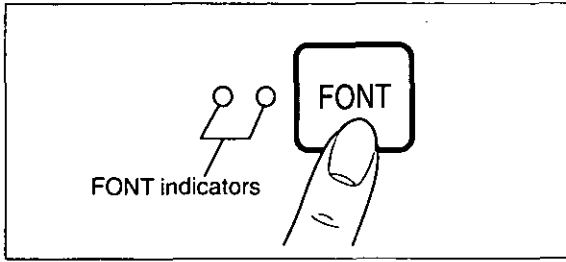

- Press and release **FONT**.

This printer contains resident fonts which are accessible through the Control Panel. You can select any one of the character fonts by pressing the FONT switch on the Control Panel. The combination of FONT indicators indicates the current character font selected, as shown below.

### EXAMPLES

○ ○ <b>FONT</b>	=PROGRAM	● ● <b>FONT</b>	=Bold PS	● ● <b>FONT</b>	=Sans Serif
● ○ <b>FONT</b>	=Courier	● ○ <b>FONT</b>	=Script	● ● <b>FONT</b>	=OCR-B
○ ● <b>FONT</b>	=Prestige	○ ● <b>FONT</b>	=Roman		

●=light is lit

○=light is out

●○=light is blinking

### Note:

- When the power is turned off, font will reset to default setting. If you want to save a font selection as your default, you may do so by using the Setup Disk. (P. 28)
- You must be in PROGRAM (both FONT indicators are off) to allow your software to control your font selection.

## Selecting a Character Pitch

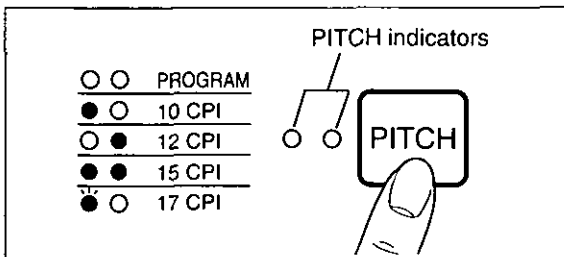

- Press and release **PITCH**.

This printer contains resident pitches which are accessible through the Control Panel. You can select any one of the character pitches by pressing the PITCH switch on the Control Panel. The combination of PITCH indicators indicates the current character pitch selected, as shown on the next page.



## EXAMPLES

- |     |              |          |     |              |         |
|-----|--------------|----------|-----|--------------|---------|
| ○ ○ | <b>PITCH</b> | =PROGRAM | ● ● | <b>PITCH</b> | =15 CPI |
| ● ○ | <b>PITCH</b> | =10 CPI  | ● ○ | <b>PITCH</b> | =17 CPI |
| ○ ● | <b>PITCH</b> | =12 CPI  |     |              |         |
- =light is lit      ○=light is out      ●=light is blinking

### Note:

- When the power is turned off, pitch will reset to default setting. If you want to save a pitch selection as your default, you may do so by using the Setup Disk. ( P. 28)
- You must be in PROGRAM (both PITCH indicators are off) to allow your software to control your pitch selection.

## Super Quiet Mode

The Super Quiet mode is a useful feature for further reducing print noise. Your printer has the capability of saving this feature by using the Setup Disk. ( P. 28~39)

### Note:

- When enabled, this feature will decrease your print speed.

### Turning on the Super Quiet mode:

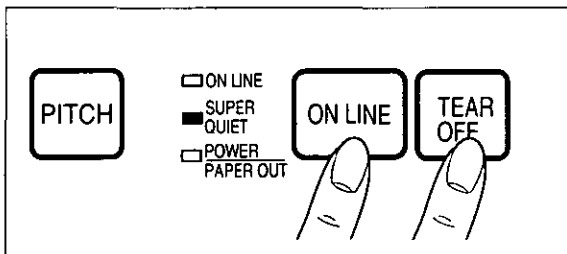

While pressing **ON LINE** ,  
press **TEAR OFF** .

The SUPER QUIET indicator is on.

### Turning off the Super Quiet mode:

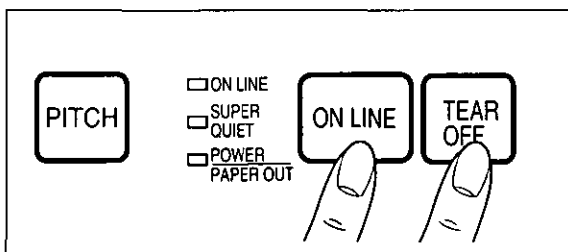

While pressing **ON LINE** ,  
press **TEAR OFF** .

The SUPER QUIET indicator is off.

## Line Feed/Form Feed **LF/FF**

You can adjust the paper position by using the front panel switches when the printer is in the OFF LINE mode or when the printer is not printing in the ON LINE mode.

### Line Feed

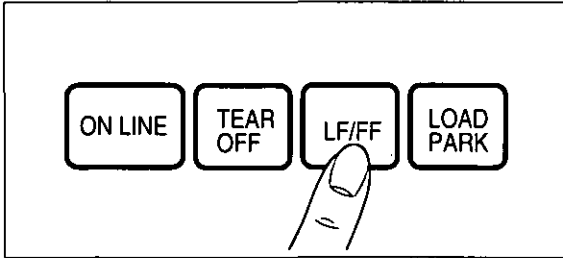

With paper installed, pressing **LF/FF** once advances the paper one line.

### Form Feed

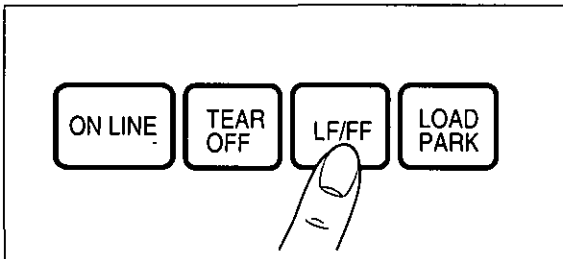

With paper installed, holding **LF/FF** moves the printhead to the center and advances the paper to the top of the next page.

### Micro Line Feed

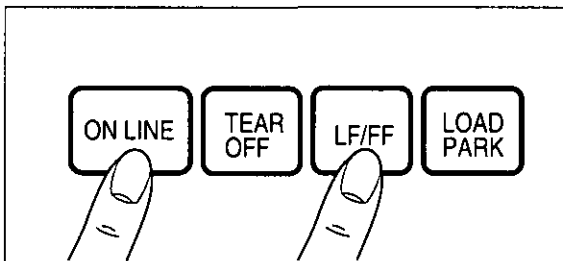

With paper installed, while pressing **ON LINE**, press **LF/FF** once to advance the paper one micro line ( $1/180''$ ). Holding the switches will advance the paper continuously until you release the switches. Using the Micro Line Feed within 5" from the top of your paper automatically stores the position as the Top of Form.

### Reverse Micro Line Feed

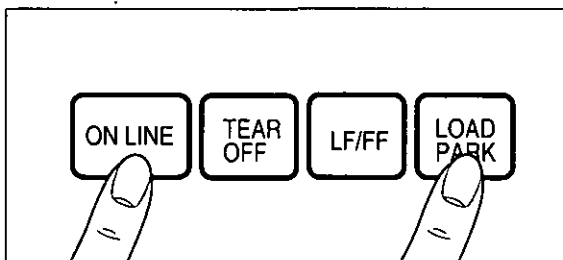





With paper installed, while pressing **ON LINE**, press **LOAD/PARK** once to reverse the paper one micro line ( $1/180''$ ). Holding the switches will reverse the paper continuously until you release the switches. Using the Reverse Micro Line Feed within 5" from the top of your paper automatically stores the position as the Top of Form.

#### Note:

- When pressing **LF/FF**, the amount of paper which is fed is determined by the current setting for lines per inch as specified by the Setup Disk, control panel (Initial Setup Mode) or your application software.
- Reverse Micro Line Feed is not recommended when the paper is fed through the bottom or front in Pull Tractor Mode. Paper may not feed properly and print quality may not be optimum.



## Top of Form Function (TOF SET)

This printer has a Top of Form (TOF) function which stores the first print line position and loads the paper to the designated position automatically. The first print line position will be stored even after the power is turned off. Additionally, the printer can store 3 different Top of Form positions depending on the paper feed method [fanfold paper-rear feed (  ), fanfold paper-bottom/front feed (  ) and single sheets and envelopes-top feed (  ) including the optional Cut Sheet Feeder (KX-P38)].

You can adjust the Top of Form position by using the Setup Disk (  P. 28~39), or using Micro Line Feed or Reverse Micro Line Feed within 5" from the top of your paper.

### Note:

- Do not rotate the platen knob, otherwise the printer will not be able to count the number of lines.
- When setting TOF for fanfold paper, all adjustments must be made on the first sheet. If you wish to change the setting after advancing additional sheets you must first park then reload the paper.

- 1 If necessary, redefine the page length of the paper you are using through the Setup Disk (  P. 28~39), control panel (  P. 47~49) or your application software (  P. 52~54).**

A page is defined by setting the page length through the Initial Setup mode (via the Setup Disk or through the control panel) or the Software command.

- 2 Micro Line Feed**

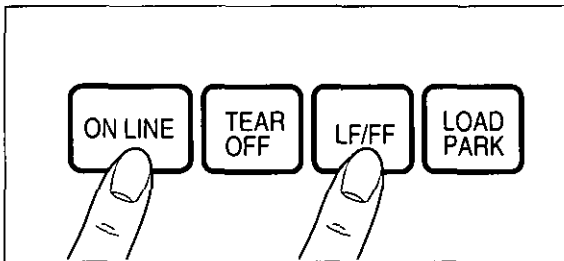

While pressing **ON LINE**, press **LF/FF**.

This advances the paper one micro line ( $1/180''$ ). Holding the switches will advance the paper continuously until you release the switches.

### Reverse Micro Line Feed

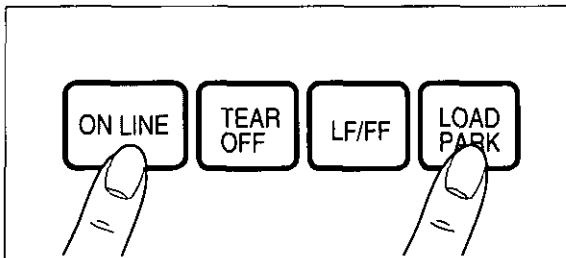

While pressing **ON LINE**, press **LOAD/PARK**.

This reverses the paper one micro line ( $1/180''$ ). Holding the switches will reverse the paper continuously until you release the switches. The printer cannot reverse the paper past the printable area.

- 3 At your desired position, release the switches.**

The paper position will be stored automatically as the new Top of Form position.

# Using the Control Panel

## Tear Off **TEAR OFF**

With fanfold paper installed through the rear paper path (available for Push Tractor Mode only), this function allows you to advance your paper to the tear position. After tearing off the page you can return your paper to the first print line by pressing **TEAR OFF** again. If **TEAR OFF** is not pressed a second time, the printer will automatically reverse to the first print line upon receiving data from the computer.

1

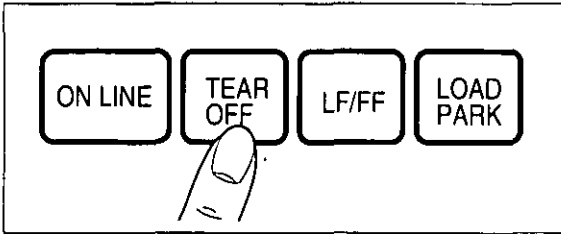

Press **TEAR OFF** to advance the paper to the tear bar.

2

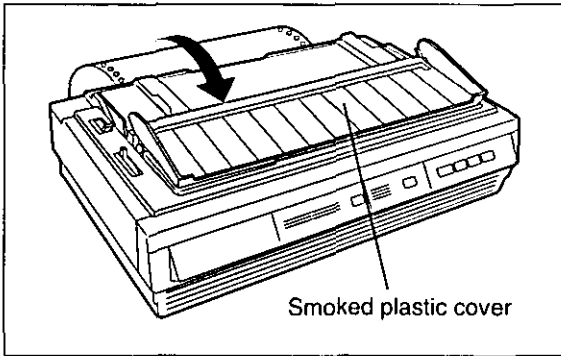

Fold forward the smoked plastic cover.

3

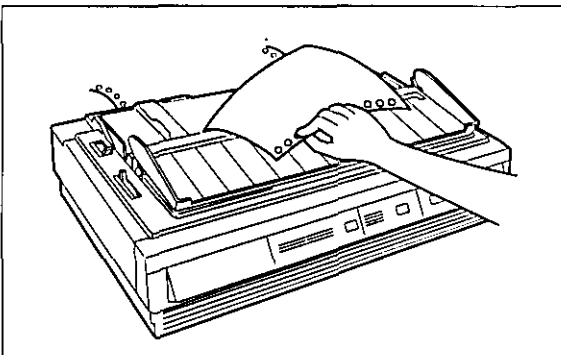

Tear off the page.

4

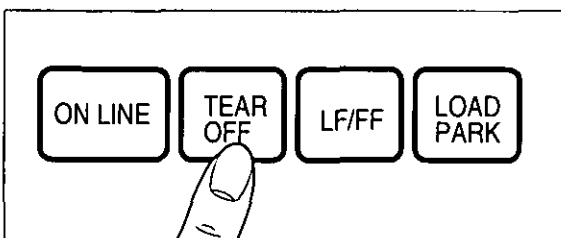

Press **TEAR OFF** to reverse the paper back to the first print line.

5

Fold back the smoked plastic cover.

## Paper Parking **LOAD/PARK**

This function moves the fanfold paper fed through the rear paper path (Push Tractor Mode) to the park position, enabling you to use single sheets or envelopes without removing or wasting your fanfold paper.

**1** Tear off the printed page(s) of the fanfold paper being used.

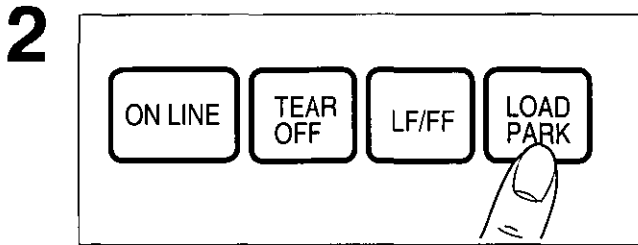

Press **LOAD/PARK** to reverse the fanfold paper to the park position.

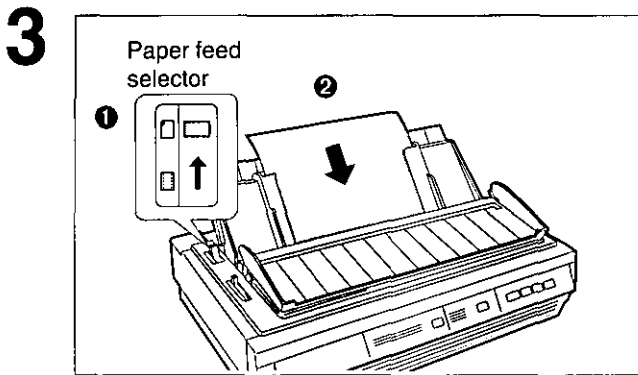

**1** Move the paper feed selector to “” (Friction Mode).

**2** Load single sheets or envelopes. (See P. 23 “Single Sheets and Envelopes”)

When you are finished printing, remove the sheet (or envelope) from the printer.

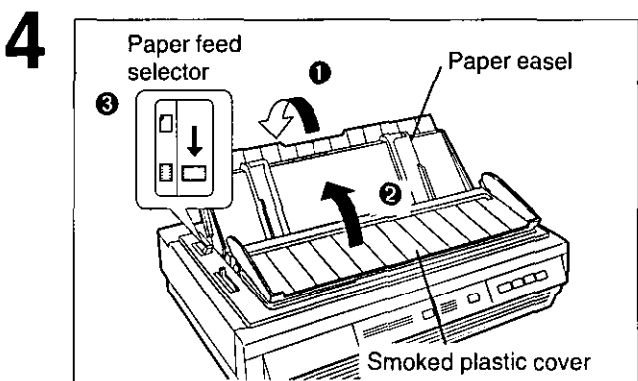

**1** Lower the paper easel.

**2** Fold back the smoked plastic cover.

**3** Move the paper feed selector to “” (Tractor Mode).

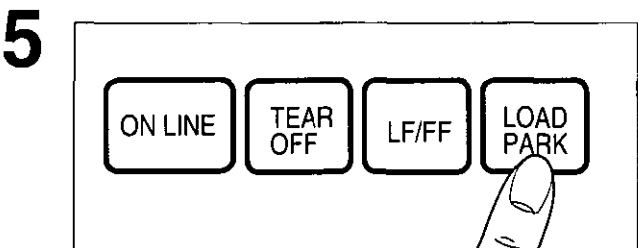

Press **LOAD/PARK** to reload the fanfold paper to the first print line.

## Paper Out Detector

Your printer has a paper out detector. When an out of paper condition occurs, printing stops, the printer goes to the OFF LINE mode, and the PAPER OUT indicator starts blinking. To continue printing to the end of the current page, follow the steps below.

1

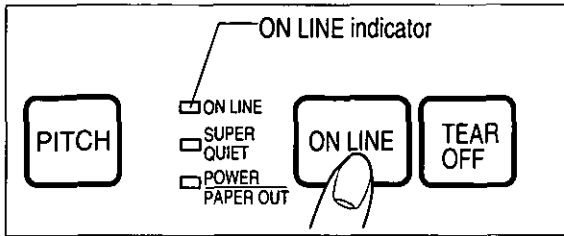

Press **ON LINE** repeatedly until the page is completed.

2

Install the new paper. ( P. 16-24)

3

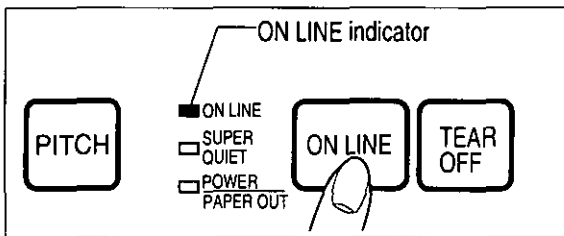

If the ON LINE indicator is not lit, press **ON LINE** .

**Note:**

- When the PAPER OUT DETECT is set to ON, printing stops at 0.5" from the bottom of the paper.
- The paper out detector can be disabled through the Setup Disk. ( P. 30)

## Initial Setup Mode

The following features (items) can be set in the Initial Setup mode through the Control Panel; Emulation, Auto Line Feed, Graphic Direction, Page Length and the optional Cut Sheet Feeder Mode, if optional KX-P38 is installed. These features can also be set using the Setup Disk.  
( P. 28)

### Setting the Printer Setup Mode

- 1 Load a sheet of paper ( P. 16~24), and turn the power off.

2

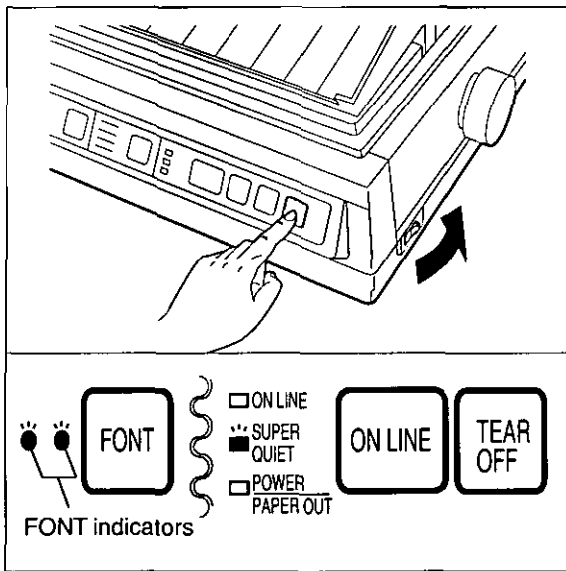

- To enter the Initial Setup mode  
While pressing **LOAD/PARK** , turn the power on.

Both FONT indicators and the Super Quiet indicator will be blinking.  
The current settings will be printed automatically.

3

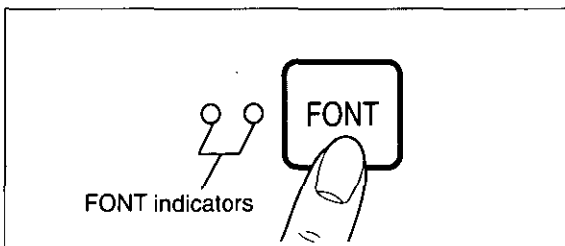

- Selecting the Item  
Press and release **FONT** .

Each time you press **FONT** , you will advance to the next item. Select the desired item according to the status of the FONT indicators (on, off, blinking).  
( P. 48)

4

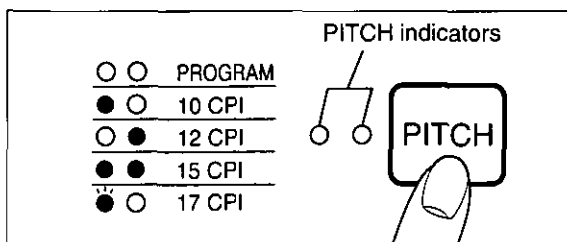

- Setting the Item's status  
Press and release **PITCH** .

The item's status will change each time you press **PITCH** . ( P. 48)

To change additional settings, repeat steps 3 and 4.

# Using the Control Panel

**Emulation:** Press **FONT** once.

Epson mode → Press **PITCH** → IBM mode



**Auto Line Feed:** Press **FONT** twice.

Off → Press **PITCH** → On



**Cut Sheet Feeder Mode:** Press **FONT** 3 times.

Off → Press **PITCH** → On

[This setting is only necessary when the optional Cut Sheet Feeder (KX-P38) is installed.]



**Graphic Direction:** Press **FONT** 4 times.

Uni directional → Press **PITCH** → Bi directional



**Page Length:** Press **FONT** 5 times.

11" → Press **PITCH** → 12"



Press **PITCH** → 11 2/3" (11.67")



Press **PITCH** → 14"



Press **PITCH** → 8"



Press **PITCH** → 8.5"



FONT/PITCH indicators condition:

● = light is lit

○ = light is out

◐ = light is blinking



5

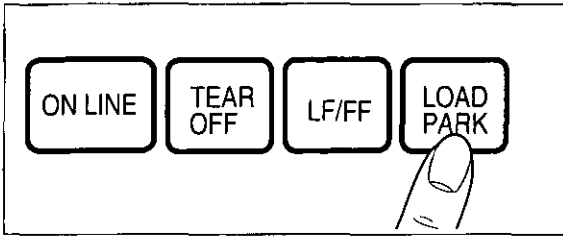

► To exit the Initial Setup mode  
Press **LOAD/PARK** .

FONT indicators will go off and the current conditions will print.

## Setting the Serial Setup Mode (Only when the KX-PS14 is installed)

Only when the KX-PS14 (Serial Interface Board) is installed, the following items can be set in the Serial Setup mode through the Control Panel. You can select and change the desired item according to the status of the FONT/PITCH indicators.

1 Load a sheet of paper ( P. 16~24), and turn the power off.

2

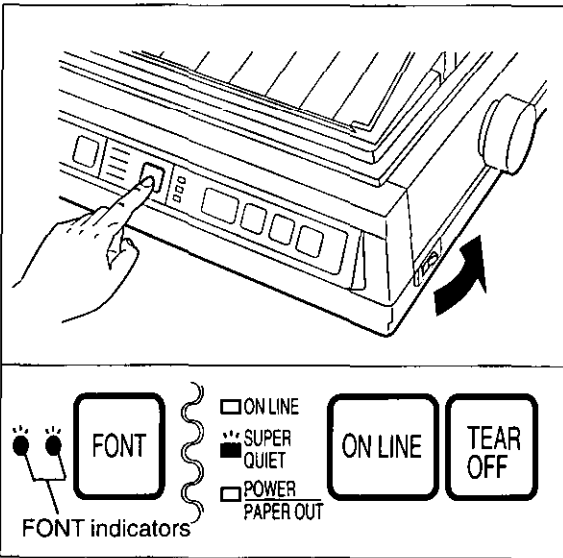

► To enter the Serial Setup mode  
While pressing **PITCH** , turn the power on.

Both FONT indicators and the Super Quiet indicator will be blinking. The current settings will be printed automatically.

3

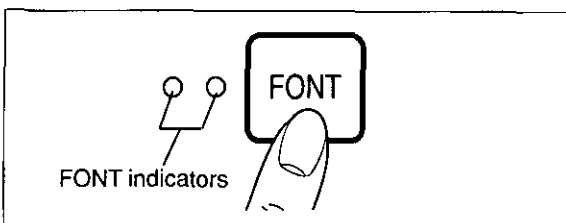

► Selecting the Item  
Press and release **FONT** .

Each time you press **FONT** , you will advance to the next item. Select the desired item according to the status of the FONT indicators (on, off, blinking). ( P. 50)

## 4

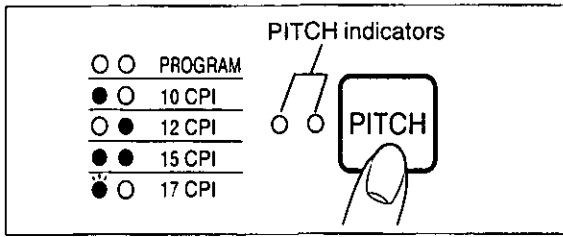

### ► Setting the Item's status

Press and release **PITCH** .

The item's status will change each time you press **PITCH** . See the table below to verify desired status.

To change additional settings, repeat steps 3 and 4.

ITEM	Setting	Press FONT key	FONT indicators	Press PITCH key	PITCH indicators
Print Current Setup Condition	—	—	● ●	—	○ ○
Interface	Parallel	once	○ ●	*1 ↓ ↑	○ ○
	Serial		○ ●	○ ●	
Data Length	8 bit	twice	● ○	*1 ↓ ↑	○ ○
	7 bit		● ○	○ ●	
Baud Rate	9600	3 times	● ●	*1 ↓	○ ○
	300				○ ●
	600				● ○
	1200				● ●
	2400				○ ●
	4800				● ○
Parity	None	4 times	○ ●	*1 ↓	○ ○
	Ignore				○ ●
	Odd				● ○
	Even				● ●
Protocol	DTR	5 times	● ○	*1 ↓ ↑	○ ○
	X/ON-X/OFF		○ ●		
S.D.T.	128 byte	6 times	● ●	*1 ↓ ↑	○ ○
	512 byte		○ ●		
R.D.T.	S.D.T.+128 byte	7 times	● ●	*1 ↓ ↑	○ ○
	S.D.T.+256 byte		○ ●		
Signal Polarity	MARK	8 times	○ ○	*1 ↓ ↑	○ ○
	SPACE		○ ●		

FONT/PITCH indicators condition:

● =light is lit      ○ =light is out      ● =light is blinking

\*1 The item's status will change each time you press **PITCH** .

## 5

### ► To exit the Serial Setup mode

Press **LOAD/PARK** .

FONT indicators will go off and the current conditions will print.

## Returning All Current Settings to the Factory Settings

This procedure will reset ALL settings to the original factory settings. This includes those settings made through the Setup Disk.

Follow the instructions below:

If paper is loaded, you will automatically get a printout of the current settings.

**1**

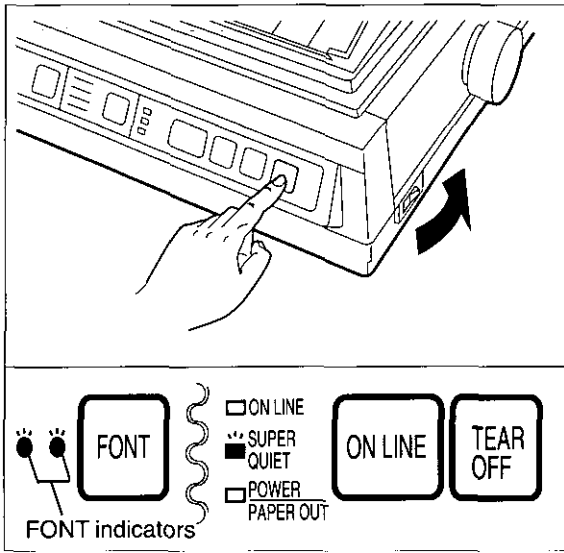

► To enter the Initial Setup mode

While pressing **LOAD/PARK**, turn the power on, then release.

Make sure that FONT indicators and the Super Quiet indicator are blinking.

**2**

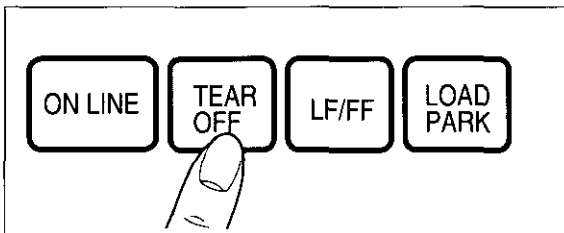

Press **TEAR OFF**.

All current settings will be reset to the Factory settings, and a beep will sound.

**3**

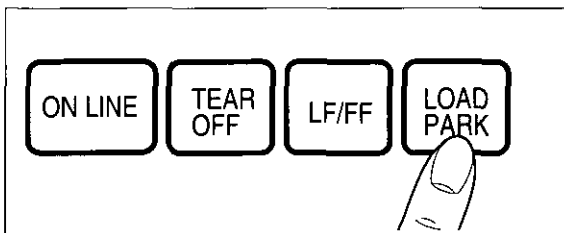

► To exit the Initial Setup mode

Press **LOAD/PARK**.

If paper is installed, a printout will verify the current setting.

# Command Reference Program (Using the Setup Disk)

The Command Reference program allows you to access a detailed explanation of each software command on the screen. Each displayed explanation can be printed out if required.

Before using the Setup Disk, it is recommended that you make a back-up copy and store the original in a safe place.

**Note:**

- Use the DISKCOPY command of the operating system to make a back-up copy. Refer to your DOS manual for further information.
- You may find it convenient to install the Setup Disk programs directly onto your C Drive, rather than reading them from the Setup Disk each time a change is necessary. Either method is acceptable.

To perform an automatic installation of the Setup Disk files onto your C Drive, refer to page 32.

## 1 Insert your Setup Disk into either drive A or B.

<For DOS>

2 Type A: (or B:) and Press **Enter** .

3 Type CMDREF

4 Press **Enter** .

5 The first screen is an introduction to the operation of the Setup Disk. Please read through it and press any key to continue. (If your display is monochrome, press "M" key.)

Screen 1 will be displayed.

6 Press **↑** or **↓** .

Select an emulation.

<For WINDOWS>

2 Select **Run** from the File menu.

3 Type A:\CMDREF (or B:\CMDREF)

4 Click **OK** (or Press **Enter** ).

Screen 1

```
<<Panasonic KX-P3626 command reference utility (xxxxxxxxxx)>>
  -- SELECT EMULATION --
-----
      [EPSON]
      IBM

-----
[↑]/[↓]      : Select emulation
[Enter]      : Set emulation
[E]          : Exit to DOS
```

**Note:**

- You can proceed through the Command Reference program using a computer mouse or your keyboard. Highlight the desired item and click the left mouse button, or follow the directions on your screen for keyboard operation.
- There is a list of proportional spacing tables after the software commands list. If you want to see a proportional spacing table, select your desired table and press **Enter** .

## 7 Press **Enter** .

The emulation will be set and screen 2 will be displayed.

### Screen 2

```

<< Panasonic KX-P3626 command reference utility (xxxxxxxxxx) >>
  -- SELECT COMMAND --      (EPSON)
=====
FONT SELECTION
{ ESC+'X'+n                Selects print quality
  ESC+'k'+n                Selects print font style
  ESC+'S'+0                Selects superscript printing
  ESC+'S'+1                Selects subscript printing
  ESC+'T'                  Releases sub/superscript printing
  ESC+'X'+m+n1+n2         Selects font by pitch and point

CHARACTER PITCH SELECTION
  ESC+'P'                  Sets pica pitch (10 cpi) printing
  ESC+'M'                  Sets elite pitch (12 cpi) printing
  ESC+'g'                  Sets micron pitch (15 cpi) printing
  SI or ESC+SI             Sets compressed pitch (17 cpi) printing
  DC2                      Releases compressed pitch (17 cpi) printing
  ESC+'p'+n                Sets/Releases proportional spacing
=====
[↑]/[↓]                   : Select command
[Pg.Up]/[Pg.Down]        : Go to previous/next category
[Enter]                  : View command description
[Esc]                    : SELECT EMULATION mode
[E]                       : Exit to DOS          [P] : Print Command List
  
```

[↑]/[↓]	Moves the cursor one line up/down
[Pg.Up] / [Pg.Down]	Moves the cursor to the first command of the previous/next item
[Enter]	Displays the explanation of the command
[Esc]	Returns to screen 1
[E]	Exits to DOS
[P]	Prints Command List

If you want to print the command list with parameters, press **P** and press **Y** .

"Y": The command list with parameters will be printed.

"N": The display will return to screen 2.

### Screen 3

```

<< Panasonic KX-P3626 command reference utility (xxxxxxxxxx) >>
  -- SELECT COMMAND --      (EPSON)
=====
FONT SELECTION
{ ESC+'X'+n                Selects print quality
  ESC+'k'+n                Selects print font style
  ESC+'S'+0                Selects superscript printing
  ESC+'S'+1                Selects subscript printing
  ESC+'T'                  Releases sub/superscript printing
  ESC+'X'+m+n1+n2         Selects font by pitch and point

CHARACTER PITCH SELECTION
  ESC+'P'                  Sets pica pitch (10 cpi) printing
  ESC+'M'                  Sets elite pitch (12 cpi) printing
  ESC+'g'                  Sets micron pitch (15 cpi) printing
  SI or ESC+SI             Sets compressed pitch (17 cpi) printing
  DC2                      Releases compressed pitch (17 cpi) printing
  ESC+'p'+n                Sets/Releases proportional spacing
=====
Print command list? (Y/N)
  Yes   No
  
```

## 8 Press **Pg.Up** / **Pg.Dn** or **↑** / **↓** .

Select a command.

## 9 Press **Enter** .

Screen 4 will show the detailed explanation of the command.

If you want to exit the Command Reference program, go to step 10.

### Screen 4

```

<< Panasonic KX-P3626 command reference utility (xxxxxxxxxx) >>
ESC+x+n Selects print quality [EPSON]
-----
<PRINT QUALITY>
Selects print quality.

Name:   ESC      x      n
Dec.:   27      120   n
Hex.:   1B      78    n

Comments:
* The following values of n can be used:
  n=0: Draft font
  n=1: LQ font
  n=2: SLQ mode (Roman 5, 10, 6 and 12 CPI fonts only)

----- END -----
[↑]/[↓]      : Text scroll-down/up
[Pg.Up]/[Pg.Down] : Go to previous/next command
[Esc]        : SELECT COMMAND mode
[Enter]      : Print current command description
[E]          : Exit to DOS
    
```

[↑]/[↓]	Scrolls the text one line down/up
[Pg.Up]/[Pg.Down]	Displays the explanation of previous/next command
[Enter]	Prints the detailed explanation of the command
[Esc]	Returns to screen 2
[E]	Exits to DOS

If you want to print this explanation, press **Enter** again and press **Y** .

"Y": The explanation will be printed.  
 "N": The display will return to screen 3.

### Screen 5

```

<< Panasonic KX-P3626 command reference utility (xxxxxxxxxx) >>
ESC+x+n Selects print quality [EPSON]
-----
<PRINT QUALITY>
Selects print quality.

Name:   ESC      x      n
Dec.:   27      120   n
Hex.:   1B      78    n

Comments:
* The following values of n can be used:
  n=0: Draft font
  n=1: LQ font
  n=2: SLQ mode (Roman 5, 10, 6 and 12 CPI fonts only)

----- END -----

Print current command description? (Y/N)
    Yes      No
    
```

## 10 Press **E** .

You have exited the Command Reference program.

# Periodic Maintenance/Troubleshooting

## Periodic Maintenance

The printer does not require any routine maintenance. However, reasonable care of the printer will extend its life. The following periodic measures are recommended:

- Cleaning the unit is the most important action the user can perform. The frequency of cleaning is dependent upon the environment.
  - Turn the power off.
  - Clean the case and covers with a soft cloth. Use any mild commercial cleaner on the cloth, do not spray directly on to the printer.
  - Open the top cover and remove the smoked plastic cover. Vacuum or dust the inside area of the unit. Be very careful not to damage the printhead ribbon cable or the carriage drive belt.
 

**Caution:** The printhead may be hot, use caution when cover is open.
  - The platen should be cleaned with denatured alcohol only.
  - The carriage guide bar can be lubricated with a very light oil. Contact your Authorized Panasonic Service Center for advice on lubrication.

### Ribbon cassette:

**Note:** If the ribbon begins to catch, snag, or tear from the printhead, your printer requires servicing.

## Troubleshooting

Most problems associated with the printer can be traced to improper setup, installation, or cabling. The following table will assist you in identifying and correcting some of the more common problems. If you need additional help, contact the store from which the unit was purchased or the Panasonic technical support number found on the inside back cover of this manual.

Symptom	Possible Cause	Probable Solution
Ink smears	Head gap lever is not in the proper position	Move the lever toward the (+) position until ink does not smear ( P. 10)
Printout is faint	Head gap lever is not in proper position	Adjust the lever to the proper position ( P. 10)
Carriage moves but there is no printing	Ribbon is not installed correctly	Re-insert ribbon ( P. 12~14)
Paper out detector inoperative	PAPER OUT DETECT is OFF	Set PAPER OUT DETECT to ON ( P. 30, 32~39)
Paper slips around platen	Paper feed selector is set to " " ( )	Set selector to " " ( )
Printer does not power up	No AC power	Check power cord ( P. 11)
Power is on but printer does not print	Printer is not ON LINE	Press ON LINE
	Interface cable is not properly connected	Secure connection ( P. 11)
	Out of paper	Install new paper ( P. 16~24, 46)
	Printhead has become overheated	Allow the printhead some time to cool down. The printer will automatically resume printing
	Smoked plastic cover is open	Ensure cover is completely closed

(Continued)

# Periodic Maintenance/Troubleshooting

Symptom	Possible Cause	Probable Solution
Carriage stops moving, all indicators start blinking	Path of printhead is blocked	Turn the power off, clear the path. Turn the power back on to resume printing
Paper wrinkles when using tractor feed	No reverse tension on paper	Set paper supply lower than printer
Buzzer sounds when installing single sheet	Paper feed selector is set to " " (Tractor icon)	Set paper feed selector to " " (Sheet icon)
Printer cannot load single sheet through the top	CSF MODE is ON	Set CSF MODE to OFF when not using the cut sheet feeder ( P. 30, 32~39, 47~49)
	Paper feed selector is set to " " (Tractor icon)	Set paper feed selector to " " (Sheet icon)
Cut Sheet Feeder option (KX-P38) is installed but does not work	CSF MODE is OFF	Set CSF MODE to ON ( P. 30, 32~39, 47~49)
Unexpected characters appear in printing	EMULATION is set incorrectly	Check printer driver of your software package and set EMULATION accordingly ( P. 28, 32~39, 47~49)
Printout is double-spaced	AUTO LF is ON	Set AUTO LF to OFF ( P. 30, 32~39, 47~49)
Keeps printing on the same line	Computer is not sending a LF command	Set AUTO LF to ON ( P. 30, 32~39, 47~49)
Wrong character set is printed	Wrong character set is selected	Set the character set as required ( P. 29, 32~39)
Cannot print ASCII characters with code above 127	Data length is set incorrectly	Set data length as required ( P. 31, 32~39, 49~50)
Fanfold paper is jamming	Paper not installed correctly in tractor	Set paper feed selector to " " (Sheet icon) and rotate platen knob to easily remove jammed paper Reinstall paper correctly into tractor ( P. 16~24)
KX-PS14 (serial interface board) is installed but cannot print	I/F is set to PARALLEL	Set I/F to SERIAL ( P. 31, 49~50)
Cannot use parallel interface when installing serial interface board	KX-PS14 I/F is set to SERIAL	Set I/F to PARALLEL ( P. 31, 49~50)
	KX-PS13 Parallel interface cannot be used when a KX-PS13 is installed	Remove KX-PS13 when using parallel interface



# Initialization/Hex Dump

## Initialization

The printer is initialized under the following conditions:

- the AC power is turned on
- the  $\overline{\text{PRIME}}$  signal is received
- the RESET PRINTER command is received
- the clear buffer function is used

When the printer is initialized, the following conditions are set:

- the print buffer is cleared
- the receive buffer is cleared (not cleared by RESET PRINTER command)
- the download character buffer is cleared (not cleared by  $\overline{\text{PRIME}}$  signal in IBM Proprinter XL24E mode or by RESET PRINTER command)
- the initial setup modes are read and set
- horizontal tabs are set every 8 columns
- vertical tab settings are cleared
- all modes set by control and escape commands will be cleared
- present form position is designated as Top of Form
- the self test mode is cleared
- the control panel settings are read and set
- control panel settings are not changed by  $\overline{\text{PRIME}}$  signal or RESET PRINTER command\*
- the printhead goes to the home position

\* Some software packages send  $\overline{\text{PRIME}}$  signal at the beginning of their programs. Print modes set by the Control Panel will not change.

## User Clear Function

This function initializes the printer from the Control Panel. This feature is very useful when you want to clear the receive buffer (information recently sent from the computer and is currently printing) without changing the Control Panel settings.

1. Press **ON LINE** to stop the printing and enter the OFF LINE mode.
2. While pressing **ON LINE**, press **FONT** to clear the data in the receive buffer.
3. Press **ON LINE** to re-enter the ON LINE mode.

## Hex Dump

In this mode, all data received from the computer is printed in hex code instead of the normal ASCII characters. Function codes for the printer (CR, LF, HT, etc.) are not executed. This mode is very useful to debug programs.

### To enter the Hex Dump mode:

While pressing **FONT**, turn the power on.

### To release the Hex Dump mode:

Turn the power off, then back on.

# Printer Specifications

Power requirements:	Refer to the nameplate located on the rear of the printer.																																														
Frequency:																																															
Current:																																															
Interface:	Centronics parallel RS-232C/serial interface board [KX-PS14, KX-PS13] (option)																																														
Print fonts:	3 Draft (Pica, Elite, Micron) 7 Letter Quality (Courier, Bold PS, Prestige, Script, Sans Serif, Roman, OCR-B) 1 Super Letter Quality (Roman) 6 Scalable Fonts (Courier, Bold PS, Prestige, Script, Sans Serif, Roman)																																														
Software emulation:	Epson LQ-1170 IBM Proprinter XL24E																																														
Buffer:	40K (standard)																																														
Character sets:	96 ASCII characters, 96 Italic ASCII characters, 33 International characters — 14 countries & LEGAL Set 38 Multilingual characters 158 IBM-PC special characters																																														
Dot configuration:	<table border="0"> <tr> <td></td> <td style="text-align: center;"><b>Draft</b></td> <td style="text-align: center;"><b>LQ</b></td> <td style="text-align: center;"><b>SLQ</b></td> </tr> <tr> <td><b>Matrix</b> (Hor. × Ver.)</td> <td style="text-align: center;">9 × 24</td> <td style="text-align: center;">30 × 24</td> <td style="text-align: center;">30 × 48</td> </tr> <tr> <td><b>Dot pitch</b> (Hor.)</td> <td style="text-align: center;">1/120" (0.21 mm)</td> <td style="text-align: center;">1/360" (0.07 mm)</td> <td style="text-align: center;">1/360" (0.07 mm)</td> </tr> <tr> <td>(Ver.)</td> <td style="text-align: center;">1/180" (0.14 mm)</td> <td style="text-align: center;">1/180" (0.14 mm)</td> <td style="text-align: center;">1/360" (0.07 mm)</td> </tr> </table>				<b>Draft</b>	<b>LQ</b>	<b>SLQ</b>	<b>Matrix</b> (Hor. × Ver.)	9 × 24	30 × 24	30 × 48	<b>Dot pitch</b> (Hor.)	1/120" (0.21 mm)	1/360" (0.07 mm)	1/360" (0.07 mm)	(Ver.)	1/180" (0.14 mm)	1/180" (0.14 mm)	1/360" (0.07 mm)																												
	<b>Draft</b>	<b>LQ</b>	<b>SLQ</b>																																												
<b>Matrix</b> (Hor. × Ver.)	9 × 24	30 × 24	30 × 48																																												
<b>Dot pitch</b> (Hor.)	1/120" (0.21 mm)	1/360" (0.07 mm)	1/360" (0.07 mm)																																												
(Ver.)	1/180" (0.14 mm)	1/180" (0.14 mm)	1/360" (0.07 mm)																																												
Maximum number of characters per line (cpl):	<table border="0"> <tr> <td><b>Font</b></td> <td colspan="3" style="text-align: right;"><b>Print line size 8" / 13.6"</b></td> </tr> <tr> <td>Pica [10 cpi (characters per inch)]</td> <td></td> <td></td> <td style="text-align: right;">80 / 136 cpl</td> </tr> <tr> <td>Elite (12 cpi)</td> <td></td> <td></td> <td style="text-align: right;">96 / 163 cpl</td> </tr> <tr> <td>Micron (15 cpi)</td> <td></td> <td></td> <td style="text-align: right;">120 / 204 cpl</td> </tr> <tr> <td>Compressed (17 cpi)</td> <td></td> <td></td> <td style="text-align: right;">137 / 233 cpl</td> </tr> <tr> <td>Elite compressed (20 cpi)</td> <td></td> <td></td> <td style="text-align: right;">160 / 272 cpl</td> </tr> <tr> <td>Pica elongated (5 cpi)</td> <td></td> <td></td> <td style="text-align: right;">40 / 68 cpl</td> </tr> <tr> <td>Elite elongated (6 cpi)</td> <td></td> <td></td> <td style="text-align: right;">48 / 81 cpl</td> </tr> <tr> <td>Micron elongated (7.5 cpi)</td> <td></td> <td></td> <td style="text-align: right;">60 / 102 cpl</td> </tr> <tr> <td>Compressed elongated (8.5 cpi)</td> <td></td> <td></td> <td style="text-align: right;">68 / 116 cpl</td> </tr> <tr> <td>Elite compressed elongated (10 cpi)</td> <td></td> <td></td> <td style="text-align: right;">80 / 136 cpl</td> </tr> </table>			<b>Font</b>	<b>Print line size 8" / 13.6"</b>			Pica [10 cpi (characters per inch)]			80 / 136 cpl	Elite (12 cpi)			96 / 163 cpl	Micron (15 cpi)			120 / 204 cpl	Compressed (17 cpi)			137 / 233 cpl	Elite compressed (20 cpi)			160 / 272 cpl	Pica elongated (5 cpi)			40 / 68 cpl	Elite elongated (6 cpi)			48 / 81 cpl	Micron elongated (7.5 cpi)			60 / 102 cpl	Compressed elongated (8.5 cpi)			68 / 116 cpl	Elite compressed elongated (10 cpi)			80 / 136 cpl
<b>Font</b>	<b>Print line size 8" / 13.6"</b>																																														
Pica [10 cpi (characters per inch)]			80 / 136 cpl																																												
Elite (12 cpi)			96 / 163 cpl																																												
Micron (15 cpi)			120 / 204 cpl																																												
Compressed (17 cpi)			137 / 233 cpl																																												
Elite compressed (20 cpi)			160 / 272 cpl																																												
Pica elongated (5 cpi)			40 / 68 cpl																																												
Elite elongated (6 cpi)			48 / 81 cpl																																												
Micron elongated (7.5 cpi)			60 / 102 cpl																																												
Compressed elongated (8.5 cpi)			68 / 116 cpl																																												
Elite compressed elongated (10 cpi)			80 / 136 cpl																																												
Printing speed [characters per second (cps)]:	<table border="0"> <tr> <td></td> <td style="text-align: center;"><b>Micron</b></td> <td style="text-align: center;"><b>Elite</b></td> <td style="text-align: center;"><b>Pica</b></td> </tr> <tr> <td><b>Draft</b></td> <td style="text-align: center;">300 cps</td> <td style="text-align: center;">240 cps</td> <td style="text-align: center;">200 cps</td> </tr> <tr> <td><b>LQ</b></td> <td style="text-align: center;">100 cps</td> <td style="text-align: center;">80 cps</td> <td style="text-align: center;">66 cps</td> </tr> <tr> <td><b>SLQ</b></td> <td></td> <td style="text-align: center;">40 cps</td> <td style="text-align: center;">33 cps</td> </tr> </table>				<b>Micron</b>	<b>Elite</b>	<b>Pica</b>	<b>Draft</b>	300 cps	240 cps	200 cps	<b>LQ</b>	100 cps	80 cps	66 cps	<b>SLQ</b>		40 cps	33 cps																												
	<b>Micron</b>	<b>Elite</b>	<b>Pica</b>																																												
<b>Draft</b>	300 cps	240 cps	200 cps																																												
<b>LQ</b>	100 cps	80 cps	66 cps																																												
<b>SLQ</b>		40 cps	33 cps																																												
Printing direction:	Unidirectional / Bidirectional (user selectable)																																														
Line feed time:	Approx. 81 msec [with 1/8 inch (4.2 mm) line feeding] 2.5 ips at Form Feed																																														
Paper feed:	Push/Pull (user selectable) tractor feed (with fanfold paper) Friction feed (with single sheets or envelopes)																																														

(Continued)

# Printer Specifications

Noise level:	Less than 46.5 dB(A) in Normal Mode Less than 43.5 dB(A) in Super Quiet Mode
Operating environment:	Temperature: 10°C~35°C {50°F~95°F} Humidity: 20~80% RH (Please allow the printer to stabilize at room temperature within the operating temperature range before operation)
Power consumption:	MAX – 160 W Stand by – 10 W Self test – 46 W
Storage environment:	Temperature: -20°C~60°C {-4°F~140°F} Humidity: 10~90% RH
Head service life:	Approx. 200 million strokes in DRAFT mode
Ribbon:	Endless fabric ribbon Black ribbon cassette KX-P170: Life expectancy (in DRAFT mode / rolling ASCII) Approx. 5 million characters
Detectors:	Paper out detector Overheat detector Overload detector Cover open sensor
Dimensions:	590 (W) × 407 (D) × 172 (H) mm {23.2" × 16.0" × 6.8"}
Mass {Weight}:	Approx. 14.0 kg {30.8 lbs}

# Paper Specifications

Paper which may be used with this unit must be within the specifications provided below.

## Fanfold Paper

**Width:** 4 ~ 15.5 inches (102 ~ 394 mm)

**Quality and number of sheets:**

Type of paper	Sheets	Weight			
		lbs		g/m <sup>2</sup>	
		push	pull	push	pull
Fine-quality paper	1	16 ~ 24	14 ~ 24	60 ~ 90	53 ~ 90
Non-carbon	2 ~ 5	11 ~ 14 (17*)		41 ~ 53 (64*)	
Multi-layered with carbon	3	11 ~ 14 (17*)		41 ~ 53 (64*)	

(\* only for the last sheet)

**Note:**

- When using multipart fanfold paper especially in environments that have very high or low temperature and/or humidity, we recommend the use of the bottom feed pull mode to optimize paper handling and print quality.
- To insure optimum print quality, 16 ~ 22 lbs (60 ~ 82.5 g/m<sup>2</sup>) is recommended for graphic printing.
- In multi-layered paper with carbon, the carbon is equivalent to a sheet of paper.
- "Weight in pounds" represents the weight of 500 [17x22 inches (432x559 mm)] sheets.
- The printer will handle multipart forms up to 0.014 inch (0.36 mm) thick. Up to 5 copies of 14 lb. chemical release paper can be used.

## Single Sheet

**Width:** 4 ~ 16.5 inches (102 ~ 420 mm)

**Height:** 5 ~ 14.3 inches (127 ~ 363 mm)

**Weight in pounds (g/m<sup>2</sup>):** 14 ~ 24 lbs (53 ~ 90 g/m<sup>2</sup>)

**Note:**

- Paper should be within operating temperature and humidity ranges at least 24 hours prior to use.
- Due to letter head varying in paper weight and construction, we cannot guarantee print quality and paper handling for all types.

## Envelope

#6 and #10 size envelopes are recommended. Since envelopes vary in size, paper weight and construction, we cannot guarantee print quality and paper handling for all types of envelopes.

**Note:**

- To optimize print quality, printing should not occur in areas where the edges overlap.

**Printing Area**

**Fanfold Paper**

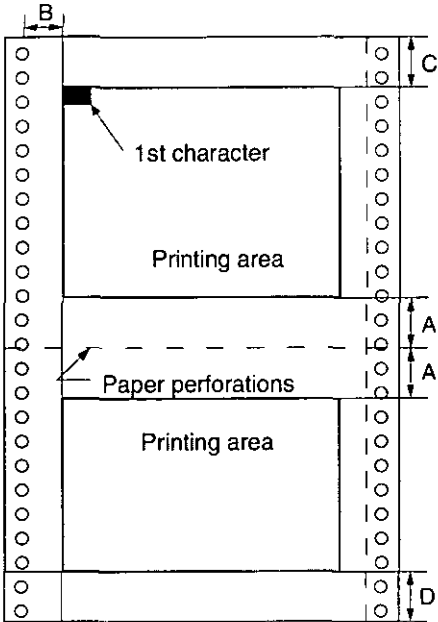

	Push	Pull
<b>A</b>	1" (25.4 mm)	
<b>B</b>	0.7" (17.8 mm)	
<b>C</b>	0.33" (8.38 mm)	5.7" (144.8 mm)
<b>D</b>	1" (25.4 mm)	

- A:** Value A indicates the area near the paper perforations where the quality may not be optimum.
- B:** Value B indicates the minimum distance between the sprockets and first printable character. (When the left tractor is set on the left end and the margin is set to 0.)
- C:** Value C indicates the area from the top edge of the paper to the top of the first printed character.
- D:** Value D indicates the position where paper out is detected and printing may not be optimum.

**Single Sheet and Envelope**

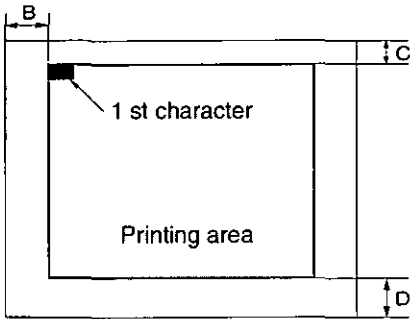

	Single Sheet and Envelope
<b>B</b>	1.5" (38 mm)
<b>C</b>	0.33" (8.38 mm)
<b>D</b>	1" (25.4 mm)

- B:** Value B indicates the minimum distance between the edge of the paper and the first printable character. (When the left paper guide is set to the left end and the margin is set to 0.)
- C:** Value C indicates the area from the top edge of the paper to the top of the first printed character.
- D:** Value D indicates the position where paper out is detected and printing may not be optimum. (When printing on envelopes, do not print on area where edges overlap. Print quality may not be optimum.)

## Parallel Interfacing

A method of transferring data from a computer to a printer through a parallel interface based on the Centronics standard.

### Specifications:

- data transfer speed: 1000 cps minimum
- synchronization: external STROBE pulse
- logic levels: TTL (Transistor-Transistor-Logic) levels
- handshaking: BUSY and  $\overline{\text{ACK}}$  signals
- connector type: 57-30360 (AMPHENOL) or equivalent
- cable: use a shielded cable (6'5"/1.95 meters) or less in length.

When the printer is processing data, the BUSY signal is high. The printer will not accept new data from the computer. After the processing is completed, the BUSY signal goes low. (The BUSY signal is also high when the printer is OFF LINE). When the busy signal occurs, the  $\overline{\text{ACK}}$  signal goes low indicating to the computer that the data has been processed and the printer is ready to accept more data. This handshaking routine occurs each time a character is sent to the printer.

	BUSY	SLCT	PO	ERROR
ON LINE	LOW	HIGH	LOW	HIGH
OFF LINE	HIGH	LOW	LOW	LOW
PAPER OUT	HIGH	LOW	HIGH	LOW

Printer status signals

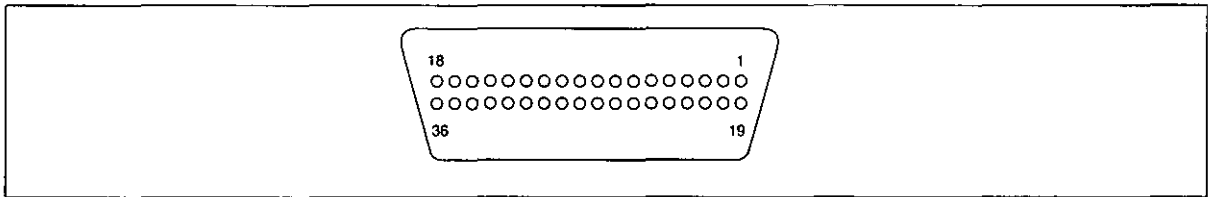

Parallel interface connector (printer side)

Signal pin	Return side pin	Signal	Direction
1	19	$\overline{\text{STB}}$	Input
2	20	DATA 1	
3	21	DATA 2	
4	22	DATA 3	
5	23	DATA 4	
6	24	DATA 5	
7	25	DATA 6	
8	26	DATA 7	
9	27	DATA 8	
10	28	$\overline{\text{ACK}}$	Output
11	29	BUSY	
12		PO	

Signal pin	Return side pin	Signal	Direction
13		SLCT	Output
14		$\overline{\text{AUTO FEED XT}}$	Input
15			
16		SG	
17		FG	
18		+5 V	Output
31	30	$\overline{\text{PRIME}}$	Input
32		$\overline{\text{ERROR}}$	Output
33		SG	
34			
35			
36		$\overline{\text{SLCT IN}}$	Input

Pin configuration (Parallel)

## Connector Pin Signals

### STB...STROBE

- This is a synchronizing input signal to read data into the printer.
- This signal is normally high. Data is read in when it is low.

### DATA1-DATA8

- These are the input signals which carry the 8 data bits of information.
- The signal is read in synchronization with the STROBE pulse. A high level indicates a logical "1".

### ACK...ACKNOWLEDGE

- This is an output signal to the computer indicating that the printer is ready to receive the next data. When the condition becomes true, the signal goes low.
- The ACK signal is automatically sent whenever the printer is switched ON LINE and the BUSY signal drops from high to low.

### BUSY

- This output signal indicates the status on which the printer cannot receive data.
- The signal is high under the following conditions:
  1. receive buffer full
  2. printer is processing data
  3. printer is OFF LINE
  4. printer is in an error condition

### PO...PAPER OUT

- This output signal indicates the absence of paper and goes high during a "Paper Out" condition.

### SLCT...SELECT

- This output signal is high in the ON LINE mode and low when OFF LINE.
- The printer enters the ON LINE mode:
  1. when the printer is turned on
  2. when PRIME is received
  3. when the RESET command is received
  4. when the ON LINE switch is pressed
- The printer enters the OFF LINE mode:
  1. when the printer is out of paper
  2. when the printer is switched OFF LINE

### AUTO FEED XT (AFXT)

- While this input signal is low, one line feed (LF) command will be added to each carriage return (CR).
- Auto LF setting in the FUNCTION mode can alter the response by the printer to an AFXT signal. If auto LF is ON, the printer will perform a CR+LF regardless of the level of the AFXT signal. When auto LF is OFF, automatic action is disabled.

### SG...SIGNAL GROUND

- The twisted pair return wires (pins 19-30) are connected to signal ground.

### FG...FRAME GROUND

- Frame ground is the same as chassis ground.

### +5V

- This is for evaluation only. It should not be used to supply power for external equipment.

### PRIME

- This input signal is normally high and goes low to reset the printer. It can be received anytime during printer operation.

### ERROR

- This output signal is normally high, and goes low when an error occurs. An error condition can be caused by:
  1. a "Paper Out" condition
  2. the printer is OFF LINE
  3. an overload condition exists

### SLCT IN

- This input signal is normally low, and goes high when using the Setup disk.

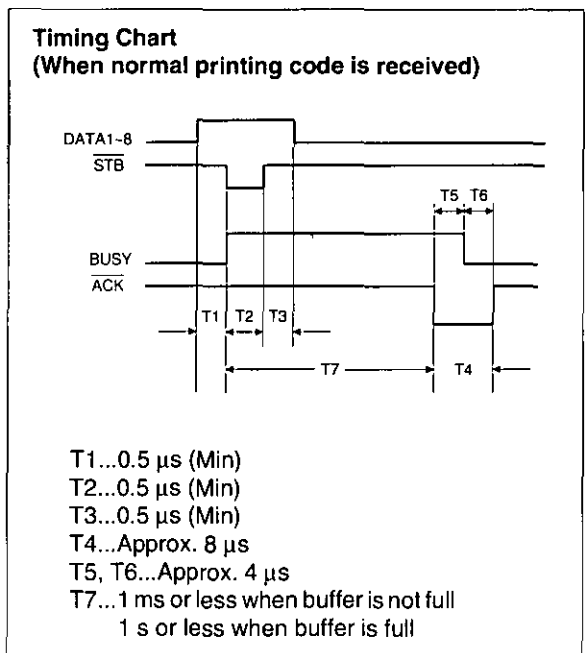

Timing diagram

# Character Set Tables

## Epson Italic Character Set (USA)

Dec.	0	16	32	48	64	80	96	112	128	144	160	176	192	208	224	240	
Hex.	0	1	2	3	4	5	6	7	8	9	A	B	C	D	E	F	
0	0	NUL	SP	0	•	P	'	p		SP	0	•	P	'	p		
1	1		DC1	!	!	A	O	a	q	DC1	!	!	A	O	a	q	
2	2		DC2	"	2	B	R	b	r	DC2	"	2	B	R	b	r	
3	3		DC3	#	3	C	S	c	s	DC3	#	3	C	S	c	s	
4	4		DC4	\$	4	D	T	d	t	DC4	\$	4	D	T	d	t	
5	5			%	5	E	U	e	u		%	5	E	U	e	u	
6	6			&	6	F	V	f	v		&	6	F	V	f	v	
7	7	BEL		'	7	G	W	g	w	BEL		'	7	G	W	g	w
8	8	BS	CAN	(	8	H	X	h	x	BS	CAN	(	8	H	X	h	x
9	9	HT	EM	)	9	I	Y	i	y	HT	EM	)	9	I	Y	i	y
10	A	LF		*	:	J	Z	j	z	LF		*	:	J	Z	j	z
11	B	VT	ESC	+	:	K	[	k	{	VT	ESC	+	:	K	[	k	{
12	C	FF		.	<	L	\	l		FF		.	<	L	\	l	
13	D	CR		-	=	M	]	m	}	CR		-	=	M	]	m	}
14	E	SO		.	>	N	^	n	~	SO		.	>	N	^	n	~
15	F	SI		/	?	O	_	o	DEL	SI		/	?	O	_	o	NUL

## Epson Graphic Character Set 2 (USA) PC437

Dec.	0	16	32	48	64	80	96	112	128	144	160	176	192	208	224	240
Hex.	0	1	2	3	4	5	6	7	8	9	A	B	C	D	E	F
0	0	NUL	SP	0	•	P	'	p	Ç	É	á	⋮	⋮	⋮	⋮	⋮
1	1		DC1	!	!	A	O	a	q	ü	æ	í	⋮	⋮	⋮	⋮
2	2		DC2	"	2	B	R	b	r	é	Æ	ó	⋮	⋮	⋮	⋮
3	3		DC3	#	3	C	S	c	s	á	ò	ú	⋮	⋮	⋮	⋮
4	4		DC4	\$	4	D	T	d	t	á	ò	ñ	⋮	⋮	⋮	⋮
5	5		§	%	5	E	U	e	u	à	ò	Ñ	⋮	⋮	⋮	⋮
6	6		&	6	F	V	f	v	á	ó	á	⋮	⋮	⋮	⋮	⋮
7	7	BEL		'	7	G	W	g	w	ç	ü	ø	⋮	⋮	⋮	⋮
8	8	BS	CAN	(	8	H	X	h	x	é	ÿ	¿	⋮	⋮	⋮	⋮
9	9	HT	EM	)	9	I	Y	i	y	è	Ö	⋮	⋮	⋮	⋮	⋮
10	A	LF		*	:	J	Z	j	z	è	Ü	⋮	⋮	⋮	⋮	⋮
11	B	VT	ESC	+	:	K	[	k	{	í	ç	½	⋮	⋮	⋮	⋮
12	C	FF		.	<	L	\	l		í	É	¼	⋮	⋮	⋮	⋮
13	D	CR		-	=	M	]	m	}	í	ÿ	í	⋮	⋮	⋮	⋮
14	E	SO		.	>	N	^	n	~	Á	Pr	<<	⋮	⋮	⋮	⋮
15	F	SI		/	?	O	_	o	DEL	Á	f	>>	⋮	⋮	⋮	⋮

**Note:**

- Set 1 is the same one which 80H~9FH is switched to 00H~1FH and 95H is switched to NUL.

## Epson Character Set 2 (Multilingual) PC850

Dec.	0	16	32	48	64	80	96	112	128	144	160	176	192	208	224	240	
Hex.	0	1	2	3	4	5	6	7	8	9	A	B	C	D	E	F	
0	0	NUL	SP	0	•	P	'	p	Ç	É	á	⋮	⋮	⋮	⋮	⋮	
1	1		DC1	!	!	A	O	a	q	ü	æ	í	⋮	⋮	⋮	⋮	
2	2		DC2	"	2	B	R	b	r	é	Æ	ó	⋮	⋮	⋮	⋮	
3	3		DC3	#	3	C	S	c	s	á	ò	ú	⋮	⋮	⋮	⋮	
4	4		DC4	\$	4	D	T	d	t	á	ò	ñ	⋮	⋮	⋮	⋮	
5	5		§	%	5	E	U	e	u	à	ò	Ñ	Á	†	í	Ô	§
6	6		&	6	F	V	f	v	á	ú	á	Á	ã	í	µ	+	
7	7	BEL		'	7	G	W	g	w	ç	ü	ø	Á	Á	í	þ	.
8	8	BS	CAN	(	8	H	X	h	x	é	ÿ	¿	⋮	⋮	⋮	⋮	
9	9	HT	EM	)	9	I	Y	i	y	è	Ö	⋮	⋮	⋮	⋮	⋮	
10	A	LF		*	:	J	Z	j	z	è	Ü	⋮	⋮	⋮	⋮	⋮	
11	B	VT	ESC	+	:	K	[	k	{	í	ç	½	⋮	⋮	⋮	⋮	
12	C	FF		.	<	L	\	l		í	É	¼	⋮	⋮	⋮	⋮	
13	D	CR		-	=	M	]	m	}	í	ÿ	í	⋮	⋮	⋮	⋮	
14	E	SO		.	>	N	^	n	~	Á	x	<<	⋮	⋮	⋮	⋮	
15	F	SI		/	?	O	_	o	DEL	Á	f	>>	⋮	⋮	⋮	⋮	

## Epson Character Set 2 (Portugal) PC860

Dec.	0	16	32	48	64	80	96	112	128	144	160	176	192	208	224	240
Hex.	0	1	2	3	4	5	6	7	8	9	A	B	C	D	E	F
0	0	NUL	SP	0	•	P	'	p	Ç	É	á	⋮	⋮	⋮	⋮	⋮
1	1		DC1	!	!	A	O	a	q	ü	Á	í	⋮	⋮	⋮	⋮
2	2		DC2	"	2	B	R	b	r	é	É	ó	⋮	⋮	⋮	⋮
3	3		DC3	#	3	C	S	c	s	á	ò	ú	⋮	⋮	⋮	⋮
4	4		DC4	\$	4	D	T	d	t	á	ò	ñ	⋮	⋮	⋮	⋮
5	5		§	%	5	E	U	e	u	à	ò	Ñ	⋮	⋮	⋮	⋮
6	6		&	6	F	V	f	v	Á	Ü	á	⋮	⋮	⋮	⋮	⋮
7	7	BEL		'	7	G	W	g	w	ç	ü	ø	⋮	⋮	⋮	⋮
8	8	BS	CAN	(	8	H	X	h	x	é	ÿ	¿	⋮	⋮	⋮	⋮
9	9	HT	EM	)	9	I	Y	i	y	é	Ö	⋮	⋮	⋮	⋮	⋮
10	A	LF		*	:	J	Z	j	z	è	Ü	⋮	⋮	⋮	⋮	⋮
11	B	VT	ESC	+	:	K	[	k	{	í	ç	½	⋮	⋮	⋮	⋮
12	C	FF		.	<	L	\	l		í	É	¼	⋮	⋮	⋮	⋮
13	D	CR		-	=	M	]	m	}	í	ÿ	í	⋮	⋮	⋮	⋮
14	E	SO		.	>	N	^	n	~	Á	Pr	<<	⋮	⋮	⋮	⋮
15	F	SI		/	?	O	_	o	DEL	Á	ó	>>	⋮	⋮	⋮	⋮

**Note:**

- Set 1 is the same one which 80H~9FH is switched to 00H~1FH and 95H is switched to NUL.

Appendix



## Epson Character Set 2 (Canada-French) PC863

Dec.	Hex.															
	0	1	2	3	4	5	6	7	8	9	A	B	C	D	E	F
0	0	NUL	SP	0	•	P	'	p	Ç	É	Ì	⋮	⋮	⋮	α	»
1	1		DC1	!	1	A	O	a	q	û	É	·	⋮	⋮	β	±
2	2		DC2	*	2	B	R	b	r	é	É	ó	⋮	⋮	Γ	≥
3	3		DC3	#	3	C	S	c	s	á	ó	ú	⋮	⋮	π	≤
4	4		DC4	\$	4	D	T	d	t	Á	É	·	⋮	⋮	Σ	∫
5	5		§	%	5	E	U	e	u	à	Í	·	⋮	⋮	σ	∫
6	6			&	6	F	V	f	v	á	ú	3	⋮	⋮	μ	+
7	7	BEL		'	7	G	W	g	w	ç	ú	·	⋮	⋮	τ	-
8	8	BS	CAN	(	8	H	X	h	x	é	ó	í	⋮	⋮	φ	·
9	9	HT	EM	)	9	I	Y	i	y	è	Ó	·	⋮	⋮	θ	·
10	A	LF		*	:	J	Z	j	z	è	Ú	·	⋮	⋮	Ω	·
11	B	VT	ESC	+	:	K	{	k	{	í	ç	½	⋮	⋮	δ	√
12	C	FF		.	<	L	\	l	l	í	ç	¼	⋮	⋮	∞	°
13	D	CR		-	=	M	}	m	}	í	ç	¾	⋮	⋮	o	?
14	E	SO		.	>	N	^	n	-	Á	Ú	<<	⋮	⋮	ε	■
15	F	SI		/	?	O	_	o	·	§	/	>>	⋮	⋮	∅	SP

## Epson Character Set 2 (Norway) PC865

Dec.	Hex.															
	0	1	2	3	4	5	6	7	8	9	A	B	C	D	E	F
0	0	NUL	SP	0	•	P	'	p	Ç	É	á	⋮	⋮	⋮	α	»
1	1		DC1	!	1	A	Q	a	q	û	æ	í	⋮	⋮	β	±
2	2		DC2	*	2	B	R	b	r	é	Æ	ó	⋮	⋮	Γ	≥
3	3		DC3	#	3	C	S	c	s	á	ó	ú	⋮	⋮	π	≤
4	4		DC4	\$	4	D	T	d	t	á	ó	ñ	⋮	⋮	Σ	∫
5	5		§	%	5	E	U	e	u	à	ó	Ñ	⋮	⋮	σ	∫
6	6			&	6	F	V	f	v	á	ó	á	⋮	⋮	μ	+
7	7	BEL		'	7	G	W	g	w	ç	ú	ø	⋮	⋮	τ	-
8	8	BS	CAN	(	8	H	X	h	x	é	ý	í	⋮	⋮	φ	·
9	9	HT	EM	)	9	I	Y	i	y	è	Ó	·	⋮	⋮	θ	·
10	A	LF		*	:	J	Z	j	z	è	Ú	·	⋮	⋮	Ω	·
11	B	VT	ESC	+	:	K	{	k	{	í	ç	½	⋮	⋮	δ	√
12	C	FF		.	<	L	\	l	l	í	ç	¼	⋮	⋮	∞	°
13	D	CR		-	=	M	}	m	}	í	ç	¾	⋮	⋮	o	?
14	E	SO		.	>	N	^	n	-	Á	Ú	<<	⋮	⋮	ε	■
15	F	SI		/	?	O	_	o	·	Á	f	ç	⋮	⋮	∅	SP

**Note:**

- Set 1 is the same one which 80H~9FH is switched to 00H~1FH and 95H is switched to NUL.

## Epson Character Set 2 (Turkey) PC853

Dec.	Hex.																
	0	1	2	3	4	5	6	7	8	9	A	B	C	D	E	F	
0	0	NUL	SP	0	•	P	'	p	Ç	É	á	⋮	⋮	⋮	α	»	
1	1		DC1	!	1	A	O	a	q	û	æ	í	⋮	⋮	β	±	
2	2		DC2	*	2	B	R	b	r	é	Æ	ó	⋮	⋮	Γ	≥	
3	3		DC3	#	3	C	S	c	s	á	ó	ú	⋮	⋮	π	≤	
4	4		DC4	\$	4	D	T	d	t	á	ó	ñ	⋮	⋮	Σ	∫	
5	5		§	%	5	E	U	e	u	à	ó	Ñ	⋮	⋮	σ	∫	
6	6			&	6	F	V	f	v	á	ó	Ğ	⋮	⋮	μ	+	
7	7	BEL		'	7	G	W	g	w	ç	ú	ø	⋮	⋮	τ	-	
8	8	BS	CAN	(	8	H	X	h	x	é	ı	ı	⋮	⋮	φ	·	
9	9	HT	EM	)	9	I	Y	i	y	è	Ó	·	⋮	⋮	θ	·	
10	A	LF		*	:	J	Z	j	z	è	Ú	·	⋮	⋮	Ω	·	
11	B	VT	ESC	+	:	K	{	k	{	í	ç	½	⋮	⋮	δ	√	
12	C	FF		.	<	L	\	l	l	í	ç	¼	⋮	⋮	∞	°	
13	D	CR		-	=	M	}	m	}	ı	ı	ı	⋮	⋮	o	?	
14	E	SO		.	>	N	^	n	-	Á	Ş	<<	⋮	⋮	ε	■	
15	F	SI		/	?	O	_	o	·	DEL	Á	ş	>>	⋮	⋮	∅	SP

**Note:**

- Set 1 is the same one which 80H~9FH is switched to 00H~1FH and 95H is switched to NUL.

# Character Set Tables

## IBM Character Set 2 (USA)

Dec.	0	16	32	48	64	80	96	112	128	144	160	176	192	208	224	240	
Hex.	0	1	2	3	4	5	6	7	8	9	A	B	C	D	E	F	
0	0	NUL	SP	0	Ⓟ	P	·	p	Ç	É	á	⋮	⌈	⌋	α	■	
1	1	DC1	!	1	A	O	a	q	ü	æ	í	⋮	⌈	⌋	β	±	
2	2	DC2	"	2	B	R	b	r	é	Æ	ó	⋮	⌈	⌋	Γ	≥	
3	3	▼	#	3	C	S	c	s	à	ò	ú	⋮	⌈	⌋	π	≤	
4	4	♦	DC4	\$	4	D	T	d	t	ä	ö	ñ	⋮	⌈	⌋	Σ	∫
5	5	▲	§	%	5	E	U	e	u	ä	ö	Ñ	⋮	⌈	⌋	F	σ
6	6	▲	&	6	F	V	f	v	ä	ü	á	⋮	⌈	⌋	μ	÷	
7	7	BEL	'	7	G	W	g	w	ç	ù	ø	⋮	⌈	⌋	τ	-	
8	8	BS	CAN	(	8	H	X	h	x	é	ý	¿	⋮	⌈	⌋	φ	•
9	9	HT	)	9	I	Y	i	y	è	Ö	⋮	⌈	⌋	θ	•		
10	A	LF	*	:	J	Z	j	z	è	Ü	⋮	⌈	⌋	Ω	•		
11	B	VT	ESC	+	:	K	[	k	{	í	ç	½	⋮	⌈	⌋	δ	√
12	C	FF	.	<	L	\			í	£	¼	⋮	⌈	⌋	∞	•	
13	D	CR	-	=	M	]	m	}	í	¥	í	⋮	⌈	⌋	ø	z	
14	E	SO	.	>	N	^	n	~	Ä	Pt	<<	⋮	⌈	⌋	ε	■	
15	F	SI	/	?	O	_	o		À	f	>>	⋮	⌈	⌋	∩	SP	

**Note:**

- Set 1 is the same one which 03H~06H and 15H are switched to NUL, and 80H~9FH is switched to 00H~1FH.

## IBM All Character Chart (USA)

Dec.	0	16	32	48	64	80	96	112	128	144	160	176	192	208	224	240	
Hex.	0	1	2	3	4	5	6	7	8	9	A	B	C	D	E	F	
0	0	Ⓟ	▶	SP	0	Ⓟ	P	·	p	Ç	É	á	⋮	⌈	⌋	α	■
1	1	◀	!	1	A	Q	a	q	ü	æ	í	⋮	⌈	⌋	β	±	
2	2	•	↑	"	2	B	R	b	r	é	Æ	ó	⋮	⌈	⌋	Γ	≥
3	3	▼	!!	#	3	C	S	c	s	à	ò	ú	⋮	⌈	⌋	π	≤
4	4	♦	¶	\$	4	D	T	d	t	ä	ö	ñ	⋮	⌈	⌋	Σ	∫
5	5	▲	§	%	5	E	U	e	u	ä	ö	Ñ	⋮	⌈	⌋	F	σ
6	6	▲	-	&	6	F	V	f	v	ä	ü	á	⋮	⌈	⌋	μ	÷
7	7	•	↑	'	7	G	W	g	w	ç	ù	ø	⋮	⌈	⌋	τ	-
8	8	◻	↑	(	8	H	X	h	x	é	ý	¿	⋮	⌈	⌋	φ	•
9	9	◊	↓	)	9	I	Y	i	y	è	Ö	⋮	⌈	⌋	θ	•	
10	A	◻	→	*	:	J	Z	j	z	è	Ü	⋮	⌈	⌋	Ω	•	
11	B	♂	←	+	:	K	[	k	{	í	ç	½	⋮	⌈	⌋	δ	√
12	C	♀	↓	.	<	L	\			í	£	¼	⋮	⌈	⌋	∞	•
13	D	♂	←	-	=	M	]	m	}	í	¥	í	⋮	⌈	⌋	ø	z
14	E	♂	▲	.	>	N	^	n	~	Ä	Pt	<<	⋮	⌈	⌋	ε	■
15	F	♂	▼	/	?	O	_	o	ó	À	f	>>	⋮	⌈	⌋	∩	SP

## IBM Character Set 2 (Multilingual)

Dec.	0	16	32	48	64	80	96	112	128	144	160	176	192	208	224	240		
Hex.	0	1	2	3	4	5	6	7	8	9	A	B	C	D	E	F		
0	0	NUL	SP	0	Ⓟ	P	·	p	Ç	É	á	⋮	⌈	⌋	ø	-		
1	1	DC1	!	1	A	O	a	q	ü	æ	í	⋮	⌈	⌋	ø	±		
2	2	DC2	"	2	B	R	b	r	é	Æ	ó	⋮	⌈	⌋	È	◌		
3	3	▼	#	3	C	S	c	s	à	ò	ú	⋮	⌈	⌋	È	◌		
4	4	♦	DC4	\$	4	D	T	d	t	ä	ö	ñ	⋮	⌈	⌋	È	◌	
5	5	▲	§	%	5	E	U	e	u	ä	ö	Ñ	Á	⋮	⌈	⌋	È	◌
6	6	▲	&	6	F	V	f	v	ä	ü	á	⋮	⌈	⌋	Á	◌		
7	7	BEL	'	7	G	W	g	w	ç	ù	ø	Á	Á	⋮	⌈	⌋	◌	
8	8	BS	CAN	(	8	H	X	h	x	é	ý	¿	◌	⋮	⌈	⌋	◌	
9	9	HT	)	9	I	Y	i	y	è	Ö	⋮	⌈	⌋	◌	◌			
10	A	LF	*	:	J	Z	j	z	è	Ü	⋮	⌈	⌋	◌	◌			
11	B	VT	ESC	+	:	K	[	k	{	í	ç	½	⋮	⌈	⌋	◌	◌	
12	C	FF	.	<	L	\			í	£	¼	⋮	⌈	⌋	◌	◌		
13	D	CR	-	=	M	]	m	}	í	¥	í	⋮	⌈	⌋	◌	◌		
14	E	SO	.	>	N	^	n	~	Ä	x	<<	⋮	⌈	⌋	◌	◌		
15	F	SI	/	?	O	_	o		À	f	>>	⋮	⌈	⌋	◌	◌		

**Note:**

- Set 1 is the same one which 03H~06H and 15H are switched to NUL, and 80H~9FH is switched to 00H~1FH.

## IBM All Character Chart (Multilingual)

Dec.	0	16	32	48	64	80	96	112	128	144	160	176	192	208	224	240		
Hex.	0	1	2	3	4	5	6	7	8	9	A	B	C	D	E	F		
0	0	Ⓟ	▶	SP	0	Ⓟ	P	·	p	Ç	É	á	⋮	⌈	⌋	ø	-	
1	1	◀	!	1	A	Q	a	q	ü	æ	í	⋮	⌈	⌋	ø	±		
2	2	•	↑	"	2	B	R	b	r	é	Æ	ó	⋮	⌈	⌋	È	◌	
3	3	▼	!!	#	3	C	S	c	s	à	ò	ú	⋮	⌈	⌋	È	◌	
4	4	♦	¶	\$	4	D	T	d	t	ä	ö	ñ	⋮	⌈	⌋	È	◌	
5	5	▲	§	%	5	E	U	e	u	ä	ö	Ñ	Á	⋮	⌈	⌋	È	◌
6	6	▲	-	&	6	F	V	f	v	ä	ü	á	⋮	⌈	⌋	Á	◌	
7	7	•	↑	'	7	G	W	g	w	ç	ù	ø	Á	Á	⋮	⌈	⌋	◌
8	8	◻	↑	(	8	H	X	h	x	é	ý	¿	◌	⋮	⌈	⌋	◌	
9	9	◊	↓	)	9	I	Y	i	y	è	Ö	⋮	⌈	⌋	◌	◌		
10	A	◻	→	*	:	J	Z	j	z	è	Ü	⋮	⌈	⌋	◌	◌		
11	B	♂	←	+	:	K	[	k	{	í	ç	½	⋮	⌈	⌋	◌	◌	
12	C	♀	↓	.	<	L	\			í	£	¼	⋮	⌈	⌋	◌	◌	
13	D	♂	←	-	=	M	]	m	}	í	¥	í	⋮	⌈	⌋	◌	◌	
14	E	♂	▲	.	>	N	^	n	~	Ä	x	<<	⋮	⌈	⌋	◌	◌	
15	F	♂	▼	/	?	O	_	o	ó	À	f	>>	⋮	⌈	⌋	◌	◌	

Appendix

## IBM Character Set 2 (Portugal)

Dec.	0	16	32	48	64	80	96	112	128	144	160	176	192	208	224	240
Hex.	0	1	2	3	4	5	6	7	8	9	A	B	C	D	E	F
0	0	NUL	SP	0	Ⓟ	P	'	p	Ç	É	á	⋮	L	⏏	α	■
1	1		DC1	!	1	A	Q	a	q	û	À	í	⋮	⏏	β	±
2	2		DC2	"	2	B	R	b	r	é	Ê	ó	⋮	⏏	Γ	≥
3	3	▼		#	3	C	S	c	s	ã	ô	ú	⋮	⏏	κ	≤
4	4	*	DC4	\$	4	D	T	d	t	ä	õ	ñ	⋮	⏏	Σ	∫
5	5	▲	§	%	5	E	U	e	u	à	ò	ñ	⋮	⏏	σ	∫
6	6	▲		&	6	F	V	f	v	Á	Ú	ã	⋮	⏏	μ	+
7	7	BEL		'	7	G	W	g	w	ç	ü	ø	⋮	⏏	τ	*
8	8	BS	CAN	(	8	H	X	h	x	ê	ï	¿	⋮	⏏	Φ	.
9	9	HT		)	9	I	Y	i	y	ê	Ó	Ô	⋮	⏏	θ	•
10	A	LF		*	:	J	Z	j	z	è	Û	⋮	⏏	⏏	Ω	.
11	B	VT	ESC	+	:	K	[	k	{	í	ç	½	⋮	⏏	δ	√
12	C	FF		.	<	L	\	l		ó	£	¼	⋮	⏏	∞	°
13	D	CR		-	=	M	]	m	}	í	Û	¼	⋮	⏏	σ	²
14	E	SO		.	>	N	^	n	~	À	Û	<<	⋮	⏏	ε	■
15	F	SI		/	?	O	_	o		À	Ó	>>	⋮	⏏	∩	SP

**Note:**

- Set 1 is the same one which 03H~06H and 15H are switched to NUL, and 80H~9FH is switched to 00H~1FH.

## IBM All Character (Portugal)

Dec.	0	16	32	48	64	80	96	112	128	144	160	176	192	208	224	240
Hex.	0	1	2	3	4	5	6	7	8	9	A	B	C	D	E	F
0	0	ø	▶	SP	0	Ⓟ	P	'	p	Ç	É	á	⋮	L	⏏	α
1	1	◊	◀	!	1	A	Q	a	q	û	À	í	⋮	⏏	β	±
2	2	●	↕	"	2	B	R	b	r	é	Ê	ó	⋮	⏏	Γ	≥
3	3	▼		#	3	C	S	c	s	ã	ô	ú	⋮	⏏	κ	≤
4	4	*	¶	\$	4	D	T	d	t	ä	õ	ñ	⋮	⏏	Σ	∫
5	5	▲	§	%	5	E	U	e	u	à	ò	ñ	⋮	⏏	σ	∫
6	6	▲	-	&	6	F	V	f	v	Á	Ú	ã	⋮	⏏	μ	+
7	7	•	⏏	'	7	G	W	g	w	ç	ü	ø	⋮	⏏	τ	*
8	8	◻	↑	(	8	H	X	h	x	ê	ï	¿	⋮	⏏	Φ	.
9	9	◊	↓	)	9	I	Y	i	y	ê	Ó	Ô	⋮	⏏	θ	•
10	A	◻	→	*	:	J	Z	j	z	è	Û	⋮	⏏	⏏	Ω	.
11	B	◊	←	+	:	K	[	k	{	í	ç	½	⋮	⏏	δ	√
12	C	◊	⏏	.	<	L	\	l		ó	£	¼	⋮	⏏	∞	°
13	D	◊	↔	-	=	M	]	m	}	í	Û	¼	⋮	⏏	σ	²
14	E	◊	▲	.	>	N	^	n	~	À	Û	<<	⋮	⏏	ε	■
15	F	◊	▼	/	?	O	_	o	◊	À	Ó	>>	⋮	⏏	∩	SP

## IBM Character Set 2 (Canada-French)

Dec.	0	16	32	48	64	80	96	112	128	144	160	176	192	208	224	240
Hex.	0	1	2	3	4	5	6	7	8	9	A	B	C	D	E	F
0	0	NUL	SP	0	Ⓟ	P	'	p	Ç	É	í	⋮	L	⏏	α	■
1	1		DC1	!	1	A	Q	a	q	û	È	'	⋮	⏏	β	±
2	2		DC2	"	2	B	R	b	r	é	Ê	ó	⋮	⏏	Γ	≥
3	3	▼		#	3	C	S	c	s	ã	ô	ú	⋮	⏏	κ	≤
4	4	*	DC4	\$	4	D	T	d	t	Ä	É	'	⋮	⏏	Σ	∫
5	5	▲	§	%	5	E	U	e	u	à	ï	'	⋮	⏏	σ	∫
6	6	▲		&	6	F	V	f	v	ŕ	ó	3	⋮	⏏	μ	+
7	7	BEL		'	7	G	W	g	w	ç	ü	'	⋮	⏏	τ	*
8	8	BS	CAN	(	8	H	X	h	x	ê	ï	¿	⋮	⏏	Φ	.
9	9	HT		)	9	I	Y	i	y	ê	Ó	Ô	⋮	⏏	θ	•
10	A	LF		*	:	J	Z	j	z	è	Û	⋮	⏏	⏏	Ω	.
11	B	VT	ESC	+	:	K	[	k	{	í	ç	½	⋮	⏏	δ	√
12	C	FF		.	<	L	\	l		í	£	¼	⋮	⏏	∞	°
13	D	CR		-	=	M	]	m	}	í	Û	¼	⋮	⏏	σ	²
14	E	SO		.	>	N	^	n	~	À	Û	<<	⋮	⏏	ε	■
15	F	SI		/	?	O	_	o		À	Ó	>>	⋮	⏏	∩	SP

**Note:**

- Set 1 is the same one which 03H~06H and 15H are switched to NUL, and 80H~9FH is switched to 00H~1FH.

## IBM All Character (Canada-French)

Dec.	0	16	32	48	64	80	96	112	128	144	160	176	192	208	224	240
Hex.	0	1	2	3	4	5	6	7	8	9	A	B	C	D	E	F
0	0	ø	▶	SP	0	Ⓟ	P	'	p	Ç	É	í	⋮	L	⏏	α
1	1	◊	◀	!	1	A	Q	a	q	û	È	'	⋮	⏏	β	±
2	2	●	↕	"	2	B	R	b	r	é	Ê	ó	⋮	⏏	Γ	≥
3	3	▼		#	3	C	S	c	s	ã	ô	ú	⋮	⏏	κ	≤
4	4	*	¶	\$	4	D	T	d	t	Ä	É	'	⋮	⏏	Σ	∫
5	5	▲	§	%	5	E	U	e	u	à	ï	'	⋮	⏏	σ	∫
6	6	▲	-	&	6	F	V	f	v	ŕ	ó	3	⋮	⏏	μ	+
7	7	•	⏏	'	7	G	W	g	w	ç	ü	'	⋮	⏏	τ	*
8	8	◻	↑	(	8	H	X	h	x	ê	ï	¿	⋮	⏏	Φ	.
9	9	◊	↓	)	9	I	Y	i	y	ê	Ó	Ô	⋮	⏏	θ	•
10	A	◻	→	*	:	J	Z	j	z	è	Û	⋮	⏏	⏏	Ω	.
11	B	◊	←	+	:	K	[	k	{	í	ç	½	⋮	⏏	δ	√
12	C	◊	⏏	.	<	L	\	l		í	£	¼	⋮	⏏	∞	°
13	D	◊	↔	-	=	M	]	m	}	í	Û	¼	⋮	⏏	σ	²
14	E	◊	▲	.	>	N	^	n	~	À	Û	<<	⋮	⏏	ε	■
15	F	◊	▼	/	?	O	_	o	◊	À	Ó	>>	⋮	⏏	∩	SP

# Character Set Tables

## IBM Character Set 2 (Norway)

Dec.	0	16	32	48	64	80	96	112	128	144	160	176	192	208	224	240
Hex.	0	1	2	3	4	5	6	7	8	9	A	B	C	D	E	F
0	0	NUL	SP	0	ø	P	·	p	ç	É	á	⋮	L	ll	α	≡
1	1		DC1	!	1	A	Q	a	q	ü	æ	í	⋮	ll	β	±
2	2		DC2	"	2	B	R	b	r	é	Æ	ó	⋮	ll	Γ	≥
3	3	▼		#	3	C	S	c	s	á	ò	ú	⋮	ll	π	≤
4	4	•	DC4	\$	4	D	T	d	t	ä	ö	ñ	⋮	ll	Σ	∫
5	5	▲	§	%	5	E	U	e	u	à	ò	Ñ	⋮	ll	F	σ
6	6	▲		&	6	F	V	f	v	ä	ü	ä	⋮	ll	μ	÷
7	7	BEL		'	7	G	W	g	w	ç	ü	ç	⋮	ll	τ	-
8	8	BS	CAN	(	8	H	X	h	x	é	ý	¿	⋮	ll	Φ	•
9	9	HT		)	9	I	Y	i	y	è	Ö	⋮	ll	ll	θ	•
10	A	LF		*	:	J	Z	j	z	è	Ü	⋮	ll	ll	Ω	•
11	B	VT	ESC	+	:	K	[	k	{	í	ø	½	⋮	ll	δ	√
12	C	FF		.	<	L	\	l	l	í	É	¼	⋮	ll	∞	°
13	D	CR		-	=	M	]	m	}	l	Ø	i	⋮	ll	o	?
14	E	SO		.	>	N	^	n	˘	Ä	Œ	<<	⋮	ll	ε	■
15	F	SI		/	?	O	_	o	˘	Å	Œ	>>	⋮	ll	∅	SP

**Note:**

- Set 1 is the same one which 03H~06H and 15H are switched to NUL, and 80H~9FH is switched to 00H~1FH.

## IBM All Character (Norway)

Dec.	0	16	32	48	64	80	96	112	128	144	160	176	192	208	224	240	
Hex.	0	1	2	3	4	5	6	7	8	9	A	B	C	D	E	F	
0	0	ø	▶	SP	0	ø	P	·	p	ç	É	á	⋮	L	ll	α	≡
1	1	◀	!	1	A	Q	a	q	ü	æ	í	⋮	ll	ll	β	±	
2	2	•	↓	"	2	B	R	b	r	é	Æ	ó	⋮	ll	Γ	≥	
3	3	▼	!!	#	3	C	S	c	s	á	ò	ú	⋮	ll	π	≤	
4	4	•	¶	\$	4	D	T	d	t	ä	ö	ñ	⋮	ll	Σ	∫	
5	5	▲	§	%	5	E	U	e	u	à	ò	Ñ	⋮	ll	F	σ	
6	6	▲	-	&	6	F	V	f	v	ä	ü	ä	⋮	ll	μ	÷	
7	7	•	↓	'	7	G	W	g	w	ç	ü	ç	⋮	ll	τ	-	
8	8	◻	↑	(	8	H	X	h	x	é	ý	¿	⋮	ll	Φ	•	
9	9	◻	↓	)	9	I	Y	i	y	è	Ö	⋮	ll	ll	θ	•	
10	A	◻	→	*	:	J	Z	j	z	è	Ü	⋮	ll	ll	Ω	•	
11	B	◻	←	+	:	K	[	k	{	í	ø	½	⋮	ll	δ	√	
12	C	◻	↓	.	<	L	\	l	l	í	É	¼	⋮	ll	∞	°	
13	D	◻	↔	-	=	M	]	m	}	l	Ø	i	⋮	ll	o	?	
14	E	◻	▲	.	>	N	˘	n	˘	Ä	Œ	<<	⋮	ll	ε	■	
15	F	◻	▼	/	?	O	_	o	˘	Å	Œ	>>	⋮	ll	∅	DEL	

## IBM Character Set 2 (Turkey)

Dec.	0	16	32	48	64	80	96	112	128	144	160	176	192	208	224	240
Hex.	0	1	2	3	4	5	6	7	8	9	A	B	C	D	E	F
0	0	NUL	SP	0	ø	P	·	p	ç	É	á	⋮	L	ll	α	≡
1	1		DC1	!	1	A	Q	a	q	ü	æ	í	⋮	ll	β	±
2	2		DC2	"	2	B	R	b	r	é	Æ	ó	⋮	ll	Γ	≥
3	3	▼		#	3	C	S	c	s	á	ò	ú	⋮	ll	π	≤
4	4	•	DC4	\$	4	D	T	d	t	ä	ö	ñ	⋮	ll	Σ	∫
5	5	▲	§	%	5	E	U	e	u	à	ò	Ñ	⋮	ll	F	σ
6	6	▲		&	6	F	V	f	v	ä	ü	ä	⋮	ll	μ	÷
7	7	BEL		'	7	G	W	g	w	ç	ü	ç	⋮	ll	τ	-
8	8	BS	CAN	(	8	H	X	h	x	é	ı	¿	⋮	ll	Φ	•
9	9	HT		)	9	I	Y	i	y	è	Ö	⋮	ll	ll	θ	•
10	A	LF		*	:	J	Z	j	z	è	Ü	⋮	ll	ll	Ω	•
11	B	VT	ESC	+	:	K	[	k	{	í	ç	½	⋮	ll	δ	√
12	C	FF		.	<	L	\	l	l	í	É	¼	⋮	ll	∞	°
13	D	CR		-	=	M	]	m	}	l	ı	i	⋮	ll	o	?
14	E	SO		.	>	N	˘	n	˘	Ä	Œ	<<	⋮	ll	ε	■
15	F	SI		/	?	O	_	o	˘	Å	Œ	>>	⋮	ll	∅	SP

**Note:**

- Set 1 is the same one which 03H~06H and 15H are switched to NUL, and 80H~9FH is switched to 00H~1FH.

## IBM All Character (Turkey)

Dec.	0	16	32	48	64	80	96	112	128	144	160	176	192	208	224	240	
Hex.	0	1	2	3	4	5	6	7	8	9	A	B	C	D	E	F	
0	0	ø	▶	SP	0	ø	P	·	p	ç	É	á	⋮	L	ll	α	≡
1	1	◀	!	1	A	Q	a	q	ü	æ	í	⋮	ll	ll	β	±	
2	2	•	↓	"	2	B	R	b	r	é	Æ	ó	⋮	ll	Γ	≥	
3	3	▼	!!	#	3	C	S	c	s	á	ò	ú	⋮	ll	π	≤	
4	4	•	¶	\$	4	D	T	d	t	ä	ö	ñ	⋮	ll	Σ	∫	
5	5	▲	§	%	5	E	U	e	u	à	ò	Ñ	⋮	ll	F	σ	
6	6	▲	-	&	6	F	V	f	v	ä	ü	ä	⋮	ll	μ	÷	
7	7	•	↓	'	7	G	W	g	w	ç	ü	ç	⋮	ll	τ	-	
8	8	◻	↑	(	8	H	X	h	x	é	ı	¿	⋮	ll	Φ	•	
9	9	◻	↓	)	9	I	Y	i	y	è	Ö	⋮	ll	ll	θ	•	
10	A	◻	→	*	:	J	Z	j	z	è	Ü	⋮	ll	ll	Ω	•	
11	B	◻	←	+	:	K	[	k	{	í	ç	½	⋮	ll	δ	√	
12	C	◻	↓	.	<	L	\	l	l	í	É	¼	⋮	ll	∞	°	
13	D	◻	↔	-	=	M	]	m	}	l	ı	i	⋮	ll	o	?	
14	E	◻	▲	.	>	N	˘	n	˘	Ä	Œ	<<	⋮	ll	ε	■	
15	F	◻	▼	/	?	O	_	o	˘	Å	Œ	>>	⋮	ll	∅	SP	

Appendix

## International Character Set

	n	35o 23H	36o 24H	64o 40H	91o 5BH	92o 5CH	93o 5DH	94o 5EH	96o 60H	123o 7BH	124o 7CH	125o 7DH	126o 7EH	155o 9BH	157o 9DH
USA	0	#	\$	@	[	\	]	^	'	{		}	~	¢	¥
FRANCE	1	#	\$	à	°	ç	§	^	'	é	ù	è	~	¢	¥
GERMANY	2	#	\$	§	Ä	Ö	Ü	^	'	ä	ö	ü	ß	¢	¥
U.K.	3	£	\$	@	[	\	]	^	'	{		}	~	¢	¥
DENMARK I	4	#	\$	@	Æ	Ø	Å	^	'	æ	ø	å	~	ø	Ø
SWEDEN	5	#	□	É	Ä	Ö	Å	Û	é	ä	ö	å	ü	¢	¥
ITALY	6	#	\$	@	°	\	é	^	ù	à	ò	è	ì	¢	¥
SPAIN I	7	Pl	\$	@	ì	Ñ	¿	^	'	ñ	ó	ú	~	¢	¥
JAPAN	8	#	\$	@	[	¥	]	^	'	{		}	~	¢	¥
NORWAY	9	#	□	É	Æ	Ø	Å	Û	é	æ	ø	å	ü	ø	Ø
DENMARK II	10	#	\$	É	Æ	Ø	Å	Û	é	æ	ø	å	ü	ø	Ø
SPAIN II	11	#	\$	á	ì	Ñ	¿	é	^	í	ñ	ó	ú	¢	¥
LATIN AMERICA	12	#	\$	á	ì	Ñ	¿	é	ü	í	ñ	ó	ú	¢	¥
KOREA	13	#	\$	@	[	₩	]	^	'	{		}	~	¢	¥
LEGAL	64	#	\$	§	°	'	"	¶	'	©	®	†	™	¢	¥

\*1

\*2

**Note:**

- \*1 These characters can be changed only in the Epson LQ-1170 mode. In the IBM Proprinter XL24E mode, International Character Set is set to USA and it cannot be changed.
- \*2 These characters are effective in both Graphic Character Set 2 of the Epson LQ-1170 and IBM Proprinter XL24E modes.

# Glossary

**ASCII:**

"ASCII" is an acronym for "American Standard Code for Information Interchange". In ASCII, each character has a unique code.

**BASIC:**

BASIC is a commonly used microcomputer programming language.

**Baud (baud rate):**

Baud is a unit of data transmission speed between computer devices.

Can be, but not necessarily, equal to bits per second.

**Bidirectional printing:**

Processing speed is increased by bidirectional printing. That is, the printer prints right-to-left as well as in the normal left-to-right manner.

**Binary:**

Binary is a numbering system using the two digits of zero (0) and one (1).

**Bit:**

Bit is an abbreviation for "binary digit (0-1)", and is the smallest unit of information used by a printer or computer.

**Bit-image graphics:**

Graphics which are created through a series of dots printed in vertical columns.

**Buffer:**

Buffer is an area of memory which stores data temporarily.

**Byte:**

Byte is the unit of information used by a printer or computer. One byte is equivalent to eight (8) bits.

**Character set:**

Character set is the set of characters, numbers, and symbols available for printing.

**Code page:**

The computer system stores characters and numbers as a numerical data. The Code page is a table which is used to change them into the numerical data.

**Control codes:**

Control codes are commands from the computer to the printer that are non-printable characters. They are used to control printer functions.

**cpi:**

"cpi" is an abbreviation for "characters per inch", and means the maximum number of characters printed in one horizontal inch.

**cpl:**

"cpl" is an abbreviation for "characters per line", and means the maximum number of characters printed on one line.

**cps:**

"cps" is an abbreviation for "characters per second", and means the maximum number of characters printed in one second.

**CR (Carriage Return):**

"CR" is a control code that returns the printhead to the left margin.

**Decimal (Dec.):**

Decimal is a numbering system composed of 10 digits 0, 1, 2, 3, 4, 5, 6, 7, 8 and 9.

**Default:**

Default has two meanings: one indicates the previously set condition or settings executed when the power is turned on, reset or initialized; and the other indicates the original settings when shipped from the factory.

**Dots per inch (DPI):**

A measure of resolution used for monitors and printers.

**Download character:**

Download character is a character which the user can design.

**Draft:**

Draft is one of three print qualities available on this printer. DRAFT mode uses a minimum number of dots per character to maximize printing speed.

**Emulation:**

Emulation means to operate like another printer. KX-P3626 can emulate the Epson LQ-1170 or the IBM Proprinter XL24E.

**Escape (ESC) sequence:**

"ESC" is a control code that begins most printer commands. The characters which follow the "ESC" are interpreted as the command, rather than characters to print. "ESC" is also used to refer to the corresponding key on your keyboard used to back out of the current screen while viewing the Setup Disk.

**ESC/P2:**

An expanded level of commands for 24 and 48 pin dot matrix printers.

**Fanfold paper:**

Fanfold paper has regularly spaced sprocket holes on the left and right sides and pages are separated by a perforation between each sheet. May also be known as computer paper or tractor paper.

**FF (Form Feed):**

"FF" is a control code that advances the paper one page.

**Font:**

Font is a style and size of type designated by a family name.

**Graphics:**

Groups of dots or characters that are used to create images, as opposed to text and numbers.

**Graphics mode:**

A special mode of print in which only raster graphics printing is possible.

**Hexadecimal:**

Hexadecimal is a numbering system using the 16 digits, 0, 1, 2, 3, 4, 5, 6, 7, 8, 9, A, B, C, D, E and F.

**Initialization:**

Initialization means to reset the printer to the initial start up condition.

**Interface:**

Interface is the connection between the two separate systems, such as the computer and the printer. A parallel interface transfers data one character or code at a time, and a serial interface transfers data one bit at a time.

**International Character Set:**

A set of characters defined by each country.

**I/O:**

"I/O" is the symbolic notation for "Input/Output".

**Italics:**

A font style in which character slants to the right. Used for emphasis, this is sometimes called oblique.

**Letter Quality (LQ):**

LQ is one of three print qualities available on this printer. LQ mode increases the number of dots per character to improve the print quality but decreases the print speed.

**LF (Line Feed):**

"LF" is a control code that advances the paper one line.

**LSB:**

"LSB" is an acronym for "Least Significant Bit", and means the rightmost position in a binary number.

**Margin:**

The area between the edge of the paper and the first or last print position; left, right, top or bottom margin.

**MSB:**

"MSB" is an acronym for "Most Significant Bit", and means the leftmost position in a binary number.

**OFF LINE:**

OFF LINE is the condition in which the printer can not communicate with the computer.

**ON LINE:**

ON LINE is the condition in which the printer can communicate with the computer.

**Overline printing:**

Overline printing produces a continuous line above the characters, using the first pin of the printhead.

**Parallel interface:**

Transmitting data one byte (8 bits) at a time from computer to printer.

**Parity:**

Parity is a method for a computer and printer to check the accuracy of data transfer.

**Perforation:**

Perforation indicates the tear position on the fanfold paper. ( P. 61)

**Pitch:**

Pitch is the number of characters which will print in one inch. Pitch is equivalent to characters per inch (cpi).

**Point size:**

A measure of character height used in typesetting. A point= $\frac{1}{72}$  of an inch.

**Printable area:**

The area of a page where the print quality is assured.

**Printer drivers:**

Most of today's off the shelf software programs use printer drivers to control printer functions. These drivers contain the software codes your software program uses to access printer features. With the printer driver installed, you will seldom need to know any of the KX-P3626 commands.

**Printing area:**

The area of the page within the margins, where printing actually occurs: The printing area is equal to or less than the printable area.

**Proportional spacing (PS):**

Proportional spacing is a printing method of adjusting the character space in which a character is printed. A "w" will take up more space than an "i".

**Protocol:**

Protocol is the set of rules permitting communication between a computer and printer when a serial interface (RS-232C) is used. It covers polarity, baud rate, parity, data length, start bit and stop bit.

**RAM:**

RAM is an acronym for "Random Access Memory". It is the part of the printer's memory in which data is stored, control codes or download characters are to be printed. RAM is cleared when the printer is turned off.

**R.D.T.:**

R.D.T. is the value of the remaining buffer capacity (R.B.C.) to resume data transfer from the computer after the data transfer is suspended by R.B.C. control.

**ROM:**

ROM is an acronym for "Read Only Memory". It is the part of the printer's memory in which predefined characters and operating information for the printer are stored. ROM is not cleared when the printer is turned off.

**Scalable fonts:**

The user can alter the point size of a selected font to make the font larger or smaller.

**S.D.T.:**

Serial Interface uses 1K byte Serial Buffer. S.D.T. is the value of the remaining buffer capacity to suspend data transfer from the computer.

**Self test:**

Self test is a method for testing the operation of the printer. ( P. 25)

**Serial interface:**

Transmitting data one bit at a time from computer to printer.

**Shielded cable:**

Shielded cable is a cable wrapped with a special metal around its wires. This guards against radio interference.

**Skip perforation:**

Skip perforation means nothing is printed in a specified area before and after the page perforation.

**String concatenation:**

This is the joining of two or more bytes of data into a single command.

**Style:**

A font attribute which slightly changes the appearance of the character. (ie: In Italics the character is printed on a slant.)

**Super Letter Quality (SLQ):**

SLQ is one of three print qualities available on this printer. SLQ mode uses a maximum number of dots per character to improve the print quality more than LQ mode but decreases the printing speed less than LQ mode.

**Super Quiet mode:**

SUPER QUIET mode reduces printing noise for a more comfortable work environment. It also reduces print speed.

**Top of Form:**

Top of Form is the first line position on the paper. ( P. 43).

**Typeface:**

All characters of a single, unified design at any size and rotation. Example: Roman, Prestige, etc.

**Unidirectional printing:**

The printer prints left-to-right only. Printing speed is slow compared with bidirectional printing. This print method permits better vertical alignment.

**Windows:**

An operating environment which lies between the operating system (DOS) and an application, that controls the system devices.



# Index

## A

ACK (Acknowledge) . . . . . 62, 63  
Alternate Graphics Mode (AGM) . . . . . 30  
AUTO FEED XT (AFXT) . . . . . 62, 63  
Automatic Carriage Return (AUTO CR) . . . . . 30  
Automatic Line Feed (AUTO LF) . . . . . 30, 47, 48  
Automatic paper loading (AUTO LOADING) . . . . . 30

## B

Bidirectional printing (BI DIRECTION) . . . . . 29  
Bold PS . . . . . 28, 40  
Bottom feeding . . . . . 19  
Bottom margin . . . . . 28  
Buffer . . . . . 57  
Buffer clear . . . . . 57  
BUSY signal . . . . . 62, 63  
Buzzer . . . . . 30

## C

Cable . . . . . 11, 62  
Cable connection . . . . . 11  
Centering (CTR PRINTHEAD) . . . . . 28  
Character sets . . . . . 58, 64~69  
    Epson LQ-1170 mode . . . . . 64, 65  
    IBM Proprinter XL24E mode . . . . . 66~68  
    International . . . . . 69  
Characters per inch (cpi) . . . . . 4, 28, 58  
Characters per line (cpl) . . . . . 58  
Character per second (cps) . . . . . 58  
Clear Buffer Function . . . . . 57  
Code page . . . . . 29  
Country selection . . . . . 29  
Courier . . . . . 28, 40  
Cover open sensor . . . . . 9, 59  
Cut Sheet Feeder option . . . . . 31, 47, 48, 56, 75  
Cut Sheet Feeder mode  
    (CSF MODE) . . . . . 30, 47, 48, 56

## D

Data length . . . . . 31, 50  
DATA1-DATA8 signal . . . . . 62, 63  
Default setting . . . . . 28~31, 38, 39, 51  
Dot configuration . . . . . 58  
Double high printing . . . . . 29  
Double strike printing . . . . . 29  
Double wide printing . . . . . 29  
Download buffer . . . . . 30  
Draft . . . . . 4, 28, 58

## E

Elite . . . . . 4, 58  
Emulation . . . . . 4, 28, 47, 48, 58  
    Epson LQ-1170 mode . . . . . 4, 28, 48, 58  
    IBM Proprinter XL24E mode . . . . . 4, 28, 48, 58  
Enhancement menu . . . . . 29  
Envelope . . . . . 23~24, 60, 61  
ERROR signal . . . . . 62, 63

## F

Factory setting . . . . . 28~31, 38, 39, 51  
Fanfold paper . . . . . 16~22, 60, 61  
FF switch . . . . . 9, 42  
FG (FRAME GROUND) signal . . . . . 62, 63  
Font . . . . . 4, 28, 40, 58  
Form feed . . . . . 42  
Frame ground terminal . . . . . 10, 11  
Friction . . . . . 23  
Front panel switches . . . . . 9

## G

Graphic direction . . . . . 29, 47, 48

## H

Head gap lever . . . . . 10  
Head service life . . . . . 59  
Hex dump . . . . . 57

## I

Initialization . . . . . 57  
Interfacing . . . . . 62, 63  
International Character set . . . . . 69  
Italics . . . . . 29

## L

Left margin . . . . . 28  
Letter Quality (LQ) . . . . . 4, 58  
LF switch . . . . . 9, 42  
Line feed . . . . . 42  
Lines per inch (lpi) . . . . . 28  
LOAD/PARK switch . . . . . 9, 45

## M

Maintenance	55
Micro line feed	42
Micron	4, 58

## O

ON LINE indicator light	9
ON LINE switch	9
Operating environment	5, 59
Outline printing	29
Overheat detector	59
Overload detector	59

## P

Page format	28
Page length	28
Paper feed selector	10, 16, 19, 23
Paper feeding	15~24
Friction mode	23, 24
Push tractor mode	16~22
Paper out detector	30, 46, 59
Paper parking	45
Paper specifications	60, 61
Paper supports	17, 20
Paper thickness	60
Parallel interface connector	11, 62
Parts of the printer	9, 10
Pica	4, 58
Pitch	28
PITCH switch	9, 40
Platen knob	6, 7, 9
PO (PAPER OUT) signal	62, 63
POWER/PAPER OUT indicator light	9
Power requirement	58
Power switch	9, 11
Prestige	28, 40
PRIME signal	62, 63
Print direction	29
Print setting	34
Print speed	4, 58
Print style	28
Print width	29
Printer driver	26, 27
Printhead	10, 13
Printing area	61
Proportional Spacing (PS)	72
Protective paper	7
Pull tractor	19~22
Push tractor	16~18

## R

Rear feeding	16~18
Reverse line feed (REVERSE LF/PULL)	30
Reverse micro line feed	42, 43
Ribbon cassette	6, 12~14
Right margin	28
Roman	4, 28, 40

## S

Sans Serif	4, 28, 40
Script	4, 28, 40
Self test	25
Serial interface	4, 31, 34, 38, 50, 58
Setup Disk	4, 6, 27, 28~39, 52~54
Command Reference program	52~54
Initial Setup program	28~39
Printer driver	26, 27
SG (SIGNAL GROUND) signal	62, 63
Shadow printing	29
Single sheet	23, 24, 60, 61
SLCT IN (SELECT IN) signal	62, 63
SLCT (SELECT) signal	62, 63
Smoked plastic cover	9
Specifications	58~61
STB (STROBE) signal	62, 63
Super Letter Quality (SLQ)	4, 58
SUPER QUIET indicator light	9
Super Quiet mode	41

## T

Tear Off	44
TEAR OFF switch	9, 44
Text direction	29
Top margin	28
Top of form (TOF) set	43
Tractor	10, 17
Tractor clamping lever	17
Troubleshooting	55, 56
TTL (Transistor-Transistor-Logic)	62

## U

Unidirectional printing (UNI)	29
Unpacking	6~8

## W

Windows printer driver	26
------------------------	----

## Z

Zero font	29
-----------	----

# Options and Supplies

---

KX-PS13	RS-232C/Current Loop Serial Interface Board (19.2 K Bps)
KX-PS14	RS-232C/Serial Interface Board (9600 Bps)
KX-P38	Cut Sheet Feeder (Single Bin)
KX-P170	Ribbon Cassette (Black)

## **FOR USERS IN CONTINENTAL UNITED STATES ONLY**

### **TECHNICAL SUPPORT CALLS**

If you have read this manual and tried the troubleshooting procedures and you are still having difficulty, please contact the store from which the unit was purchased.

You may also call the technical support telephone number which is operational during east coast business hours (9:00 AM to 7:00 PM).

For technical support, to order options and supplies or for the nearest authorized service center, please call 1-800-222-0584.

---

**Panasonic Communications & Systems Company,**  
**Computer Products Division**  
**Division of Matsushita Electric Corporation of America**  
Two Panasonic Way, Secaucus, New Jersey 07094

**Panasonic Sales Company**  
**Division of Matsushita Electric of Puerto Rico, Inc.**  
San Gabriel Industrial Park, 65th Infantry Avenue KM. 9.5  
Carolina, Puerto Rico 00630

---

**Matsushita Electric of Canada Limited**  
5770 Ambler Drive, Mississauga, Ontario, L4W 2T3

---

**Matsushita Electric Industrial Co., Ltd.**  
Central P.O. Box 288, Osaka 530-91, Japan

---